

Air conditioner

Installation manual

AC***DNND CG

- Thank you for purchasing this Samsung air conditioner.
- Before operating this unit, please read this manual carefully and retain it for future reference.

Contents

Safety Information	3
Safety Information	3
Installation Procedure	8
Installation Procedure	8
Step 1 Checking and preparing accessories	8
Step 2 Choosing the installation location	8
Step 3 Optional: Insulating the body of the indoor unit	11
Step 4 Installing the indoor unit	12
Step 5 Purging inert gas from the indoor unit	13
Step 6 Cutting and flaring the pipes	13
Step 7 Connecting the assembly pipes to the refrigerant pipes	14
Step 8 Performing the gas leak test	15
Step 9 Insulating the refrigerant pipes	15
Step 10 Installing the drain hose and drainpipe	16
Step 11 Performing the drainage test	19
Step 12 Connecting the power and communication cables	20
Step 13 Optional : Setting the Emergency Temperature Output (ETO) function	22
Step 14 Optional : LED Display indicator specifications when checking Wi-Fi Easy Setup and Wi-Fi status	24
Step 15 Setting the indoor unit addresses and the installation options	26
Appendix	40
Troubleshooting	40

Safety Information

California Proposition 65 Warning (US)

⚠ WARNING: Cancer and Reproductive Harm - www.P65Warnings.ca.gov.

IMPORTANT – This product has been designed and manufactured to meet ENERGY STAR criteria for energy efficiency when matched with appropriate coil components. However, proper refrigerant charge and proper air flow are critical to achieve rated capacity and efficiency. Installation of this product should follow the manufacturer's refrigerant charging and air flow instructions. Failure to confirm proper charge and airflow may reduce energy efficiency and shorten equipment life.

⚠ WARNING



- Hazards or unsafe practices that may result in severe personal injury or death.





⚠ CAUTION

- Hazards or unsafe practices that may result in minor personal injury or property damage.
- Carefully follow the precautions listed below because they are essential to guarantee the safety of the equipment.

⚠ WARNING

- Always disconnect the air conditioner from the power supply before servicing it or accessing its internal components.
- Verify that installation and testing operations are performed by qualified personnel.
- Verify that the air conditioner is not installed in an easily accessible area.

Symbol	Meaning
	Flammable gas
	Flammable materials

	Refrigerant safety group
	Read operating manual
	Refer to operating manual
	Read service manual

⚠ WARNING

The installation and testing of this appliance must be performed by a qualified technician.

- The instructions in this manual are not intended as a substitute for proper training or adequate experience in the safe installation of the appliance.

Always install the air conditioner in compliance with current local, state, and federal safety standards.

- Do not use means to accelerate the defrost operation or to clean, other than those recommended by Samsung.
- Do not pierce or burn.
- Be aware that refrigerants may not contain an odor.

General information

⚠ WARNING

- Carefully read the content of this manual before installing the air conditioner and store the manual in a safe place to be able to use it as a reference after installation.
- For maximum safety, installers should always carefully read the following warnings.
- Store the operation and installation manual in a safe location and remember to hand it over to the new owner if the air conditioner is sold or transferred.
- This manual explains how to install an indoor unit with a split system with two Samsung units. The use of other types of units with different control systems may damage the units and invalidate the warranty. The manufacturer shall not be responsible for damages arising from the use of non-compliant units.

Safety Information

- The manufacturer shall not be responsible for damage originating from unauthorized changes or the improper connection of electricity and requirements outlined in the "Operating limits" table, included in the manual, shall immediately invalidate the warranty.
- All pipe work including piping material, pipe routing, and installation shall include protection from physical damage in operation and service and comply with national and local codes and standards, such as ASHRAE 15, ASHRAE 15.2, IAPMO Uniform Mechanical Code, ICC International Mechanical Code, or CSA B52. Any field joints shall be accessible for inspection before being covered or enclosed.
- The air conditioner should be used only for the applications for which it has been designed: the indoor unit is not suitable to be installed in areas used for laundry.
- Do not use the units if damaged. If problems occur, switch the unit off and disconnect it from the power supply.
- To prevent electric shocks, fires or injuries, always stop the unit, disable the protection switch and contact Samsung's technical support if the unit produces smoke, if the power cable is hot or damaged or if the unit is very noisy.
- Always remember to inspect the unit, electric connections, refrigerant tubes and protections regularly. These operations should be performed by qualified personnel only.
- The unit contains moving parts, which should always be kept out of the reach of children.
- Do not attempt to repair, move, alter or reinstall the unit. If performed by unauthorized personnel, these operations may cause electric shocks or fires.
- Do not place containers with liquids or other objects on the unit.
- The air conditioner contains a refrigerant that has to be disposed of as special waste. At the end of its life cycle, the air conditioner must be disposed of in authorized centers or returned to the retailer so that it can be disposed of correctly and safely.
- Wear protective equipment (such as safety gloves, goggles, and headgear) during installation and maintenance work. Installation/repair technicians may be injured if improper protective equipment is worn.
- This unit is a partial unit air conditioner, complying with partial unit requirements of this International Standard, and must only be connected to other units that have been confirmed as complying with corresponding partial unit requirements of this International Standard.
- This appliance is not intended for use by persons (including children) with reduced physical, sensory, or mental capabilities, or lack of experience and knowledge unless they have been given supervision

or instruction concerning the use of the appliance by a person responsible for their safety. Children should be supervised to ensure that they do not play with the appliance.

Installing the unit

WARNING

IMPORTANT: When installing the unit, always remember to connect first the refrigerant tubes, and then the electrical lines.

- Always disassemble the electric lines before the refrigerant tubes.
- Upon receipt, inspect the product to verify that it has not been damaged during transport. If the product appears damaged, DO NOT INSTALL it, and immediately report the damage to the carrier or retailer (if the installer or the authorized technician has collected the material from the retailer.)
- After completing the installation, always carry out a functional test and provide instructions on how to operate the air conditioner to the user.
- Do not use the air conditioner in environments with hazardous substances or close to equipment that releases free flames to avoid the occurrence of fires, explosions or injuries.
- Do not install the product on a ship or a vehicle (such as a campervan). Salt, vibration or other environmental factors may cause the product to malfunction, electric shock or fire.
- Excessive indoor humidity or clogged condensate drain lines may cause water to drip from indoor units. Do not install the indoor unit where dripping could result in damage to property, such as over electronic equipment or other sensitive instruments.
- Our units must be installed in compliance with the space specifications presented in the installation manual to ensure accessibility from both sides and allow repairs or maintenance operations to be carried out. The unit's components must be accessible and easy to disassemble without endangering people and objects.
- For this reason, where it is not observed as indicated in the Installation Manual, the cost necessary to reach and repair the unit (safely as required by local regulations) with slings, trucks, scaffolding or any other means of elevation won't be considered in warranty and charged to end user.
- If any gas or impurities, except R-32 refrigerant, come into the refrigerant pipe, a serious problem may occur and it may cause injury. Use the supplied accessories, specified components and tools for the installation.

- Do not use the pipe and the installation product used for the R-22, R-410A refrigerant.
- Failure to use the specified components can cause the product to fall, water leakage, electrical shock, and fire. (The pipe and flare components used for R-22, R-410A refrigerant must not be used)
- Excessive indoor humidity or clogged condensate drain lines may cause water to drip from indoor units. Do not install the indoor unit where dripping could result in property damage, such as over electronic equipment or other sensitive instruments.

Power supply line, fuse or circuit breaker

WARNING

- Always make sure that the power supply is compliant with current safety standards. Always install the air conditioner in compliance with current local safety standards.
- Always verify that a suitable grounding connection is available.
- Verify that the voltage and frequency of the power supply comply with the specifications and that the installed power is sufficient to ensure the operation of any other domestic appliance connected to the same electric lines.
- Always verify that the cut-off and protection switches are suitable dimensioned.
- Verify that the air conditioner is connected to the power supply following the instructions provided in the wiring diagram included in the manual.
- Always verify that electric connections (cable entry, section of leads, protections...) are compliant with the electric specifications and with the instructions provided in the wiring scheme. Always verify that all connections comply with the standards applicable to the installation of air conditioners.
- Devices disconnected from the power supply should be completely disconnected in the condition of overvoltage category.

CAUTION

Make sure that you ground the cables.

- Do not connect the ground wire to the gas pipe, water pipe, lightning rod, or telephone wire. If the grounding is not complete, electric shock or fire may occur.

Install the circuit breaker.

- If the circuit breaker is not installed, electric shock or fire may occur.

Make sure that the condensed water dripping from the drain hose runs out properly and safely.

Install the power cable and communication cable of the indoor and outdoor unit at least 3.3ft (1m) away from the electric appliance.

Install the indoor unit away from a lighting apparatus using the ballast.

- If you use the wireless remote control, reception error may occur due to the ballast of the lighting apparatus.
- If the supply cord is damaged, it must be replaced by the manufacturer, its service agent or similarly qualified persons to avoid a hazard.

Do not use the indoor unit for the preservation of food items, plants, equipment, and artwork. This may cause deterioration of their quality.

Do not install the indoor unit if it has any drainage problems.

Precautions for using R-32 refrigerant

General

- This product is pre-charged with mildly flammable gas classified as A2L by ASHRAE. The following precautions and instruction manuals must be followed during installation, operation, servicing and decommissioning of the product.
- The appliance shall be stored in a room without continuously operating ignition sources, like open flames, a gas appliance, or an electric heater.
- All national and local regulations shall be observed at all times.
- All pipe work including piping material, pipe routing and installation shall include protection from physical damage in operation and service, and comply national and local codes and standards, such as ASHRAE 15, ASHRAE 15.2, IAPMO Uniform Mechanical Code, ICC International Mechanical Code, or CSA B52. All filed joints shall be accessible for inspection before being covered or enclosed.
- All field piping and joints shall be pressure tested with an inert gas according to prevalent industry standards prior to refrigerant charging and system commissioning.
- Where additional field charging is required. The installer shall write with a permanent marker the field charge added on the ODU label provided, such that the Total Charge = Factory 'Pre-charge' + field charge.
- Minimum floor area of the room shall be in compliance with the min. room area according to the total charge of the installation according to Table 1.

Safety Information

- For ducted systems, any auxiliary systems that are potential ignition sources shall not be installed in the duct work. Examples of ignition sources are hot surfaces with temperatures exceeding 1 300°F (700°C) and electric switching devices.
- Any auxiliary device installed must be approved by Samsung and must be suitable for operating with the refrigerant marked on the label.
- For mechanical ventilation the lower edge of the air extraction opening shall not be more than 3.9 inch (100mm) above the floor. The exhaust location outside the building must be at least 9.8ft (3m) away from the building opening and mechanical air intake openings.
- To handle, purge, and dispose of the refrigerant, or break into the refrigerant circuit, the worker should have a certificate from an industry-accredited authority.
- Non-ducted systems may be installed in the areas such as false ceilings not being used as return air plenum as long as the conditioned air does not mix with the air in the false ceilings.
- For ducted appliances false ceilings or drop ceilings may be used as return air plenum if a refrigerant leak detection system is provided in the system and any external connections are also provided with a sensor immediately below the return air plenum duct joint.
- Installation, servicing and any type of maintenance or repair must be performed by certified personnel that is competent to carry such activity in accordance with national and local regulations.

General Information on Servicing

- Do not work in a confined space. Ensure adequate ventilation is provided at the workspace during the entirety of the duration of the work to safely disperse any released refrigerant.
- All maintenance staff and others working in the local area shall be instructed on the nature of the work being performed and instructed to follow all instructions provided by Samsung, national and local authorities.
- The area shall be checked with an approved refrigerant detector before and during any work on the system.
- Have a dry CO₂ fire extinguisher adjacent to the charging area and workspace.
- The service personnel shall not use any ignition sources in a manner that it may lead to the risk of fire or explosion.
- Potential ignition sources shall be kept away from the work area where the flammable refrigerant can be released into the surrounding area.
- The work area should be checked to ensure that there are no flammable hazards or ignition risks. The "No Smoking" sign shall be attached.

- Under no circumstances shall potential sources of ignition be used upon detection of leakage.

The following checks shall be applied to installations and maintenance operations.

- The actual total refrigerant charge is in accordance with the room size in accordance with Table 1.
- The ventilation machinery and outlets are operating adequately and are not obstructed.
- Markings on the equipment are visible and legible.
- Refrigerant pipes or components are installed in a position where they are unlikely to be exposed to any substance which may corrode refrigerant containing components.

Initial checks of electrical devices shall include the following.

- That capacitors are discharged in a safe manner to avoid sparking.
- That no live electrical components and wiring are exposed while charging, recovering or purging the system.
- That there is continuity to earth bonding.
- Check that cabling is not worn, corroded or damaged in any manner.

Electrical repair safety measures

- All electrical components used or replaced must be to Samsung's specifications.
- If a fault exists that could compromise safety, then no electrical supply shall be connected to the circuit until it is satisfactorily dealt with.
- Sealed electrical components and intrinsically safe components shall be replaced and not repaired.
- Cabling should be protected from excessive vibration, pressure, sharp edges, and other adverse environmental factors.

Detection of flammable refrigerants

- Electronic leak detectors shall be used to detect flammable refrigerants, but the sensitivity may not be adequate or may need re-calibration. (Detection equipment shall be calibrated in a refrigerant-free area.)
- Make sure that the detector is not a potential source of ignition.
- Leak detection equipment shall be set at a percentage of the LFL (Lower flammable limit) of the refrigerant and shall be calibrated to the refrigerant employed and the appropriate percentage of gas (25% maximum) is confirmed.

- The use of detergents containing chlorine shall be avoided for cleaning because the chlorine may react with the refrigerant and corrode the piping.
- If leakage is suspected, naked flames shall be removed.
- If a leakage is found while brazing, the entire refrigerant shall be recovered from the product or isolated (e.g. using shut-off valves). It shall not be directly released into the environment. Oxygen-free nitrogen (OFN) shall be used for purging the system before and during the brazing process.
- The work area shall be checked with an appropriate refrigerant detector before and during work.
- Ensure that the leakage detector is appropriate for use with flammable refrigerants.

Removal and Evacuation

- When removing refrigerant for servicing it is recommended to remove the entire quantity.
- When removing refrigerant follow local and national regulations and follow best practices including;
 - evacuate;
 - purge the circuit with inert gas (optional for A2L);
 - evacuate (optional for A2L);
 - continuously flush or purge with inert gas when using flame to open circuit; and
 - open the circuit.
- Use proper recovery cylinders appropriate for the type of refrigerant.
- Follow prescribed industry best practices for purging and evacuation.
- Oxygen free nitrogen shall be used for purging the system.

Charging procedure

- Follow industry standard refrigerant charging best practices.
- Prior to recharging the system shall be pressure tested with oxygen free nitrogen gas.
- Ensure that contamination of different refrigerants does not occur when charging.
- Cylinders shall be kept in the appropriate position as per instructions.
- The refrigerant system should be earthed prior to charging the system.
- Label the system when charging is completed.
- Take extreme care not to overfill the refrigeration system.
- The system shall be leak tested on completion of charging prior to commissioning.

Decommissioning

- Only qualified licensed professionals shall perform refrigerant recovery and decommissioning.
- Isolate the system electrically.
- All recovery equipment and cylinders shall conform to appropriate standards. Only approved cylinders, with pressure relief valves, for the type of refrigerant shall be used.
- Recover refrigerant following industry standard procedure for flammable refrigerants.
- When draining compressors oil care must be taken that there is no flammable refrigerant in the compressor and that the compressor is not hot. Oil should be handled according to local and federal regulations.
- After decommissioning, the system shall be labeled stating that it has been decommissioned. The label shall be dated and signed. The label should state that it "contains flammable refrigerant".
- Ensure that there are labels on the equipment indicating the equipment contains flammable refrigerant.
- Recovered refrigerant shall not be mixed or reused. It shall be processed according to national, state and local regulations.







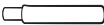

About Refrigerant Detection System(RDS)

- This system includes a refrigerant detection system (RDS) and automatic leak mitigation controls.
- When a leak is detected, the RDS will stop the compressor and energize the indoor unit(s) fan for air circulation to disperse the leaked gas and display an error code.
- The RDS sensor does automatic self-test each hour and does not require any periodic maintenance.
- The sensor should be replaced upon end of life when error Code E700 is displayed.
- For complete replacement instructions, please refer to the Service Manual.
- The RDS sensor must only be replaced with sensors as specified by Samsung. Sensor replacement must be performed by a certified technician.
- MIM-B14U (sold as accessory) which may be used to energize external ventilation fans, as applicable, and close any zone dampers which may be installed in the ductwork, as applicable.
- LEAK DETECTION SYSTEM installed. Unit must be powered except for service.

Installation Procedure

Step 1 Checking and preparing accessories

The following accessories are supplied with the indoor unit. The type and quantity may differ, depending on the specifications.

Pattern sheet (1)	Drain hose (1)
	
Insulation pipe (Liquid side ¹ , gas side ¹)	Insulation drain hose (1)
	
User manual (1)	Installation manual (1)
	
Conduit bracket (1)	Reducer (1)
	
Clamp (1)	Cable-tie (6)
	

Step 2 Choosing the installation location

Installation location requirements

- There must be no obstacles near the air inlet and outlet.
- Install the indoor unit with a ceiling that can support its weight.
- Maintain sufficient clearance around the indoor unit.
- Before installing the indoor unit, check whether the chosen location has proper drainage possibilities.
- The indoor unit must be installed such that it is beyond public access and is not touchable by users.
- A vibration-resistant location that is not inclined (If the indoor unit is installed on a structure that is not sturdy, it may fall and get damaged or cause injury.)
- Where it is not exposed to direct sunshine.
- Where the air filter can be removed and cleaned easily.
- A location where animals cannot access and urinate on the product. Ammonia may be generated.

WARNING

- Because your air conditioner contains R-32 refrigerant, make sure that it is installed, operated, and stored in a room whose floor area is larger than the minimum required floor area specified in the following table:

<Table 1>

m [lbs(kg)]	Minimum required room area [A, ft ² (m ²)]			
	Reference Height [h _r , ft(m)]			
	Ceiling-mounted(with R-32 sensor)			
	7.2(2.2)	8.2(2.5)	8.9(2.7)	10.5(3.2)
≤ 4.047(1.836)	- no room area restrictions -			
4.049(1.837)	58.7(5.46)	51.7(4.80)	47.9(4.45)	40.4(3.75)
4.18(1.9)	60.8(5.64)	53.5(4.97)	49.5(4.60)	41.8(3.88)
4.40(2.0)	64.0(5.94)	56.3(5.23)	52.1(4.84)	44.0(4.08)
4.85(2.2)	70.4(6.54)	61.9(5.75)	57.3(5.33)	48.4(4.49)
5.29(2.4)	76.7(7.13)	67.5(6.27)	62.5(5.81)	52.8(4.90)
5.73(2.6)	83.1(7.72)	73.2(6.80)	67.7(6.29)	57.2(5.31)
6.17(2.8)	89.5(8.32)	78.8(7.32)	73.0(6.78)	61.6(5.72)
6.61(3.0)	95.9(8.91)	84.4(7.84)	78.2(7.26)	66.0(6.13)
7.05(3.2)	102(9.51)	90.1(8.37)	83.4(7.75)	70.4(6.54)

7.49(3.4)	109(10.1)	95.7(8.89)	88.6(8.23)	74.7(6.94)
7.93(3.6)	115(10.7)	101(9.41)	93.8(8.71)	79.1(7.35)
8.37(3.8)	122(11.3)	107(9.93)	99.0(9.20)	83.5(7.76)
8.81(4.0)	128(11.9)	113(10.5)	104(9.68)	87.9(8.17)
9.25(4.2)	134(12.5)	118(11.0)	109(10.2)	92.3(8.58)
9.70(4.4)	141(13.1)	124(11.5)	115(10.7)	96.7(8.99)
10.14(4.6)	147(13.7)	129(12.0)	120(11.1)	101(9.40)
10.58(4.8)	153(14.3)	135(12.6)	125(11.6)	106(9.80)
11.02(5.0)	160(14.9)	141(13.1)	130(12.1)	110(10.2)
11.46(5.2)	166(15.5)	146(13.6)	135(12.6)	114(10.6)
11.90(5.4)	173(16.0)	152(14.1)	141(13.1)	119(11.0)
12.34(5.6)	179(16.6)	158(14.6)	146(13.6)	123(11.4)
12.78(5.8)	185(17.2)	163(15.2)	151(14.0)	128(11.9)
13.22(6.0)	192(17.8)	169(15.7)	156(14.5)	132(12.3)

- m : Total refrigerant charge in the system
- A : Minimum required room area
- Calculated in accordance with UL 60335-2-40 Annex GG
- **IMPORTANT:** It's mandatory to either follow the table above or follow the federal, state, and/or local regulations regarding the minimum room area allowed for the total refrigerant charge in the system.
- The actual refrigerant charge shall be per the room size within which the refrigerant-containing parts are installed.
- The ventilation machinery and outlets shall be operating adequately and not obstructed.
- If an indirect refrigerating circuit is being used, the secondary circuit shall be checked for the presence of refrigerant.
- Marking the equipment shall continue to be visible and legible. Markings and signs that are illegible shall be corrected.
- Refrigerating pipe or components shall be installed in a position where they are unlikely to be exposed to any substance that may corrode refrigerant-containing components unless the components are constructed of materials that are inherently resistant to being corroded or are suitably protected against being so corroded.

CAUTION

As a rule, the unit cannot be installed at a height of less than 8.2ft (2.5m).

- If you install a cassette-type indoor unit in the ceiling when the temperature is over 80.6°F (27°C) and humidity is over 80%, you must apply an extra 0.39inch (10mm) thick polyethylene insulation or a similar type of insulation to the body of the indoor unit.

Do not install the air conditioner in the following places.

- Place where there is mineral oil or arsenic acid. Resin parts flame and the accessories may drop or water may leak. The capacity of the heat exchanger may be reduced, or the air conditioner may be out of order.
- A place with exposure to mineral oil, oil vapor or a cooking area where there is spray (If oil adheres to the heat exchanger, performance degradation, spray or condensation scattering may occur. If oil adheres to a plastic component, the component may deform or get damaged. Such issues may result in a system failure or refrigerant leak.)
- A place with aromatic diffusers, aromatherapy, scented candles or perfumes as the chemicals may react to the product's materials and may result in system failure or refrigerant leaks.
- The place where corrosive gas such as sulphuric acid gas is generated from the vent pipe or air outlet.
- The copper pipe or connection pipe may corrode and the refrigerant may leak.
- The place where there is a machine that generates electromagnetic waves. The air conditioner may not operate normally due to the control system.
- The place where there is a danger of existing combustible gas, carbon fiber or flammable dust.
- The place where thinner or gasoline is handled. Gas may leak and it may cause fire.
- The place that is close to heat sources.
- Do not use the indoor unit for the preservation of food items, plants, equipment, and artwork. This may cause deterioration of their quality.
- Do not install the indoor unit if it has any drainage problems.

Installation Procedure

Indoor unit dimensions

Unit : inch(mm)

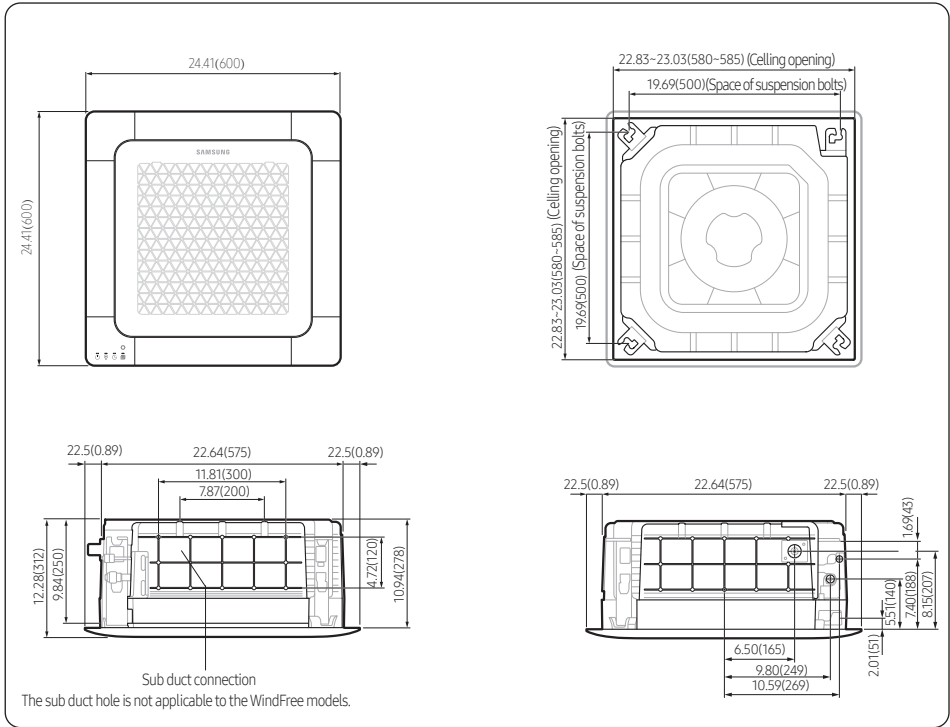

Model		AC009DNNDGC	AC012DNNDGC	AC018DNNDGC
Net dimension (W × D × H)	inch(mm)	22.64X22.64X9.84 (575X575X250)		
Liquid pipe connection	inch(mm)	Ø1/4 (6.35)		
Gas pipe connection	inch(mm)	Ø3/8 (9.52)		Ø1/2 (12.70)
Drain hose connection	inch(mm)	3/4 inch [OD 1.05 inch (26.67 mm)]		

Spacing requirements

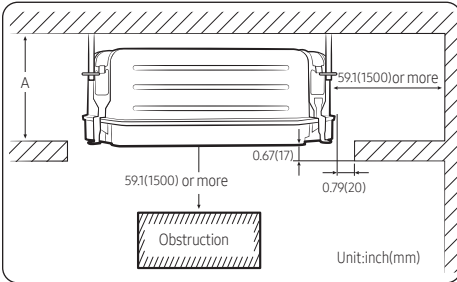

Model	AC***DNND CG
A	11.69(297)
Net dimension	22.64X9.84X22.64 (575X250X575)

Unit: inch (mm)

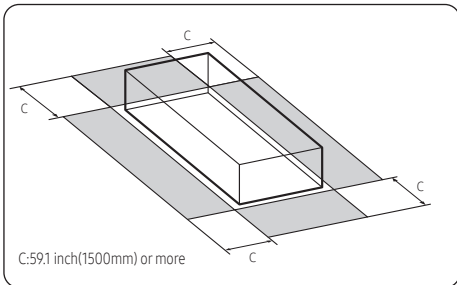

CAUTION

- Comply with the length and height limits described in the figure above.
- The indoor unit must be installed according to the specified clearances to permit accessibility from each side, and to guarantee correct operation, maintenance, and repair of the unit. The components of the indoor unit must be reachable and removable under safe conditions for people and the unit.
- Do not carry the unit by holding the refrigerant or drainpipes to avoid product damage.
- Carry the unit by holding the hanger plates located on the corners of the unit.

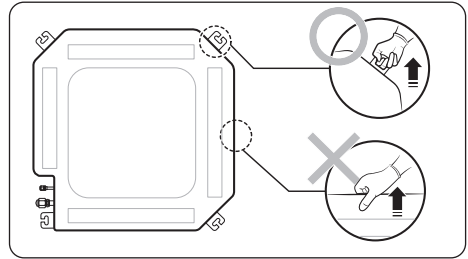

Step 3 Optional: Insulating the body of the indoor unit

If you install a cassette-type indoor unit on the ceiling when the temperature is over 80.6 °F (27 °C) and humidity is over 80%, you must apply an extra 0.39 inch (10 mm) thick polyethylene insulation or a similar type of insulation to the body of the indoor unit.

Cut away the part where pipes are pulled out for the insulating work.

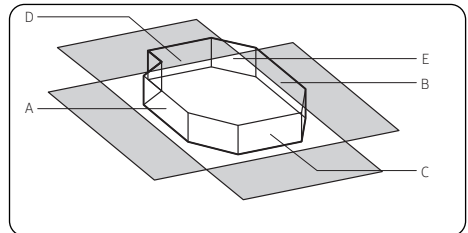

Insulate the end of the pipe and some curved areas by using a separate insulator.

NOTE

- A: Reference for the outer circumference of the unit (When insulating the body of the indoor unit, use A as the reference for its outer circumference.)

A	B	C	D	E
15.75X7.48 (400X190)	15.75X7.48 (400X190)	15.75X7.48 (400X190)	15.75X7.48 (400X190)	21.65X21.65 (550X550)

Unit:inch (mm)

Installation Procedure

Step 4 Installing the indoor unit

When deciding on the location of the air conditioner the following restrictions must be considered.

- 1 Place the pattern sheet on the ceiling at the spot where you want to install the indoor unit.

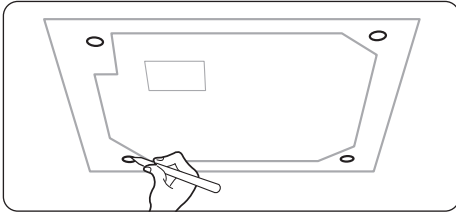

NOTE

- Since the diagram is made of paper, it may shrink or stretch slightly due to temperature or humidity. For this reason, before drilling the holes, be sure to maintain the correct dimensions between the markings.
- 2 Insert bolt anchors, use existing ceiling supports or construct a suitable support as shown in the figure.

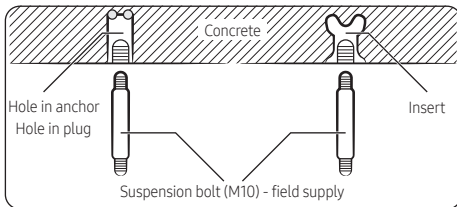

- 3 Install the suspension bolts, depending on the ceiling type.

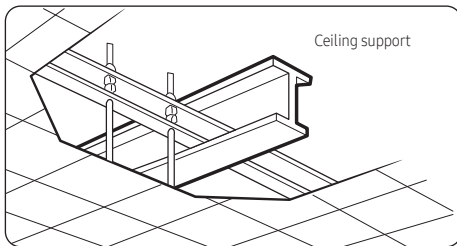

CAUTION

- Make sure that the ceiling is strong enough to support the weight of the indoor unit. Before hanging the unit, test the strength of each attached suspension bolt.
 - If the length of the suspension bolt is more than 4.9 ft (1.5 m), you are required to prevent vibration.
- 4 Screw eight pairs of nuts and washers to the suspension bolts, making space for hanging the indoor unit.

CAUTION

- You must install all of the suspension rods.
 - It is important to leave sufficient space in the false ceiling to allow access for maintenance or repairs to the drainage pipe connection, and the refrigerant pipe connection, or to remove the unit if necessary.
- 5 Hang the indoor unit to the suspension bolts between two nuts. Cut a pad stopper and place it on the suspension bolts to hold the washers. Remove the stopper and screw the nuts to fix the unit.

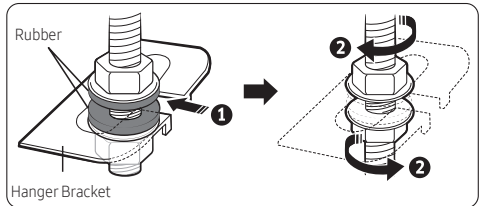

- Adjust the unit to the appropriate position, considering the installation area for the front panel.
 - Place the pattern sheet on the indoor unit.
 - Adjust the space between the ceiling and the indoor unit by using a dimension gauge.
 - Fix the indoor unit securely after adjusting the level of the unit by using a level.
 - Remove the pattern sheet, connect the other cables, and install the front panel.

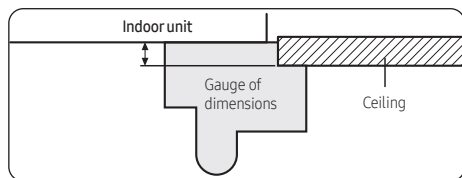

Step 5 Purging inert gas from the indoor unit

The indoor unit comes with nitrogen gas (inert gas) charged at the factory. Therefore, all inert gas must be purged before connecting the assembly piping.

Unscrew the pinch pipe at the end of each refrigerant pipe.

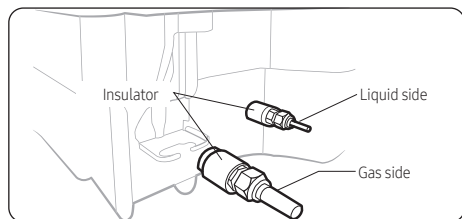

NOTE

- To prevent dirt or foreign objects from getting into the pipes during installation, do not remove the pinch pipe completely until you are ready to connect the piping.

Step 6 Cutting and flaring the pipes

- Make sure that you have the required tools available: pipe cutter, reamer, flaring tool, and pipe holder.
- If you wish to shorten the pipes, cut them with a pipe cutter, ensuring that the cut edge remains at a 90° angle to the side of the pipe. Refer to the illustrations below for examples of edges cut correctly and incorrectly.

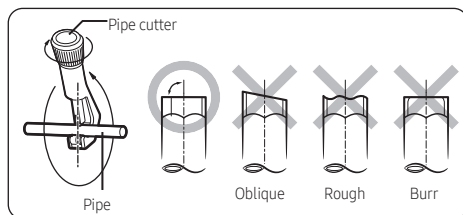

- To prevent any gas from leaking out, remove all burrs at the cut edge of the pipe, using a reamer.
- Slide a flare nut onto the pipe and modify the flare.

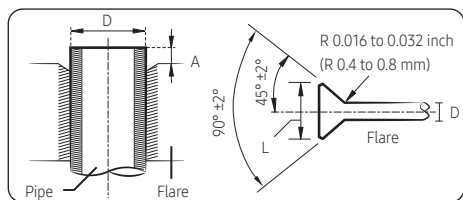

Outer Diameter (D)	Depth (A)	Flare dimension (L)
Ø1/4 (6.35)	0.051 (1.3)	0.34-0.36 (8.7-9.1)
Ø3/8 (9.52)	0.071 (1.8)	0.50-0.52 (12.8-13.2)
Ø1/2 (12.70)	0.079 (2.0)	0.64-0.65 (16.2-16.6)
Ø5/8 (15.88)	0.087 (2.2)	0.76-0.78 (19.3-19.7)

Unit:inch (mm)

- Check that the flaring is correct, refer to the illustrations below for examples of incorrect flaring.

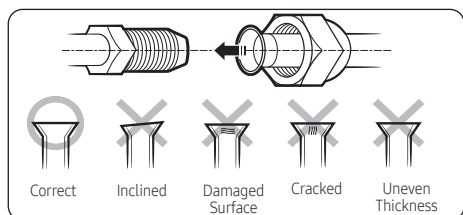

Installation Procedure

Step 7 Connecting the assembly pipes to the refrigerant pipes

There are two refrigerant pipes of different diameters:

- A smaller one for the liquid refrigerant.
 - A larger one for the gas refrigerant. The inside of the copper pipe must be clean and have no dust.
- 1 Remove the pinch pipe on the pipes and connect the assembly pipes to each pipe, tightening the nuts, first manually and then with a torque wrench, and a spanner applying the following torque.

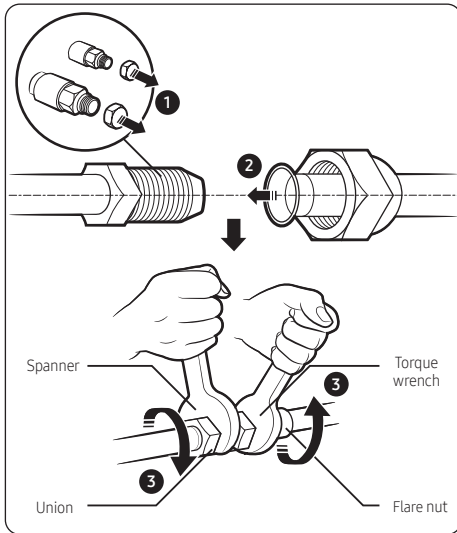

NOTE

- If the pipes must be shortened, see **Step 6 Cutting and flaring the pipes** on page 13.
- 2 Be sure to use an insulator that is thick enough to cover the refrigerant tube to protect the condensate water on the outside of the pipe from falling onto the floor and to improve the efficiency of the unit.
 - 3 Cut off any excess foam insulation.
 - 4 Be sure that there are no cracks or waves on the bent area.
 - 5 It would be necessary to double the insulation thickness [0.39 inch (10 mm) or more] to prevent condensation even on the insulator when the installed area is warm and humid.
 - 6 Do not use joints or extensions for the pipes connecting the indoor and outdoor units. The only permitted connections are those for which the units are designed.

CAUTION

- Connect the indoor and outdoor units using pipes with flared connections (not supplied). For the lines, use insulated, unwelded, degreased and deoxidized copper pipe (Cu DHP type to ISO 1337 or UNI EN 12735-1). Operating pressure depends on outdoor unit specifications. Check the outdoor unit installation manual. Copper pipes for hydro-sanitary applications are completely unsuitable.
- For sizing and limits (height difference, line length, max. bends, refrigerant charge, etc.) see the outdoor unit installation manual.
- All refrigerant connections must be accessible, to permit either unit maintenance or removing it completely.
- If the pipes require brazing, make sure that oxygen-free nitrogen (OFN) is flowing through the system.
- The nitrogen blowing pressure range is 0.02 to 0.05 MPa (2.9 to 7.3 psi).

Outer Diameter		Torque	
mm	inch	N•m	lbfft
Ø6.35	1/4	14 to 18	10.3 to 13.3
Ø9.52	3/8	34 to 42	25.1 to 31.0
Ø12.70	1/2	49 to 61	36.1 to 45.0
Ø15.88	5/8	68 to 82	50.2 to 60.5

(1 N•m=10 kgf•cm)

Step 8 Performing the gas leak test

To identify potential gas leaks in the indoor unit, inspect the connection area of each refrigerant pipe using a leak detector for R-32.)

Before creating a vacuum and adding refrigerant, pressurize the whole system with nitrogen using a cylinder with a pressure reducer at a pressure above 0.2 MPa(29.0 psi), less than 4.0 MPa(580 psi) (gauge) to detect leaks on the refrigerant fittings.

Refer to the outdoor unit installation manual for the complete steps for pressure testing and vacuuming the system before charging with refrigerant.

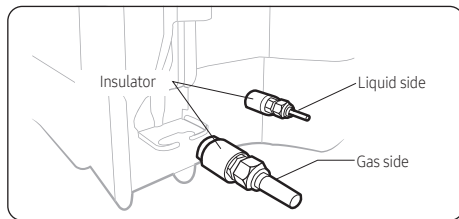

Step 9 Insulating the refrigerant pipes

Once you have checked that there are no leaks in the system, you can insulate the piping and hose.

- To avoid condensation problems, place Acrylonitrile Butadiene Rubber separately around each refrigerant pipe.

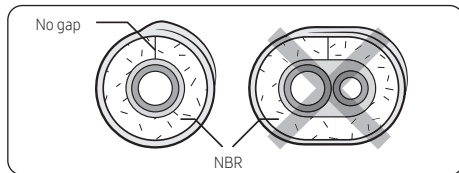

NOTE

- Always make the seam of pipes face upwards.
- Wind insulating tape around the pipes and drain hose to avoid compressing the insulation too much.

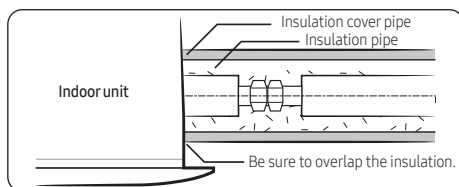

CAUTION

- Be sure to wrap the insulation tightly without any gaps.
- Finish wrapping insulating tape around the rest of the pipes leading to the outdoor unit.
 - The pipes and electrical cables connecting the indoor unit with the outdoor unit must be fixed to the wall with suitable ducts.

CAUTION

- Make sure that all refrigerant connections are accessible for easy maintenance and detachment.
- Install the insulation not to get wider and use the adhesives on the connection part of it to prevent moisture from entering.
- Wind the refrigerant pipe with insulation tape if it is exposed to outside sunlight.
- Install the refrigerant pipe respecting that the insulation does not get thinner on the bent part or hanger of pipe.
- Add additional insulation if the insulation plate gets thinner.

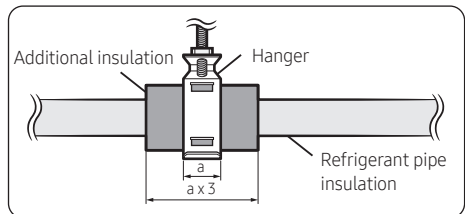

- Select the insulation of the refrigerant pipe.
 - Insulate the gas side and liquid side pipe, noting the insulation thickness that must differ according to the pipe size.
 - Standard: Less than an indoor temperature of 86°F (30°C), with humidity at 85%. If installing in a high humidity environment, use one grade thicker insulator by referring to the table below. If installing in an unfavorable environment, use a thicker one.
 - The heat-resistance temperature of the insulator must be more than 248°F (120°C).

CAUTION

- The insulation must fit tightly against the body without any gap.
- All refrigerant connections must be accessible, to permit either unit maintenance or removal.

Installation Procedure

Pipe	Pipe size inch (mm)	Insulation type (heating / cooling)		Remarks
		Standard [Less than 86°F (30°C), 85%]	High humidity [Over 86°F (30°C), 85%]	
		EPDM, NBR		
Liquid pipe	Ø1/4 (6.35) to Ø3/8 (9.52)	9 t	9 t	The internal temperature is higher than 248°F (120°C).
	Ø1/2 (12.70) to Ø3/4 (19.05)	13 t	13 t	
Gas pipe	Ø1/4 (6.35)	13 t	19 t	
	Ø3/8 (9.52)	19 t	25 t	
	Ø1/2 (12.70)			
	Ø5/8 (15.88)			

- When installing insulation in the places and conditions below, use the same insulation that is used for high humidity conditions.

<Geological condition>
High humidity locations such as shorelines, hot springs, lakes or riversides, and ridges (when part of the building is covered by earth and sand)
<Operation purpose condition>
Restaurant ceiling, sauna, swimming pool etc.
<Building construction condition>
Ceilings frequently exposed to moisture and cooling are not covered. For example, pipes installed in a corridor of a dormitory and studio or near an exit that opens and closes frequently. Places (where the pipes are installed) that are highly humid due to a lack of ventilation.

Step 10 Installing the drain hose and drainpipe

- Push the supplied drain hose as far as possible over the drain socket.
- Tighten the metal clamp as shown in the picture.

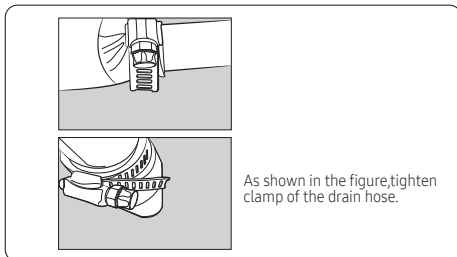

- Wrap the supplied large sealing pad over the metal clamp and drain hose to insulate and fix it with clamps.

- Insulate the complete drain piping inside the building (field supply).
If the drain hose cannot be sufficiently set on a slope, fit the hose with drain raising piping (field supply).
- Push the drain hose up to insulation when connecting the drain hose to the drain socket.

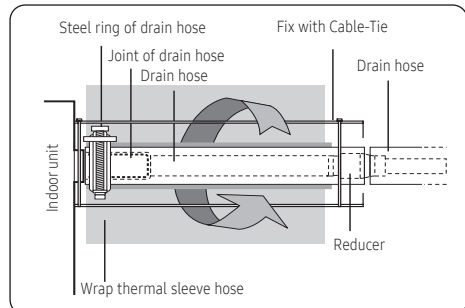

CAUTION

Check that the indoor unit is level with the ceiling by using the level.

- Install a drain vent to drain condensation smoothly.

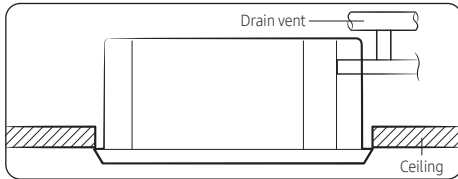

- Place the drainpipe at a height of 11.81 to 21.65 inches (300 to 550 mm) within 11.81 inches (300 mm) from the drain hose, and install it with a drop-off of at least 0.79 inch (20 mm).
- If the slope of the horizontal drainpipe is less than 1/100, install an air vent with a height of at least 7.87 inches (200 mm) or a backflow prevention vent at each drain inlet, to ensure smooth condensate flow.
- If the slope of the drainpipe is less than 1/100 and no air vent is installed, the air conditioner will not operate properly because condensate is not discharged.
- If an air vent with a height less than 7.87 inches (200 mm) or a vent without backflow prevention functionality is installed, the drainpipe may become clogged, causing water to leak through the vent.

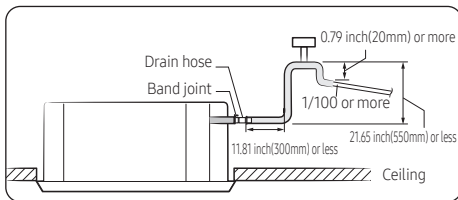

- Do not give the hose an upward gradient beyond the connection port. This will cause water to flow backward when the unit is stopped, resulting in water leaks.

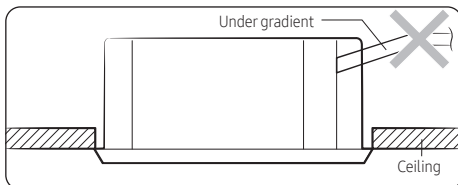

- Do not apply force to the piping on the unit side when connecting the drain hose. The hose should not be allowed to hang loose from its connection to the unit. Fasten the hose to a wall, frame or other support as close to the unit as possible.
- Install the horizontal drainpipe and copper pipe at an incline of at least 1/100 and attach a full-thread bolt hanger every 39.37 to 59.05 inches (1 to 1.5 m) along the pipe to fix it in place.

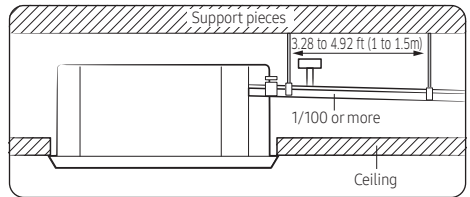

- Install horizontally.

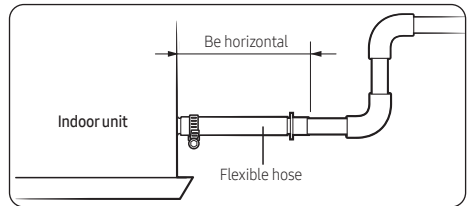

- Max. allowable axis gap.

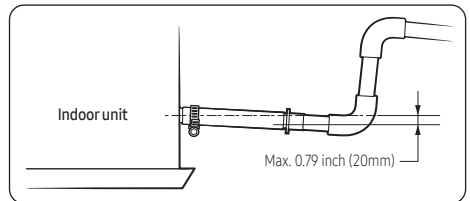

- Max. allowable bending angle.

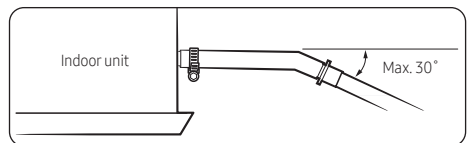

NOTE

- If a common drainpipe is installed, refer to the figure below.

Installation Procedure

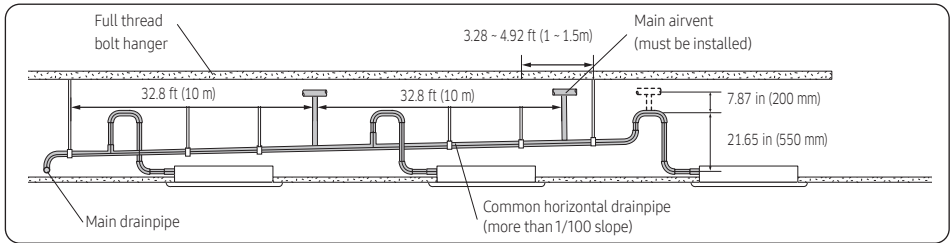

- If 3 or more units are installed, install a main air vent in front of the farthest indoor unit from the main drainpipe.
- To prevent water from flowing back to indoor units, install an individual air vent at the top of each indoor unit.
 - The air vents should be T or 7 shaped to prevent dust or foreign substances from entering.
 - You may not need to install an air vent if the horizontal drainpipe has a proper slope.
 - If the length of the centralized horizontal drainpipe is more than 10 meters, install a main air vent every 32.8 ft (10 m) meters.
 - Install a main air vent in front of the indoor unit farthest from the main drain hole if the centralized horizontal drainpipe is more than 32.8 ft (10 m) long.
 - Install the centralized horizontal drainpipe at an incline of more than 1/100 and fix it with bolt hangers at intervals of 3.28 ft to 4.92 ft (1 to 1.5 meters).
 - If the slope of the centralized horizontal drainpipe is less than 1/100, install an individual air vent or anti-backflow vent at the entrance of the individual drainpipe to facilitate the flow of condensed water.
 - The air conditioner may not function properly because of poor condensation water drainage if an air vent is not installed when the slope of the main drainpipe is less than 1/100.
 - If a height of 7.87 inches (200 mm) or higher vents or anti-backflow vents are not installed, blockage of the drainpipe may cause backflow through an air vent.

Installation Procedure

Step 11 Performing the drainage test

- 1 Do a leak test at the connection part of the flexible hose and the drainpipe:
 - a Connect a general hose to the connection part of the flexible hose of the indoor unit and pour in some water.

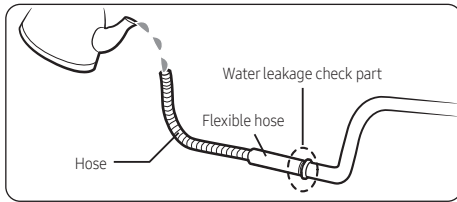

- b After pouring some water, reassemble the rubber cap on the connection part of a flexible hose of the indoor unit and firmly tighten it with a band to prevent leakage.
- c Check the leak test at the part where the adhesive for the flexible hose and the drainpipe are used.

⚠ CAUTION

- The leak test must be performed for at least 24 hours.
- 2 Check the condensed water drainage:
 - a Pour about 0.53 gallons (2 liters) of water into the indoor unit drain pan as shown in the picture.

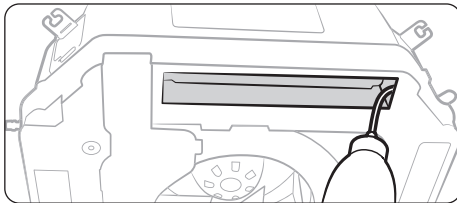

- b When the electric cable connection is completed
 - Turn on the indoor unit and outdoor unit.
 - Operate in the Cool mode.

⚠ CAUTION

- Only in the Cool mode, you can check the correct operation of the drain pump.

When the electric cable connection has not been completed

- Remove the control box cover of the indoor unit.
- Connect the power supply (208~230V, 60 Hz) to the L and N terminals.
- Reassemble the control box cover and turn on the indoor unit.

⚠ CAUTION

- When the float switch is not detected due to insufficient water on the drain pan, the drain pump will not work.
 - If the power supply is directly connected to the L and N terminals, a communication error message might appear.
 - After completing the drainage check, turn the unit off and disconnect the power supply.
 - Reassemble the control box cover.
- c Check whether the drain pump works correctly.
 - d Check whether the drainage is performing correctly at the end of the drainpipe.
 - e Check for leakage at the drainpipe and drainpipe connection part.
 - f When leakage occurs, check whether the indoor unit is level and check the drain hose connection part, drainpipe connection part and drain pump connection.
 - g When the drainage check is completed and the condensed water remains on the drain pan, remove the water.

Installation Procedure

Wiring work

Selecting compressed ring terminal

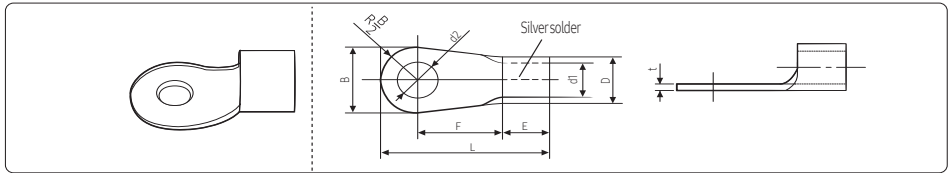

Nominal dimensions for cable [Inch ² (mm ²)]		0.002 (1.5)		0.003 (2.5)		0.006 (4)
Nominal dimensions for screw [Inch (mm)]		0.15 (4)	0.15 (4)	0.15 (4)	0.15 (4)	0.15 (4)
B	Standard dimension [Inch (mm)]	0.25 (6.6)	0.31 (8.0)	0.25 (6.6)	0.33 (8.5)	0.37 (9.5)
	Allowance [Inch (mm)]	±0.007 (±0.2)		±0.007 (±0.2)		±0.007 (±0.2)
D	Standard dimension [Inch (mm)]	0.13 (3.4)		0.16 (4.2)		0.22 (5.6)
	Allowance [Inch (mm)]	+0.011 (+0.3) -0.007 (-0.2)		+0.011 (+0.3) -0.007 (-0.2)		+0.011 (+0.3) -0.007 (-0.2)
d1	Standard dimension [Inch (mm)]	0.06 (1.7)		0.09 (2.3)		0.13 (3.4)
	Allowance [Inch (mm)]	±0.007 (±0.2)		±0.007 (±0.2)		±0.007 (±0.2)
E	Min. [Inch (mm)]	3/16 (4.1)		1/4 (6)		1/4 (6)
F	Min. [Inch (mm)]	1/4 (6)		1/4 (6)		1/4 (6)
L	Max. [Inch (mm)]	5/8 (16)		3/4 (17.5)		3/4 (20)
d2	Standard dimension [Inch (mm)]	0.16 (4.3)		0.16 (4.3)		0.16 (4.3)
	Allowance [Inch (mm)]	+0.007 (+0.2) 0 (0)		+0.007 (+0.2) 0 (0)		+0.007 (+0.2) 0 (0)
t	Min. [Inch (mm)]	0.02 (0.7)		0.03 (0.8)		0.035 (0.9)

Step 12 Connecting the power and communication cables

Bushing bracket installation

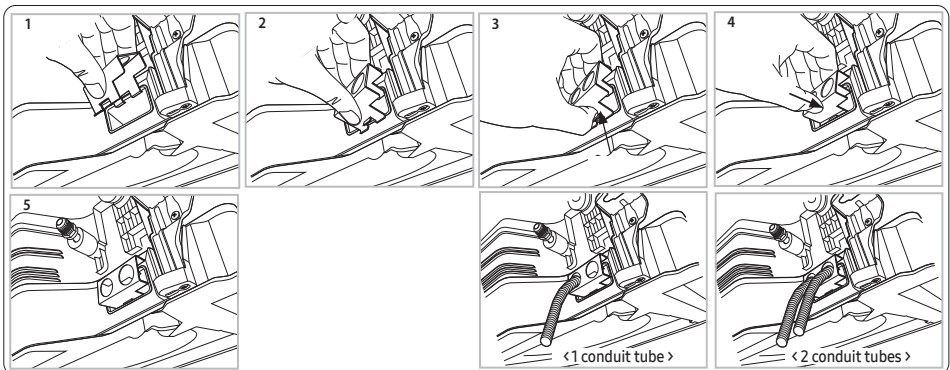

⚠ CAUTION

- Always remember to connect the refrigerant pipes before performing the electric connections. When disconnecting the system, always disconnect the electric cables before disconnecting the refrigerant pipes.

⚠ CAUTION

- Always connect the air conditioner to the grounding system before performing the electric connections. Use a crimp ring terminal at the end of each wire.
- For the product that uses the R-32 refrigerant, be cautious not to generate a spark by keeping the following requirements:
 - Do not remove fuses with power on.
- Always remember to connect the air conditioner to the grounding system before performing the electric connections. Use a crimp ring terminal at the end of each wire.

The indoor unit is powered through the outdoor unit using a H05RN-F (60245 / IEC57) connection cable (or a more powerful model), with insulation in synthetic rubber and a jacket in polychloroprene (neoprene), following the requirements specified in the standard EN 60335-2-40.

- Remove the screw on the electrical component box and remove the cover plate.
- Route the connection cord through the side of the indoor unit and connect the cable to the terminals refer to the figure below.
- Route the other end of the cable to the outdoor unit through the ceiling & the hole in the wall.
- Reassemble the electrical component box cover, carefully tightening the screw.

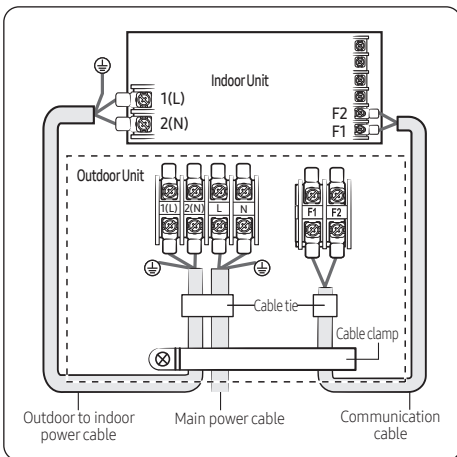

Indoor power supply		
Power supply	Max/Min(V)	Indoor power cable
208 to 230V,60 Hz	±10%	AWG18↑, 3 wires
Communication cable		
AWG18↑, 2 wires		

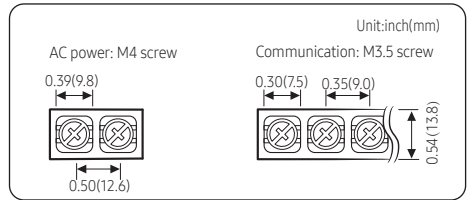

Tightening torque lbf•ft (kgf•cm)	
M3.5	0.58 to 0.87 (8.0 to 12.0)
M4	0.87 to 1.30 (12.0 to 18.0)

- 1 N•m = 10 kgf•cm
- Power supply cords of parts of appliances for outdoor use shall not be lighter than polychloroprene sheathed flexible cords. (Code designation IEC:60245 IEC 57 / CENELEC: H05RN-F)
- Since it has an external power supply, refer to the outdoor unit installation manual for MAIN POWER.

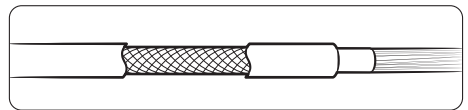

⚠ CAUTION

- When installing the indoor unit in a computer room or network room, use the double shielded communication cable (tape aluminum / polyester braid + copper) of FROHH2R or LIYCY type.

Installation Procedure

Step 13 optional : Setting the Emergency Temperature Output (ETO) function

Emergency Temperature Output (ETO) function (for the multi system, this function is not supported.)

CAUTION

- To deploy the ETO function, the MIM-B14 or MIM-B14U, an external contact interface module, must be installed in each indoor unit.
- To use the ETO function, should use S-NET Pro 2.
- The ETO is a concept of emergency operation of indoor units. If indoor unit 1 (main indoor unit) stops because of an error, indoor unit 2 (sub-indoor unit) starts to operate.
- Basically, indoor unit 2 operates in the previous mode. [For the first time operation, it starts in 75 °F (24 °C) Auto mode.]
- To set more detailed operation conditions for the indoor unit 2, use the S-net Pro 2.

Setting up the ETO

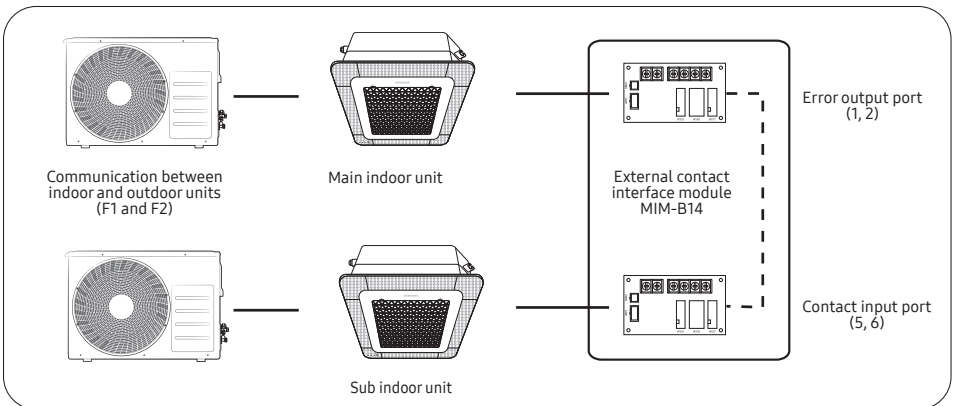

- 1 Main indoor unit
 - Disable the external contact control (Default).
 - Connect the S-net pro 2 to F1 and F2.
 - Enable the ETO function and set the temperature and time.
- 2 Sub indoor unit
 - (Required) Enable the external contact control (with the installation option SEG14 - Reverse Control).
 - Connect the S-net pro 2 to F1 and F2.
 - Enable the entrance control and set the mode, temperature, and fan speed.

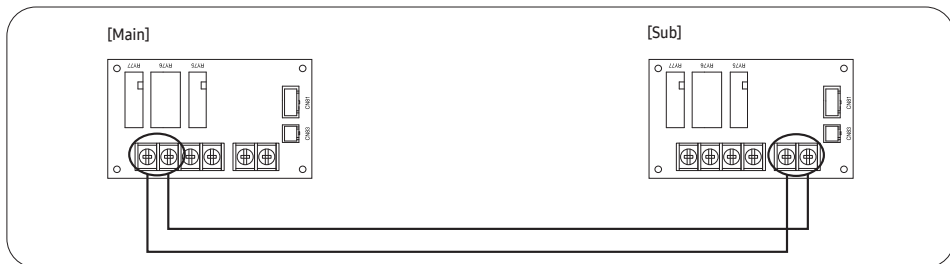

ETO operation specifications

See the details for SEG 14 and SEG 15 in the table titled '02 series installation option'.

1 Main indoor unit

- Based on the external contact control settings, the main indoor unit decides whether to generate output when an error (indoor unit stop) occurs.
- Based on the ETO settings, the main indoor unit decides whether to generate output according to the temperature and time conditions.

2 Sub indoor unit





- Based on the entrance control settings, the sub-indoor unit decides the mode, set temperature, and fan speed when contact inputs are given.

	Enable ETO	Enable external contact	Error port output
Main indoor unit	X	X	N/A
	X	O	Output due to an error
	O	X	Output by ETO entrance conditions (temperature / time / error occurrence)
	O	O	Output by ETO entrance conditions (temperature / time / error occurrence) ✳ Ready to control the main contact input
Sub indoor unit	Enable entrance control	Enable external contact	Operation when outputting the Main
	X	X	N/A
	X	O	On with the previous operation conditions
	O	O	On with the entrance control enabled



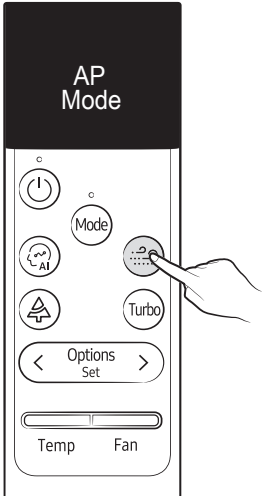
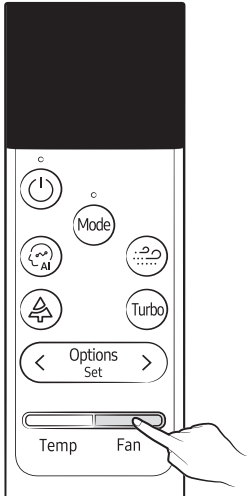
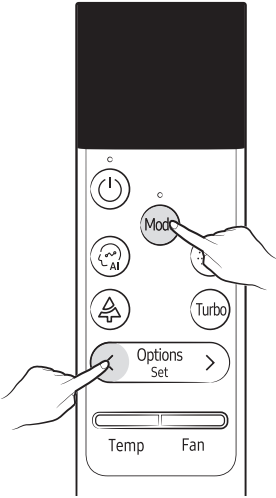

Installation Procedure

Step 14 Optional : LED Display indicator specifications when checking Wi-Fi Easy Setup and Wi-Fi status

The wireless remote control can be used for Easy Setup, checking the internet connection status and connecting or disconnecting Wi-Fi.

Easy Setup	Check internet connection status	Connect/Disconnect to Wi-Fi
		
<p>Press the  button for 5 seconds</p>	<p>Press the  button for 5 seconds</p>	<p>Press the  and  button for 5 seconds</p>

LED indicator Status

4way Cassette		LED Display				Remarks	Measure
		Power/Stop	Defrost	Timed on/off	Clean filter		
							
Easy Setup	AP entry	●	●	●	●	All LED lights are on	-
	Check device	◐	◐	◐	◐	All LED lights flash	-
	Registering devices	◐	◐	◐	◐	All LED lights flash one after another	-
	Connected	◐	◐	◐	◐	All LED lights flash for 3 seconds	-
	Connection failed	X	X	X	X	All LED lights turn off, and the system operates in the previous mode	AP settings, change Wi-Fi module
Check internet connection status	If AP/internet is connected successfully	●	●	●	●	All LED lights turn on for 5 seconds	Normal operation
	If no AP connection	X	X	X	X	All LEDs turn off for 5 seconds	AP settings, change Wi-Fi module
Wi-Fi	If connected	◐	◐	◐	◐	All LED lights flash once	-
	If not connected						-
If AP is set up using the wired remote controller		◐	◐	◐	◐	All LED lights flash simultaneously (max. 10 mins)	-
Connection info reset		◐	◐	◐	◐	All LED lights flash in order (order: On/Off → ●●● → filter cleaning)	-
All devices reset		◐	◐	◐	◐	All LED lights flash in order (order: filter cleaning → ●●● → On/Off)	-

Installation Procedure

Step 15 Setting the indoor unit addresses and the installation options

You cannot set both indoor unit addresses and the installation options in a batch: set both of them respectively.

Common steps for setting the addresses and options

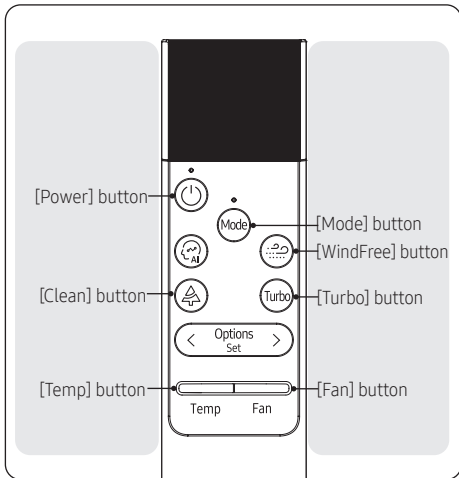

NOTE

- The remote control display and buttons may vary depending on the model.

1 Enter the mode for setting the options.

- Reset remote control : [Temp] button Down + [Fan] button Down + [Mode] Press for 10 seconds.
- You can see the "SW Initialization" message and enter the following in 5 seconds.
- Press [WindFree] button and [Turbo] button for 5 seconds.
- Make sure that you are entered into the mode for setting options:

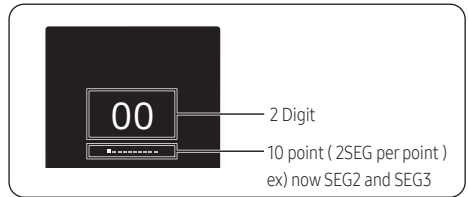

2 Set the option values.

CAUTION

























- The total number of available options is 24 : SEG1 to SEG24.
- Because SEG1, SEG7, SEG13, and SEG19 are the page options used by the previous remote control models, the modes to set values for these options are skipped automatically.
- You can see 20 SEG (except SEG1, SEG7, SEG13, SEG19 SEG2 → ... → SEG6 → SEG8 → → SEG12 → SEG 14 → → SEG 18 → SEG20 → ... → SEG 24

SEG1	SEG2	SEG3	SEG4	SEG5	SEG6
0	X	X	X	X	X
SEG7	SEG8	SEG9	SEG10	SEG11	SEG12
1	X	X	X	X	X
SEG13	SEG14	SEG15	SEG16	SEG17	SEG18
2	X	X	X	X	X
SEG19	SEG20	SEG21	SEG22	SEG23	SEG24
3	X	X	X	X	X



















- You can set the next SEG by pressing the mode button.
- You can change the digit value through the following operation.

















Left value : up or down, range : 0 ~ F
 Right value : up or down, range : 0 ~ F

Take the steps presented in the following table:

























Steps	Remote control display
<p>1 Set the SEG2 and SEG3 values:</p> <p>a Set the SEG2 value by pressing the  button repeatedly until the value you want to set appears on the remote control display.</p> <p>b Set the SEG3 value by pressing the  button repeatedly until the value you want to set appears on the remote control display.</p> <p>When you press the  or  button, values appear in the following order:  →  → ... →  → </p>	 <p style="text-align: center;">SEG2</p>  <p style="text-align: center;">SEG3</p>
<p>2 Press the  button to move to the next page.</p>	
<p>3 Set the SEG4 and SEG5 values:</p> <p>a Set the SEG4 value by pressing the  button repeatedly until the value you want to set appears on the remote control display.</p> <p>b Set the SEG5 value by pressing the  button repeatedly until the value you want to set appears on the remote control display.</p> <p>When you press the  or  button, values appear in the following order:  →  → ... →  → </p>	 <p style="text-align: center;">SEG4</p>  <p style="text-align: center;">SEG5</p>
<p>4 Press the  button to move to the next page.</p>	























Installation Procedure

Steps	Remote control display
<p>5 Set the SEG6 and SEG8 values:</p> <p>a Set the SEG6 value by pressing the  button repeatedly until the value you want to set appears on the remote control display.</p> <p>b Set the SEG8 value by pressing the  button repeatedly until the value you want to set appears on the remote control display.</p> <p>When you press the  or  button, values appear in the following order: </p>	 <p>SEG6</p>  <p>SEG8</p>
<p>6 Press the  button to move to the next page.</p>	
<p>7 Set the SEG9 and SEG10 values:</p> <p>a Set the SEG9 value by pressing the  button repeatedly until the value you want to set appears on the remote control display.</p> <p>b Set the SEG10 value by pressing the  button repeatedly until the value you want to set appears on the remote control display.</p> <p>When you press the  or  button, values appear in the following order: </p>	 <p>SEG9</p>  <p>SEG10</p>
<p>8 Press the  button to move to the next page.</p>	

Steps	Remote control display
<p>9 Set the SEG11 and SEG12 values:</p> <p>a Set the SEG11 value by pressing the  button repeatedly until the value you want to set appears on the remote control display.</p> <p>b Set the SEG12 value by pressing the  button repeatedly until the value you want to set appears on the remote control display.</p> <p>When you press the  or  button, values appear in the following order: 0 → 8 → ... E → F</p>	 <p>SEG11</p>  <p>SEG12</p>
<p>10 Press the  button to move to the next page.</p>	
<p>11 Set the SEG14 and SEG15 values:</p> <p>a Set the SEG14 value by pressing the  button repeatedly until the value you want to set appears on the remote control display.</p> <p>b Set the SEG15 value by pressing the  button repeatedly until the value you want to set appears on the remote control display.</p> <p>When you press the  or  button, values appear in the following order: 0 → 8 → ... E → F</p>	 <p>SEG14</p>  <p>SEG15</p>
<p>12 Press the  button to move to the next page.</p>	

Installation Procedure

Steps	Remote control display
<p>13 Set the SEG16 and SEG17 values:</p> <p>a Set the SEG16 value by pressing the  button repeatedly until the value you want to set appears on the remote control display.</p> <p>b Set the SEG17 value by pressing the  button repeatedly until the value you want to set appears on the remote control display.</p> <p>When you press the  or  button, values appear in the following order:  →  → ... →  → </p>	 <p>SEG16</p>  <p>SEG17</p>
<p>14 Press the  button to move to the next page.</p>	
<p>15 Set the SEG18 and SEG20 values:</p> <p>a Set the SEG18 value by pressing the  button repeatedly until the value you want to set appears on the remote control display.</p> <p>b Set the SEG20 value by pressing the  button repeatedly until the value you want to set appears on the remote control display.</p> <p>When you press the  or  button, values appear in the following order:  →  → ... →  → </p>	 <p>SEG18</p>  <p>SEG20</p>
<p>16 Press the  button to move to the next page.</p>	

Steps	Remote control display
<p>17 Set the SEG21 and SEG22 values:</p> <p>a Set the SEG21 value by pressing the  button repeatedly until the value you want to set appears on the remote control display.</p> <p>b Set the SEG22 value by pressing the  button repeatedly until the value you want to set appears on the remote control display.</p> <p>When you press the  or  button, values appear in the following order:  →  → ... →  → </p>	 <p>SEG21</p>  <p>SEG22</p>
<p>18 Press the  button to move to the next page.</p>	
<p>19 Set the SEG23 and SEG24 values:</p> <p>a Set the SEG23 value by pressing the  button repeatedly until the value you want to set appears on the remote control display.</p> <p>b Set the SEG24 value by pressing the  button repeatedly until the value you want to set appears on the remote control display.</p> <p>When you press the  or  button, values appear in the following order:  →  → ... →  → </p>	 <p>SEG23</p>  <p>SEG24</p>



Installation Procedure



- 3 Check whether the option values you have set are correct by pressing the  button repeatedly.





EX) AC009DNNDCG

020010-100001-200020-300000

- 4 Save the option values into the indoor unit:
 Point the remote control to the remote control sensor on the indoor unit and then press the  button on the remote control twice.
 Make sure that this command is received by the indoor unit. When it is successfully received, you can hear a short sound from the indoor unit. If the command is not received, press the  button again.
- 5 Check whether the air conditioner operates following the option values you have set:

- a Reset the indoor or outdoor unit.
- Indoor Unit : Press  button +  button for 5 seconds
 - Outdoor Unit: Press the K3 button

- b Reset remote control:  button Down +  button Down +  Press for 10 seconds
 You can see the "SW Initialization" message.

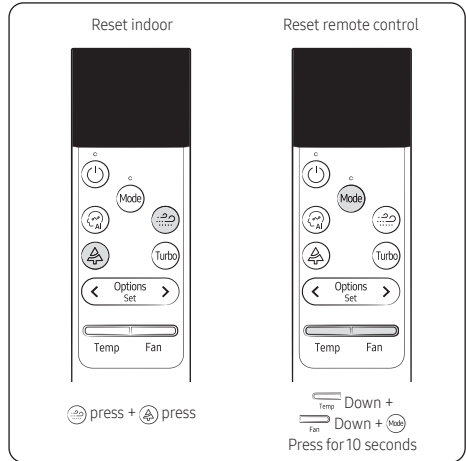

Setting the indoor unit addresses

Option No. for an indoor unit address: 0AXXXX-1XXXXX-2XXXXX-3XXXXX

Before installing an indoor unit, be sure to set an address for the indoor unit by taking the following steps:

- 1 Make sure that the power is supplied to the indoor unit. If the indoor unit is not plugged in, it must include a power supply.



- 2 Set an address for each indoor unit using the remote control, according to your air conditioning system plan, by referring to the following table and by following the steps in **Common steps for setting the addresses and options** on page 26.
 - The indoor unit addresses (main and RMC addresses) are set to 0A0000-100000-200000-300000 by default.
 - If indoor units and outdoor units match 1:1, you don't need to set the main address because it is automatically set by the outdoor unit.
 - If using an on or off controller, set the RMC address.

Option	SEG1		SEG2		SEG3		SEG4	SEG5		SEG6	
Function	Page		Mode		Setting main address		Reserved	Indoor unit number		Indoor unit number	
Indication and details	Indication	Details	Indication	Details	Indication	Details		Indication	Details	Indication	Details
	0		A		0	No main address		0 to 1	Tens digit	0 to 9	Units digit
					1	Main address setting mode					
Option	SEG7		SEG8		SEG9		SEG10	SEG11		SEG12	
Function	Page		Reserved		Setting RMC address		Reserved	Group channel (x16)		Group address	
Indication and details	Indication	Details			Indication	Details		Indication	Details	Indication	Details
	1				0	No RMC address		RMC1	0 to 2	RMC2	0 to F
			1	RMC address setting mode							

⚠ CAUTION

- The main address must be set to a value in the range 0 to 15. If you set other values, a communication error will occur.
- If any of SEG5 and SEG6 are set to a value in the range A to F, the main address of the indoor unit does not change.
- If SEG3 is set to 0, the indoor unit maintains the existing main address even if SEG6 is set to a new value.
- If SEG9 is set to 0, the indoor unit maintains the existing RMC address even if SEG11 and SET12 are set to new values.

Installation Procedure

Setting the installation options in a batch

Installation option No. for an installation options : 0XXXXX-1XXXXX-2XXXXX-3XXXXX

- 1 Make sure that the power is supplied to the indoor unit. If the indoor unit is not plugged in, it must include a power supply.

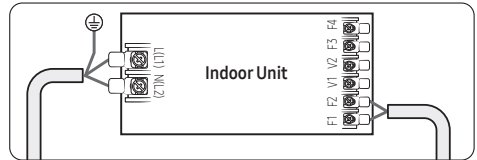

- 2 Set the installation options of indoor units, by referring to the following table and by following the steps in **Common steps for setting the addresses and options** on page 26.

- The installation options for indoor units are configured according to the table below by default.

Model	AC***DNNDCG
02 series installation option	020010-100001-200020-300000
05 series installation option	050020-100700-200000-300000

- The SEG20 option, Individual control with remote control, allows you to control multiple indoor units individually by using the remote control.

02 series installation option (Detailed)

Option No. 02XXXX-1XXXXX-2XXXXX-3XXXXX

Option	SEG1		SEG2		SEG3	SEG4		SEG5		SEG6		
Function	Page		Mode		Reserved	Use of external room temperature sensor / Minimizing fan operation when the thermostat is off		Central control		Compensation of the fan RPM		
Indication and details	Indication	Details	Indication	Details		Indication	Details		Indication	Details	Indication	Details
	0			2		Installation Option 1	Indication	Use of external room temperature sensor	Minimizing fan operation when the thermostat is off ¹⁾	0	Disuse	0
					0	Disuse	Disuse					
					1	Use	Disuse					
					2	Disuse	Use (Heating)					
					3	Use	Use (Heating)					
					4	Disuse	Use (Cooling)					
					5	Use	Use (Cooling)					
					6	Disuse	Use (Cooling/Heating)					
					7	Use	Use (Cooling/Heating)					
					8	Disuse	Use (Cooling Ultra low speed)					
					9	Use	Use (Cooling Ultra low speed)					
					A	Disuse	Use (Heating/Cooling Ultra low speed)	1	Use	1	Use	
					B	Use	Use (Heating/Cooling Ultra low speed)					

Option	SEG7		SEG8		SEG9	SEG10	SEG11	SEG12									
Function	Page		Use of drain pump & Emergency Stop ²⁾					Dew removal operation in WindFree mode/WindFree mode in Auto cleaning/Smart Comfort in Auto mode									
Indication and details	Indication	Details	Indication	Details		Reserved	Reserved	Reserved	Indication	Details							
				Drain pump	Emergency Stop					Dew removal operation in WindFree mode	WindFree mode in Auto cleaning	Smart Comfort in Auto mode					
	1		0 or 4	Disuse	Disuse				Use	0	Maintain blade	WindFree disuse	Smart Comfort use				
			1 or 5	Use						1	Open blade						
			2 or 6	Use with 3min delay						2	Maintain blade	WindFree use					
			3 or 7	Disuse						3	Open blade						
			8 or C	Disuse	4					Maintain blade	WindFree disuse	Smart Comfort disuse					
			9 or D	Use	5					Open blade							
			A or E	Use with 3min delay	6					Maintain blade	WindFree use						
			B or F	Disuse	7					Open blade							
-																	
Option	SEG13		SEG14		SEG15		SEG16	SEG17		SEG18							
Function	Page		Use of external control		Setting the output of external control			Buzzer control / Refrigerant detection sensor		Maximum filter usage time ⁴⁾							
Indication and details	Indication	Details	Indication	Details		Indication	Details	Indication	Details		Indication	Details					
				Buzzer	Refrigerant detection sensor				Indication	Details							
	2		0	Disuse	Sub, Existing control	0	Thermo on	Reserved	0	Use	Disuse	2	1000 hours				
			1	On/Off		1	Operation on										
			2	Off		2	External heater use (Fan On when the heater is running) Emergency heater disuse										
			3	Window On/Off	Main, Existing control	3	External heater use (Fan OFF when the heater is running) Emergency heater disuse		1	Disuse	Disuse						
			4	Disuse		Sub, Reverse control	4							External heater use (Fan On when the heater is running, Fan off only in case of Defrost) Emergency heater disuse	2	Use	Use
			5	On/Off			5							External heater use(Fan On when the heater is running) Emergency heater use			
			6	Off	6		External heater use (Fan OFF when the heater is running) Emergency heater use		3	Disuse	Use						
			7	Window On/Off	Main, Reverse control	7	External heater use (Fan On when the heater is running, Fan off only in case of Defrost) Emergency heater use					6	2000 hours				
			8	Disuse		6	2000 hours										
			9	On/Off													
			A	Off													
			B	Window On/Off													
			C	Disuse													
D	On/Off																
E	Off																
F	Window On/Off																

Installation Procedure

Option	SEG19		SEG20		SEG21		SEG22	
Function	Page		Individual control with remote control ⁵⁾		Heating setting compensation		Reserved	
Indication and details	Indication	Details	Indication	Details	Indication	Details		
	3			0 or 1	Indoor1	0		Disuse
				2	Indoor2	1		3,6°F (2°C)
				3	Indoor3	2		9°F (5°C)
			4	Indoor4				
Option	SEG23						SEG24	
Function	Setting the MDS Kit installation option ⁶⁾						Reserved	
Indication and details	Indication		Details					
	0		Disuse (Soft Off+Hard off)					
	Standard	1	Off after 20 min. (Soft Off+Hard off)					
		2	Off after 40 min. (Soft Off+Hard off)					
		3	Off after 80 min. (Soft Off+Hard off)					
	Premium	4	Off after 20 min. (Soft Off+Hard off)					
		5	Off after 40 min. (Soft Off+Hard off)					
		6	Off after 80 min. (Soft Off+Hard off)					
	Standard	7	Off after 20 min. (Soft Off only)					
		8	Off after 40 min. (Soft Off only)					
		9	Off after 80 min. (Soft Off only)					
	Premium	A	Off after 20 min. (Soft Off only)					
		B	Off after 40 min. (Soft Off only)					
C		Off after 80 min. (Soft Off only)						

- **1) SEG4**

By SEG4 setting, minimize fan operation when the thermostat is off.
 - Fan operates for 20 seconds at an interval of 5 minutes in heat mode.
 - Fan stops or operates Ultra low in Cooling when the thermostat is off.

- **2) SEG8**

Drain pump: The Drain pump option is automatically set to [Used with 3minute delay], even if you set it to [Disuse].

Emergency Stop: If you set Emergency Stop to [Use], it is not possible to use the ETO or On/Off Control feature through External Control (SEG14).

- **3) SEG11**

Compensation of the WindFree fan RPM option adjusts 20 rpm per 1 step.

- **4) SEG18**

If you set the Maximum filter usage time option to a value other than 2 and 6, it is automatically set to 2 (1000 hours).

- **5) SEG20**

If you set the Individual control with the remote control option to a value other than 0 to 4, it is automatically set to 0 (Indoor1)

- **6) SEG23**

Soft Off: After its final motion detection, the indoor unit turns off its operation at the indicated time in the table for the Installation Option. But it turns on again if the MDS detects motion.

Hard Off: Designated time after SOFT OFF, it cannot turn on automatically when it detects motion. Users should control the indoor unit with a remote control, etc.

05 series installation option (Detailed)

Option No. 05XXXX-1XXXX-2XXXX-3XXXX

SEG1		SEG2		SEG3		SEG4			SEG5	SEG6			
Page		Mode								Auxiliary heater offset temp. and time delay			
Indication	Details	Indication	Details							Details			
0		5	Installation Option 2	Reserved		Reserved			Reserved	0	No temperature offset	No delay	
										1	No temperature offset	10 minutes	
										2	No temperature offset	20 minutes	
										3	2.7°F (1.5°C)	No delay	
										4	2.7°F (1.5°C)	10 minutes	
										5	2.7°F (1.5°C)	20 minutes	
										6	5.4°F (3°C)	No delay	
										7	5.4°F (3°C)	10 minutes	
										8	5.4°F (3°C)	20 minutes	
										9	8.1°F (4.5°C)	No delay	
										A	8.1°F (4.5°C)	10 minutes	
										B	8.1°F (4.5°C)	20 minutes	
										C	10.8°F (6°C)	No delay	
										D	10.8°F (6°C)	10 minutes	
										E	10.8°F (6°C)	20 minutes	
SEG7		SEG8		SEG9		SEG10			SEG11	SEG12			
Page		Heater Lock out		Heat pump lock out		Bit 0 : Allow Fan control in auto mode Bit 1 : Onboarding Type (AP / BLE) Bit 2 : MDS UX Type (Integration / separation)							
Indication	Details	Indication	Details	Indication	Details	Indication	Details						
1	0	Disuse		0	Disuse	0	Not allow	Ap Onboarding	Integration UX	0	Reserved		
	1	65 °F (18.3 °C)		1	45 °F (7.2 °C)	1	allow	Ap Onboarding	Integration UX				
	2	60 °F (15.6 °C)		2	40 °F (4.4 °C)								
	3	55 °F (12.8 °C)		3	35 °F (1.7 °C)	2	Not allow	BLE Onboarding	Integration UX				
	4	50 °F (10.0 °C)		4	30 °F (-1.1 °C)								
	5	45 °F (7.2 °C)		5	25 °F (-3.9 °C)	3	allow	BLE Onboarding	Integration UX				
	6	40 °F (4.4 °C)		6	20 °F (-6.7 °C)								
	7	35 °F (1.7 °C)		7	15 °F (-9.4 °C)	4	Not allow	Ap Onboarding	Separation UX				
	8	30 °F (-1.1 °C)		8	10 °F (-12.2 °C)								
	9	25 °F (-3.9 °C)		9	5 °F (-15 °C)	5	allow	Ap Onboarding	Separation UX				
	A	20 °F (-6.7 °C)		A	0 °F (-17.8 °C)								
	B	15 °F (-9.4 °C)		B	-5 °F (-20.6 °C)	6	Not allow	BLE Onboarding	Separation UX				
	C	10 °F (-12.2 °C)		C	-10 °F (-23 °C)								
	D	5 °F (-15 °C)		D	-15 °F (-26 °C)	7	allow	BLE Onboarding	Separation UX				
E	0 °F (-17.8 °C)		E	-20 °F (-29 °C)									

Installation Procedure

SEG13	SEG14	SEG15	SEG16	SEG17	SEG18
Page	Reserved	Reserved	Reserved	Reserved	Reserved
Indication Details					
2					
SEG19	SEG20	SEG21	SEG22	SEG23	SEG24
Page	Reserved	Reserved	Reserved	Reserved	Reserved
Indication Details					
3					

Changing the addresses and options individually

When you want to change the value of a specific option, refer to the following table and follow the steps in **Common steps for setting the addresses and options** on page 26.

Option	SEG1		SEG2		SEG3		SEG4		SEG5		SEG6	
Function	Page		Mode		Option mode to change		Tens position of the option number		Units position of the option number		New value	
Indication and details	Indication	Details	Indication	Details	Indication	Details	Indication	Details	Indication	Details	Indication	Details
		0		D		Option type	0 to F	Tens position value	0 to 9	Units position value	0 to 9	New value

Example: Changing the Buzzer control (SEG17) option of the installation options to 1 disuse.

Option	SEG1	SEG2	SEG3	SEG4	SEG5	SEG6
Function	Page	Mode	Option mode to change	Tens position of the option number	Units position of the option number	New value
Indication	0	D	2	1	7	1

Installing external outputs

- An external output signal occurs if the R-32 sensor in the indoor unit detects a refrigerant leak, or the sensor has a malfunction or short circuit.
- Based on this signal, safety measures required for the indoor unit, such as ventilation system activation and alarm activation, can be taken.
- MIM-B14U (External Contact Control Module) can be used to link the GAS LEAK output.

For controlling AC LAMP (On/Off)

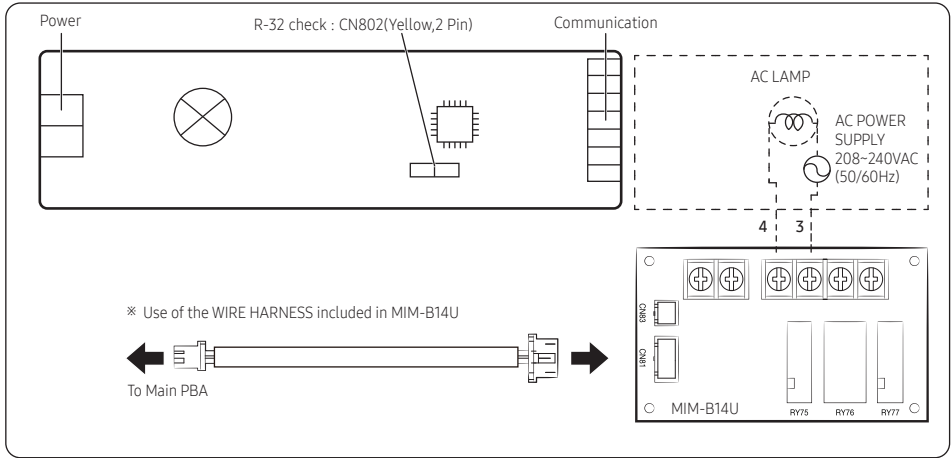



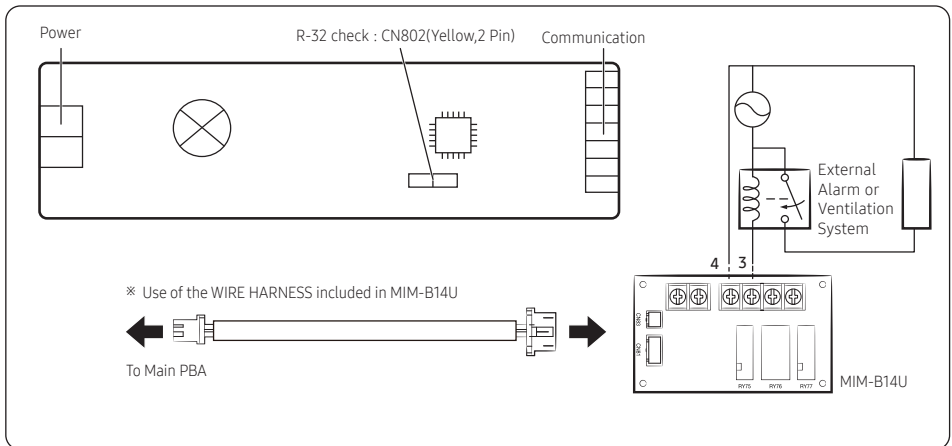



























For controlling EXTERNAL ALARM or VENTILATION SYSTEM (On/Off)



NOTE

- The MIM-B14U can be connected to the required load on connectors 3 and 4.
- The load is AC (208-230), AC 2.25A max.
- When an error occurs due to a gas leak or R-32 sensor error, 3 and 4 are in a short state (the relay operates).

Troubleshooting

Abnormal conditions	Error code	LED lamp display			
		Operation	Defrost	Timer	Filter
					
Power reset	-		X	X	X
Error of temperature sensor in the indoor unit (Open/Short)	E121	X		X	X
1. Eva-In Sensor Error (Open/short)	E122				
2. Eva-out Sensor Error (Open/short)	E123			X	X
3. Discharge sensor error (Open/short)	E126				
Error of fan motor in the indoor unit	E154	X	X		X
1. Error of the outdoor temperature sensor(Open/short)	E221				
2. Error of the condenser temperature sensor	E237		X		X
3. Error of the discharge temperature sensor	E251				
1. No communication between indoor unit and outdoor unit. (Communication error for more than 2 minutes)	E101				
2. Indoor unit receiving the communication error from outdoor unit	E102				
3. Outdoor unit tracking 3 minutes error	E202	X			X
4. Communication error after tracking due to unmatching number of installed units	E201				
5. Error due to repeated communication address	E108				
1. Indoor operation stop due to unconfirmed error on outdoor unit	-				
2. Error due to opened EEV (2nd detection)	E151				
3. 2nd detection of high temperature cond	E450				
4. 2nd detection of high temperature discharge	E416				
5. Error of reverse phase	E425				
6. Compressor down due to 6th detection of freezing	E403				
7. Error indicating a short-circuit, open-circuit or fault signal in the refrigerant leak sensor	E116	X			
8. Error indicating a primary refrigerant leak detection error	E696				
9. Error indicating a secondary refrigerant leak detected	E697				
10. Error indicating a malfunction of the refrigerant leak sensor	E698				
11. R-32 detection sensor replacement alarm	E699				
12. R-32 detection sensor unavailable alarm	E700				
13. Error indicating another indoor unit that shares the outdoor unit detects the R-32 refrigerant.	E797				
1. Detection of the float switch	E153				
2. Emergency alarm system on (Emergency Stop)	E665	X	X		
1. EEPROM error	E162				
2. EEPROM option error	E163				
MDS (Motion Detecting Sensor) Error	-		X	X	
Outdoor valve clogging error	E422		X		
Error due to connecting outdoor units that do not support the WindFree function	-			X	

● : On, ◐ : Flickering, X : Off

- If you turn off the air conditioner when the LED is flickering, the LED is also turned off.

SAMSUNG