

# Air conditioner

# User & Installation manual

---

## WindFree 1-Way Cassette Panel

---

- Thank you for purchasing this Samsung air conditioner.
- Before operating this unit, please read this manual carefully and retain it for future reference.

# Installing the WindFree 1-Way Cassette Panel

**⚠ WARNING:** Cancer and Reproductive Harm - [www.P65Warnings.ca.gov](http://www.P65Warnings.ca.gov).

This device complies with Industry Canada license exempt RSS standard(s). Operation is subject to the following two conditions: (1) this device may not cause harmful interference and (2) this device must accept any interference received, including interference that may cause undesired operation. This Class B digital apparatus complies with Canadian ICES-003.

This equipment complies with FCC and IC RSS-102 radiation exposure limits set forth for an uncontrolled environment. This equipment should be installed and operated with a minimum distance of 23.62 inches (600mm) between the radiator & your body. Any changes or modifications not expressly approved by the manufacturer could void the manufacturer's warranty.

This device and its antenna(s) must not be co-located or operated in conjunction with any other antenna or transmitter.

**If the WindFree function is not visible on the upper-level controller after connecting the WindFree panel:**

- Check if the software of the upper-level controller is the latest version.
  - If the software is not the latest version, update to the latest version.
  - If the software of the upper-level controller is the latest version but the WindFree function is not visible on it, perform tracking again on the upper-level controller or reset its power.
- ※ Upper-level controller: DMS, Touch Centralized Controller or another device

Item	Screw	Tightening torque (lbf-ft(N-m))
Shape	M4 L 0.98 inch (25 mm)	0.9~1.3 lbf-ft (1.2~1.8) (N-m)

(1 N·m = 10 kgf·cm)

**⚠ CAUTION**

- After installing the product, explain to the user how to use the air conditioner.

## Installing the panel

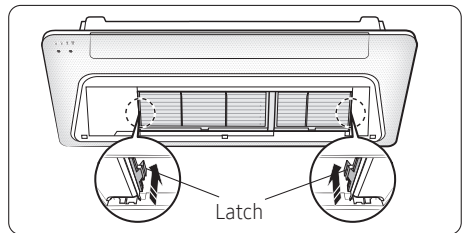

**⚠ CAUTION**

- Handle the panel carefully.
  - Do not lean the panel against a wall or place it on a protruding object. Failing to do so may damage the surface of the panel.
  - Be careful when installing the air inlet panel by hand. You may get hurt.
- 1** Fix the panel by engaging the latches at both sides onto the grooves on both sides of the indoor unit.



- 2** Open the screw cover on the air outlet, insert and fasten the panel fixing screws. If the screws are not fastened completely, it may produce a gap between the indoor unit and the panel, resulting in condensation.

## Accessories

Item	M4x25 screw	User & Installation manual (1)
Shape	 PC1MWFMUNW : (5) PC1NWFMUNW : (6) PC1BWFMUNW : (7)	

### PC1MWFUNW (A Type)

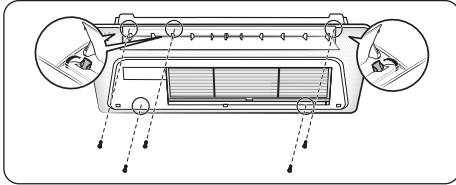

### PC1NWFUNW (B Type)

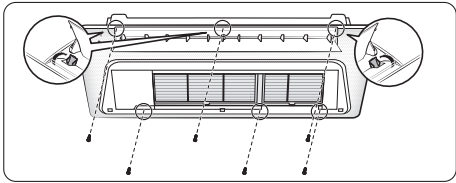

### PC1BWFUNW (C Type)

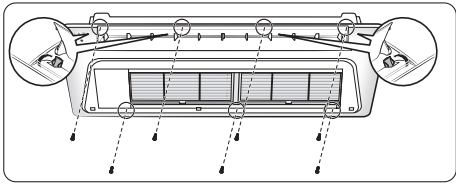

- 3 Press the handle of the air filter and pull it out.
- The handle appearance of the air filter may differ, depending on the model. Refer to the image.

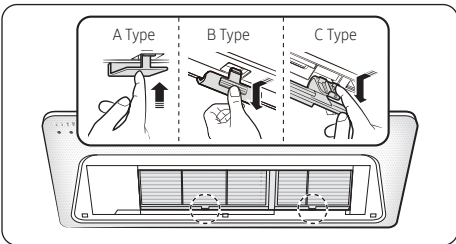

- 4 Perform wiring between the indoor unit and the panel:
- Unfasten the 3 screws from the electrical part, and then remove the electrical part.

- Connect the connectors on the panel to the connectors on the indoor unit PCB:
  - Connect the connectors of the swing motor, remote control sensor, and humidity sensor, Wi-Fi module on the panel to their respective connectors on the indoor unit PCB.
  - Make sure that the colors of the connectors match each other.
- Reassemble the electrical part.
- Close the air filter.

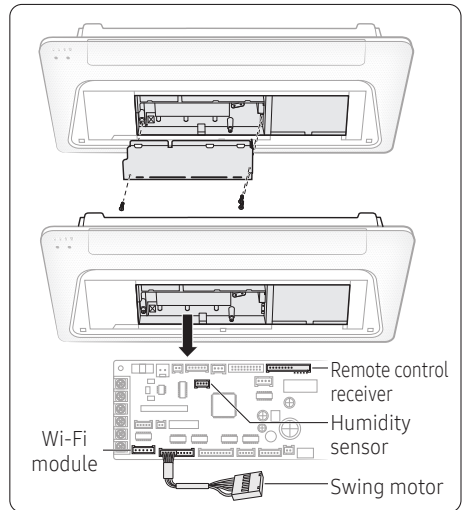

### NOTE

- If any connector is not connected or is connected to a different color connector, both the air conditioner and the remote control will not operate.
- 5 Check whether the panel is firmly fixed to the indoor unit.
- Make sure that the screws are fastened tightly until there is no gap between the ceiling and the panel, and that the panel is installed in parallel with the ceiling and the ceiling joints:
    - If there is a gap between the ceiling and the panel, adjust the height of the indoor unit.

# Installing the WindFree 1-Way Cassette Panel

## ⚠ CAUTION

- If the panel is installed incorrectly onto the cassette, air may leak out.

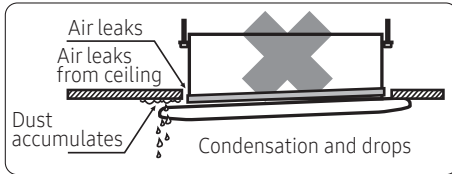
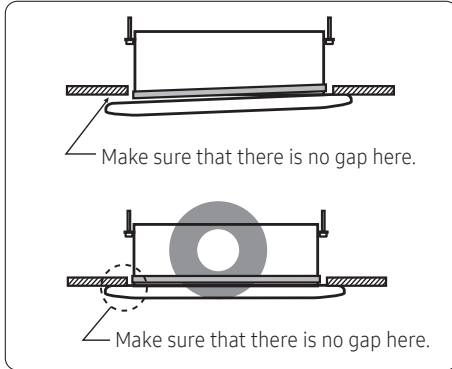

Incomplete installation (fastening) produces the problems as shown in the figure. Be sure to check again after the installation.

- When installing the panel, if there are any gaps between the panel and the indoor unit due to incomplete installation (fastening), air and condensation water may leak into the room. Be sure to remove gaps by using the indoor unit installation gauges (on the pattern sheet for installation).
  - For detailed specifications, refer to the installation manual for the product.

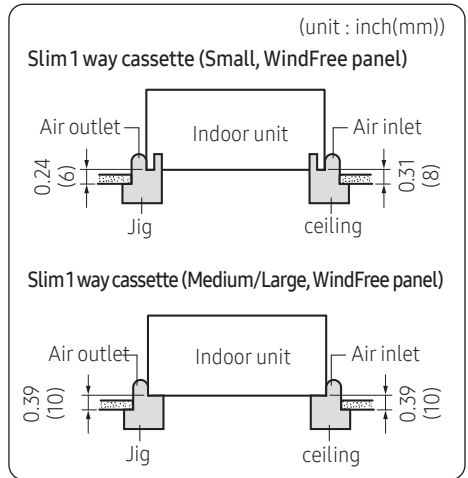

- 6 Connect the grill.
  - Hook the 2 panel safety hooks onto both sides of the grill.
  - Push the [PUSH] sign to fix the grill.

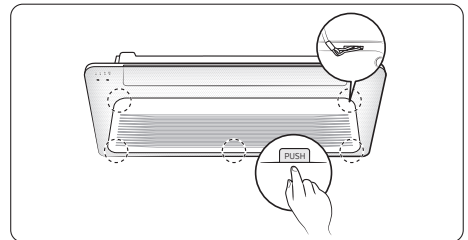

## 📖 NOTE

- Before working on the grill, be sure to hook the panel safety hooks onto both sides of the grill to prevent it from falling during work.

# SmartThings app

To use the SmartThings app, connect the product to the network in the sequence described below. The images shown may differ depending on your smartphone model, OS version and manufacturer. You need to set up the Wi-Fi access point only when connecting the product to a Wi-Fi network. Once the product is connected, you can use the SmartThings app via Wi-Fi, 3G, LTE, 5G or more wireless networks.

## 1 Checking the power connections

Check if the power is connected to the product and the access point.

## 2 Setting up and connecting to a Wi-Fi access point using your smartphone

### 1 To connect the product to a Wi-Fi network, turn on Wi-Fi at "Settings > Wi-Fi", and then select the access point to connect to

- Only alphanumeric characters are supported for wireless access point names (SSIDs). If an SSID has a special character, rename it before connecting to it.
- This product supports only Wi-Fi 2.4 GHz.



### 2 Turning off "Switch to mobile data" at "Settings > Wi-Fi" on your Smartphone

- If "Switch to mobile data" or "Adaptive Wi-Fi" is turned on, you cannot connect to the network. Be sure to turn off these functions before connecting to the network.



#### NOTE

- The setup may differ depending on your smartphone model, OS version and manufacturer.

## 3 Checking the Internet connectivity

- After connecting to Wi-Fi, check that your smartphone is connected to the Internet.

#### NOTE

- A firewall may prevent your smartphone from connecting to the Internet. Contact your Internet service provider for troubleshooting.

## 3 Downloading the SmartThings app and registering your Samsung account

### 1 Downloading the SmartThings app

- Search for "SmartThings" on Play Store or App Store, and download the SmartThings app to your smartphone.
- If the SmartThings app is already installed on your smartphone, update it to the latest version.

#### NOTE

- The SmartThings app supports Android OS 7.0 or later (with at least 2 GB RAM) and iOS 12.0 or later. The app is optimized for iPhone 6s or later and Samsung smartphones (Galaxy S and Note series). The updates of the SmartThings app or the functions supported by it may be discontinued for the previously supported OS versions due to reasons such as usability and security.
- The SmartThings app may change without prior notice to improve product usability and performance.

# SmartThings app

## 2 Registering your Samsung account

- A Samsung account is required to use the SmartThings app. To create your Samsung account and log in to your account, follow the instructions displayed on the SmartThings app. You do not need to install an additional app.

### NOTE

- If you already have a Samsung account, log in to the account. If you have a smartphone that is a Samsung device and you have a Samsung account, your smartphone is automatically logged in to your account.
- If you log in from a smartphone produced for another country, you need to log in with its country code when you create your Samsung account, and the SmartThings app may not be used on some smartphones.

## 4 Connecting the SmartThings app to your product

### 1 Selecting the product to connect to

- 1) Start the SmartThings app about one minute after turning on the product to connect to.
- 2) After the SmartThings app is started, select 'ADD NOW' when a pop-up window saying that a product to connect to is found appears.

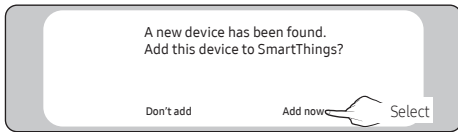

- 3) If the pop-up window does not appear, select "+", and then "Add Device".

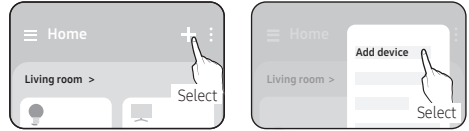

You can add a product you want to connect to by selecting it manually or by selecting "Scan nearby".

- Select manually: Samsung devices > Air conditioner
- Scan: Scan nearby > Air conditioner

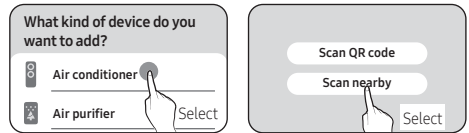

### 2 Connecting the SmartThings app to your product

- Follow the instructions displayed on the SmartThings app to connect to your product.
- For information on how to use the SmartThings app, select the How To menu on the app.

### NOTE

- If any pop-up window appears on the top of the smartphone while connecting to your product, do not select it.
- If a pop-up window saying that the device is already registered appears during connecting to your product, get permission using "REQUEST PERMISSION" from a user already connected to the product, or create a new account using "REGISTER MY ACCOUNT" to independently connect to the product.
- If a Samsung account-related country error occurs while connecting to your product, log out of your current Samsung account, log in to your previous Samsung account, and then delete all devices that have been connected previously. Then, log in to your current Samsung account again, and configure the settings.

- 
- If a failure message appears while adding a device, see "Setting up and connecting to a Wi-Fi access point using your smartphone" on page 5. The connection may fail temporarily due to an installation location problem of the access point or other problems.
  - If a message appears on the SmartThings app, follow its instructions.

 **NOTE**

- For the security protocols for wireless/wired access points, WPA-PSK and WPA2-PSK are recommended. For the authentication methods, AES is recommended. New Wi-Fi authentication specifications and Wi-Fi non-standard authentication methods are not supported.
- The product supports the IEEE802.11 b/g/n (2.4 GHz) communication protocol. (Samsung recommends IEEE802.11n.)
- If your Internet service provider has permanently registered the MAC address (a unique identification number) of your PC or modem, you may not be able to connect your product to the Internet. Contact your Internet service provider and ask how to connect devices other than your PC (such as an air conditioner and an air purifier) to the Internet.

---

## Open Source Announcement

---

The software included in this product contains open source software.

The following URL [http://opensource.samsung.com/opensource/SMART\\_TP1\\_0/seq/0](http://opensource.samsung.com/opensource/SMART_TP1_0/seq/0) leads to open source license information as related to this product.



# Troubleshooting

Check the following before requesting a service from the Service Center

Symptom		Measure
The installed SmartThings app cannot access the air conditioner.		<ul style="list-style-type: none"> <li>Make sure you have connected the air conditioner to a wireless router.</li> </ul>
I cannot log in with my Samsung account.		<ul style="list-style-type: none"> <li>Try recovering your ID and password from the Samsung account page.</li> </ul>
Adding device(s)	A failure message appears while adding devices.	<ul style="list-style-type: none"> <li>This may fail temporarily due to the distance from the router or some interferences. Try again later.</li> </ul>
	While adding the device, the progress stops at 0%-1% and a message appears saying that adding the device has failed.	<ul style="list-style-type: none"> <li>You cannot add any device without deleting it once the device has already been added to the SmartThings app. To add the connected device again, first remove it and then proceed with the process.</li> </ul>
	While adding the device, the progress is stuck at 99% and a message appears saying that adding the device has failed.	<ul style="list-style-type: none"> <li>If you are using a Samsung smartphone, the server may not be connected temporarily. Restart the SmartThings app and then try adding the device again.</li> <li>If your phone is not a Samsung product, check that you have entered a wrong Wi-Fi password. Try adding devices again.</li> </ul>
	The app displays an authorization failure before pressing the user agreement button.	<ul style="list-style-type: none"> <li>Check if a Wi-Fi Kit Single is already connected from the SmartThings app. When there are devices added, first remove them and try again.</li> </ul>
	The app displays an authorization failure on the user agreement screen.	<ul style="list-style-type: none"> <li>Make sure to press the [Power] button within 2 minutes after the screen appears. Try adding devices again.</li> </ul>
	The screen requests to initialize the user account.	<ul style="list-style-type: none"> <li>This happens when the user has already added devices. Follow the instructions provided in the SmartThings app.</li> </ul>
	After adding a device, the SmartThings app displays the disconnection event.	

# Regulatory Notice

---

## FCC Notice

---

### **FCC CAUTION:**

Any changes or modifications not expressly approved by the party responsible for compliance could void the user's authority to operate the equipment.

This appliance contains the transmitter module.

This device complies with Part 15 of FCC Rules. Operation is Subject to the following two conditions:

- (1) This device may not cause harmful interference, and
- (2) This device must accept any interference received including interference that cause undesired operation.

For products available in the US and Canadian markets, only channels 1~11 are available.

You cannot select other channels.

### **FCC STATEMENT:**

This equipment has been tested and found to comply within the limits for a Class B digital device, pursuant to part 15 of the FCC Rules. These limits are designed to provide reasonable protection against harmful interference in a residential installation.

This equipment generates, uses, and can radiate radio frequency energy and, if not installed and used in accordance with the instructions, may cause harmful interference to radio communications. However, there is no guarantee that interference will not occur in a particular installation. If this equipment does cause harmful interference to radio or television reception, which can be determined by turning the equipment off and on, the user is encouraged to try to correct the interference by one or more of the following measures:

- Reorient or relocate the receiving antenna
- Increase the separation between the equipment and receiver
- Connect the equipment to an outlet that is on a different circuit than the receiver.
- Consult the dealer or an experienced radio/TV technician for help.

### **FCC RADIATION EXPOSURE STATEMENT:**

This equipment complies with FCC radiation exposure limits set forth for an uncontrolled environment.

This equipment should be installed and operated so there is at least 8 inches (20 cm) between the radiator and your body. This device and its antennas must not be co-located or operated in conjunction with any other antenna or transmitter except in accordance with FCC multi-transmitter product procedures.

# Regulatory Notice

---

## IC Notice

---

This appliance contains the transmitter module.

The term "IC" before the radio certification number only signifies that Industry Canada technical specifications were met. Operation is subject to the following two conditions : (1) this device may not cause interference, and (2) this device must accept any interference, including interference that may cause undesired operation of the device.

This Class B digital apparatus complies with Canadian ICES-003.

For products available in the US and Canadian markets, only channels 1~11 are available.

You cannot select other channels.

## IC RADIATION EXPOSURE STATEMENT:

This equipment complies with IC RSS-102 radiation exposure limits set forth for an uncontrolled environment. This equipment should be installed and operated so there is at least 8 inches (20 cm) between the radiator and your body. This device and its antennas must not be co-located or operated in conjunction with any other antenna or transmitter except in accordance with FCC multi-transmitter product procedures.

**SAVE THESE INSTRUCTIONS**

# Memo

---

**SAMSUNG**