

# Air conditioner

# Installation manual

---

AJ\*\*\*DNADCG

---

- Thank you for purchasing this Samsung air conditioner.
- Before installing this unit, please read this installation manual carefully and retain it for future reference.

Original instructions

**SAMSUNG**

# Contents

---

<b>Safety Information</b>	<b>3</b>
Safety Information	3
<b>Installation</b>	<b>9</b>
Preparation	9
Step 1-1 Typical installation overview	9
Step 1-2 Choosing the installation location	10
Step 1-3 Unpacking	13
Step 1-4 Preparing materials and tools	14
<b>Indoor Unit Installation</b>	<b>16</b>
Step 2-1 Attaching the mounting bracket to the wall	16
Step 2-2 Drilling the wall penetration	16
Step 2-3 Connecting the refrigerant pipes	17
Step 2-4 Connecting the power and communication cables	18
Step 2-5 Connecting the drain hose	19
Step 2-6 Taping the pipes, cables, and drain hose	20
<b>Installation Inspection and Testing</b>	<b>21</b>
Step 3-1 Performing a drain leak test	21
Step 3-2 Performing pressure tests using nitrogen	21
Step 3-3 Evacuating the system	22
Step 3-4 Performing final checks and trial operation	24
Setting the installation options	25
<b>Maintenance Procedures</b>	<b>36</b>
Sub PCB installation (optional accessory)	37

# Safety Information

## **WARNING: Read This Manual**

- Read and follow all safety information and instructions before installation, use, or maintenance of this appliance. Incorrect installation, use, or maintenance of this appliance can result in death, serious injury, or property damage. Keep these instructions with this appliance. This manual is subject to change. For the latest version, visit [www.samsunghvac.com](http://www.samsunghvac.com).

This manual explains how to install a split-system, ductless unit using matched indoor and outdoor units. The manufacturer shall not be responsible for damages arising from the use of non-compatible units.

For information on compatible units and unit specifications, refer to the submittal document for the applicable model, available at [www.samsunghvac.com](http://www.samsunghvac.com).

Because the instructions in this manual cover various models, the characteristics of your air conditioner may differ slightly from those described. If you have any questions, please contact your dealer or visit [www.samsunghvac.com](http://www.samsunghvac.com).

This device complies with Industry Canada license exempt RSS standard(s). Operation is subject to the following two conditions: (1) this device may not cause harmful interference and (2) this device must accept any interference received, including interference that may cause undesired operation. This Class B digital apparatus complies with Canadian ICES-003.

This equipment complies with FCC and IC RSS-102 radiation exposure limits set forth for an uncontrolled environment. This equipment should be installed and operated with minimum distance 23.62 inch (600mm) between the radiator & your body. Any changes or modifications not expressly approved by the manufacturer could void manufacturer's warranty.

### ENERGY STAR qualified systems only

Proper sizing and installation of equipment is critical to achieve optimal performance. Split system air conditioners and heat pumps (excluding ductless systems) must be matched with appropriate coil components to meet ENERGY STAR criteria. Ask your contractor for details or visit [www.energystar.gov](http://www.energystar.gov).





# Safety Information

## Notices and notes

To make you aware of safety messages and highlighted information, we use the following notices and notes throughout this manual:

### **WARNING**

Hazards or unsafe practices that may result in severe personal injury or death.

### **CAUTION**







Hazards or unsafe practices that may result in minor personal injury or property damage.

### **IMPORTANT**

Information of special interest

### **NOTE**

Supplementary information that may be useful

Symbol	Meaning
	Flammable gas
	Warning: flammable materials
	Refrigerant safety group
	Read installation manual
	Refer to installation manual
	Read service manual

## FOR GENERAL

### California Proposition 65 Warning (US)

 **WARNING:** Cancer and Reproductive Harm - [www.P65Warnings.ca.gov](http://www.P65Warnings.ca.gov).

This appliance is not intended for use by persons (including children) with reduced physical, sensory, or mental capabilities, or lack of experience and knowledge unless they have been given supervision or instruction concerning the use of the appliance by a person responsible for their safety.

### **WARNING**

The installation and testing of this appliance must be performed by a qualified technician.

- The instructions in this manual are not intended as a substitute for proper training or adequate experience in the safe installation of the appliance.

Work shall be undertaken under a controlled procedure to minimize the risk of flammable gas or vapor being present while the work is being performed.

This unit is a PARTIAL UNIT AIR CONDITIONER, complying with PARTIAL UNIT requirements of this Standard. It must only be connected to other units that have been confirmed as complying with corresponding PARTIAL UNIT requirements of this Standard, UL 60335-2-40/CSA C22.2 No. 60335-2-40, or UL1995/CSA C22.2 No 236.

### General information

- All pipe work including piping material, pipe routing, and installation shall include protection from physical damage in operation and service and comply with national and local codes and standards, such as ASHRAE 15, ASHRAE 15.2, IAPMO Uniform Mechanical Code, ICC International Mechanical Code, or CSA B52. Any field joints shall be accessible for inspection before being covered or enclosed.
- The air conditioner should be used only for the applications for which it has been designed: the indoor unit is not suitable to be installed in areas used for laundry.
- Wear protective equipment (such as safety gloves, goggles, and headgear) during installation and maintenance work. Installation/repair technicians may be injured if improper protective equipment is worn.
- Do not use means to accelerate the defrost operation or to clean, other than those recommended by Samsung.
- Do not pierce or burn.
- Be aware that refrigerants may not contain an odor.





- This manual explains how to install an indoor unit with a split system with two Samsung units. The use of other types of units with different control systems may damage the units and invalidate the warranty. The manufacturer shall not be responsible for damages arising from the use of non compliant units.
- This product is pre-charged with mildly flammable gas classified as A2L by ASHRAE. The following precautions and instruction manuals must be followed during installation, operation, servicing and decommissioning of the product.
- All national and local regulations shall be observed at all times.
- All field piping and joints shall be pressure tested with an inert gas according to prevalent industry standards before refrigerant charging and system commissioning.
- Where additional field charging is required. The installer shall write with a permanent marker the field charge added on the ODU label provided, such that the Total Charge = Factory 'Pre-charge' + field charge.
- For ducted systems, any auxiliary systems that are potential ignition sources shall not be installed in the duct work. Examples of ignition sources are hot surfaces with temperatures exceeding 700°C and electric switching devices.
- Any auxiliary device installed must be approved by Samsung and must be suitable for operating with the refrigerant marked on the label.
- For mechanical ventilation the lower edge of the air extraction opening shall not be more than 100mm above the floor. The exhaust location outside the building must be at least 3 m away from the building opening and mechanical air intake openings.
- Non-ducted systems may be installed in areas such as false ceilings not being used as return air plenum if the conditioned air does not mix with the air in the false ceilings.
- For ducted appliances false ceilings or drop ceilings may be used as return air plenum if a refrigerant leak detection system is provided in the system and any external connections are also provided with a sensor immediately below the return air plenum duct joint.
- Installation, servicing, and any type of maintenance or repair must be performed by certified personnel who are competent to carry out such activity following national and local regulations.

### General information on Servicing

- All maintenance staff and others working in the local area shall be instructed on the nature of the work being performed and instructed to follow all instructions provided by Samsung, national and local authorities.
- The area shall be checked with an approved refrigerant detector before and during any work on the system.
- Have a dry CO<sub>2</sub> fire extinguisher adjacent to the charging area and workspace.

The following checks shall be applied to installations and maintenance operations.

- The actual total refrigerant charge is in accordance with the room size in accordance with Table 1.

- The ventilation machinery and outlets are operating adequately and are not obstructed.
- Markings on the equipment are visible and legible.
- Refrigerant pipes or components are installed in a position where they are unlikely to be exposed to any substance that may corrode refrigerant containing components.

Initial checks of electrical devices shall include the following.

- That capacitors are discharged safely to avoid sparking.
- That no live electrical components and wiring are exposed while charging, recovering or purging the system.
- That there is continuity to earth bonding.
- Check that cabling is not worn, corroded or damaged in any manner.
- The service personnel shall not use any ignition sources in a manner that it may lead to the risk of fire or explosion.

### Installation of the product

- The units must be installed in compliance with the clearances indicated in the installation manual to ensure either accessibility from both sides or ability to perform routine maintenance and repairs. The units' components must be accessible and serviceable in conditions of complete safety. For this reason, where it is not observed as indicated into the Installation Manual, the cost necessary to reach and repair the unit (safely as required by local regulations) with slings, trucks, scaffolding or any other means of elevation won't be considered in-warranty during any applicable labor warranty period.
- The outdoor unit shall be installed in an open space that is always ventilated.
- Please adhere to the local gas regulations.
- To handle, purge, and dispose the refrigerant, or to break into the refrigerant circuit, the technician should have a certificate from an industry-accredited authority.
- The installed refrigerant pipes should be kept to a minimum (do not install additional, unnecessary refrigerant pipe).
- Do not install the indoor unit in the following areas:
  - Area filled with minerals, splashed oil, or steam. It will deteriorate plastic parts, causing failure or leakage.
  - Area that is close to heat sources.
  - Area that produces substances such as sulfuric gas, chlorine gas, acid, and alkali. It may cause corrosion of the piping and brazed joints.
  - Area that can cause leakage of combustible gas and suspension of carbon fibers, flammable dust, or volatile flammables.
  - Area where refrigerant leaks and settles.
  - Area where animals may urinate on the product. Ammonia may be generated.
- Do not use the indoor unit for the preservation of food items, plants, equipment, and art works. This may cause deterioration of their quality.





# Safety Information

- Non-duct connected appliances containing A2L refrigerants with the supply and return air openings in the conditioned space may be installed in open areas such as false ceilings not being used as return air plenums, if the conditioned air does not directly communicate with the air within the false ceiling.
- Do not install the indoor unit if it has any drainage problem.
- Because your air conditioner contains R-32 refrigerant, make sure that it is installed, operated, and stored in a room whose floor area is larger than the minimum required floor area specified in the following table:

<Table 1>

m (lb)	Minimum Room Area (ft <sup>2</sup> )				
	Reference Height h0 (ft.)				
	6	7	8	9	10
4.05	- no room area restrictions -				
4.01	71	60	52	47	42
4.51	80	67	59	52	47
5.01	89	75	66	58	52
5.51	98	82	72	64	58
6.01	107	90	79	70	63
6.51	115	97	85	76	68
7.01	124	105	92	82	73
7.51	133	112	98	87	79
8.01	142	120	105	93	84

- $m$  : Total refrigerant charge in the system
- Calculated in accordance with UL 60335-2-40 Annex GG
- **IMPORTANT:** It's mandatory to either follow the table above or follow the federal, state, and/or local regulations regarding the minimum room area allowed for the total refrigerant charge in the system.
- The actual refrigerant charge shall be per room size within which the refrigerant-containing parts are installed.
- Ventilation machinery and outlets shall be operational and not obstructed.
- Markings to the equipment shall continue to be visible and legible. Markings and signs that are illegible shall be corrected.
- Refrigerating pipe or components shall be installed in a position where they are unlikely to be exposed to any substance that may corrode refrigerant containing components, unless the components are constructed of materials that are inherently resistant to being corroded or are suitably protected against being so corroded.

## Installation of the outdoor unit

- While in installation or relocation of the product, do not mix the refrigerant with other gases including air or unspecified refrigerant. Failure to do so may cause pressure increase and result in rupture or injury.

- Do not cut or burn the refrigerant container or piping.
- Use clean parts such as manifold gauge, vacuum pump, and charging hose for the refrigerant.
- Installation must be carried out by qualified personnel for handling the refrigerant. Additionally, reference local and national regulations and laws.
- Be careful not to let foreign substances (lubricating oil, refrigerant, water, etc.) enter the piping. The application of oil or refrigerant deteriorates the piping which can result in drain leakage. For storage, securely seal their openings.
- When mechanical ventilation is required, ventilation openings shall be kept clear of obstruction.
- For disposal of the product, follow the local laws and regulations.
- Do not work in a confined place.
- The work area shall be secured to only allow access by the technician(s).
- The refrigerant piping shall be installed in a position where there are no substances that may result in corrosion.
- The following checks shall be performed for installation:
  - The charging amount depends on the room size.
  - The ventilation devices and outlets are operating normally and are not obstructed.
  - Markings and signs on the equipment shall be visible and legible.
- Upon leakage of the refrigerant, ventilate the room. When the leaked refrigerant is exposed to flame, it may cause the generation of toxic gases.
- Make sure that the work area is safe from flammable substances.
- To purge air in the refrigerant pipes, be sure to use a vacuum pump.
- Note that the refrigerant has no odor.
- The units are not explosion proof so they must be installed with no risk of explosion.
- This product contains fluorinated gases that contribute to the global greenhouse effect. Accordingly, do not vent gases into the atmosphere.
- Models that use R-32 refrigerant have a different thread diameter for the charging port to prevent charging failure. Therefore, check its diameter (0.5 inch) in advance.
- Servicing shall be performed as recommended by the manufacturer. In case other skilled persons are joined for servicing, it shall be carried out under the supervision of the person who is competent in handling flammable refrigerants.
- For servicing the units containing flammable refrigerants, safety checks are required to minimize the risk of ignition.
- Servicing shall be performed following the controlled procedure to minimize the risk of flammable refrigerants or gases.
- Do not install where there is a risk of combustible gas leakage.





- Do not place near heat sources.
- Be cautious not to generate a spark as follows:
  - Do not remove fuses with power on.
- If the indoor unit is not R-32 compatible, an error signal appears and the unit will not operate.
- After installation, check for leakage. Toxic gas may be generated if it comes into contact with an ignition source such as a fan heater, stove, or propane cylinders. Make sure that only refrigerant recovery cylinders are used.

## Electrical repair safety measures

---

- All electrical components used or replaced must be to Samsung's specifications.
- If a fault exists that could compromise safety, then no electrical supply shall be connected to the circuit until it is satisfactorily dealt with.
- Sealed electrical components and intrinsically safe components shall be replaced and not repaired.
- Cabling should be protected from excessive vibration, pressure, sharp edges, and other adverse environmental factors.

## Preparation of fire extinguisher

---

- If hot work is to be done, appropriate fire extinguishing equipment should be available.
- A dry powder or CO<sub>2</sub> fire extinguisher shall be equipped near the charging area.

## Ignition sources free

---

- Make sure to store the units in a place without continuously operating ignition sources (for example, open flames, an operating gas appliance or an operating electric heater).
- The service technicians shall not use any ignition sources with the risk of fire or explosion.
- Potential ignition sources shall be kept away from the work area where the flammable refrigerant can be released into the surroundings.
- The work area should be checked to ensure that there are no flammable hazards or ignition risks. The "No Smoking" sign shall be attached.
- Under no circumstances shall potential sources of ignition be used while detecting refrigerant leaks.
- Make sure that the seals or sealing materials have not degraded.

- Safe parts are the ones with which the worker can work in a flammable atmosphere. Other parts may result in ignition due to leakage.
- Replace components only with parts specified by Samsung. Other parts may result in the ignition of refrigerant in the atmosphere from a leak.
- Ducts connected to the product shall not contain a potential ignition source.

## Area ventilation

---

- Make sure that the work area is well ventilated before performing hot work.
- Ventilation shall be made even during the work.
- The ventilation should safely disperse any released gases and preferably expel them into the atmosphere.
- Keep any required ventilation openings clear of obstruction.

## Leakage detection methods

---

- Electronic leak detectors shall be used to detect flammable refrigerants, but the sensitivity may not be adequate or may need re-calibration. (Detection equipment shall be calibrated in a refrigerant-free area.)
- Make sure that the detector is not a potential source of ignition.
- Leak detection equipment shall be set at a percentage of the LFL (Lower flammable limit) of the refrigerant and shall be calibrated to the refrigerant employed and the appropriate percentage of gas (25 % maximum) is confirmed.
- The use of detergents containing chlorine shall be avoided for cleaning because the chlorine may react with the refrigerant and corrode the piping.
- If leakage is suspected, naked flames shall be removed.
- If a leakage is found while brazing, the entire refrigerant charge shall be recovered from the product or isolated (e.g. using shut-off valves). It shall not be directly released into the environment. Oxygen free nitrogen (OFN) shall be used for purging the system before and during the brazing process.
- The work area shall be checked with an appropriate refrigerant detector before and during work.
- Ensure that the leakage detector is appropriate for use with flammable refrigerants.

## Labeling

---

- The parts shall be labeled to ensure that they have been decommissioned and emptied of refrigerant.
- The labels shall note the date of application.





# Safety Information

- Make sure that the labels are affixed to the system to notify it contains flammable refrigerant.

## Refrigerant-related works

- Before performing refrigerant-related work, make sure the following:
  - Capacitors are discharged. Discharging capacitors must be done safely to avoid the possibility of sparking.
  - No live electrical components and wiring are exposed while charging, recovering, or purging refrigerant from the system.
  - There is continuity of earth bonding.

## Recovery

- When removing refrigerant from the system for servicing or decommissioning, it is recommended to remove the entire refrigerant charge.
- When transferring refrigerant into cylinders, make sure that only refrigerant recovery cylinders are used.
- All cylinders used for the recovered refrigerant shall be labeled.
- Cylinders shall be equipped with pressure relief valves and shut-off valves in a proper order.
- Empty recovery cylinders shall be evacuated and cooled before recovery.
- The recovery system shall operate normally according to the specified instructions and shall be suitable for refrigerant recovery.
- In addition, the calibration scales shall operate normally.
- Hoses shall be equipped with leak-free disconnect couplings.
- Before starting the recovery, check for the status of the recovery system and sealing state. Consult with the manufacturer if suspected.
- The recovered refrigerant shall be returned to the supplier in the correct recovery cylinders with the Waste Transfer Note attached.
- Do not mix refrigerants in the recovery units or cylinders.
- If compressors or compressor oils are to be removed, make sure that they have been evacuated to an acceptable level to ensure that flammable refrigerant does not remain in the lubricant.
- The evacuation process shall be performed before sending the compressor to the suppliers.
- Only the electrical heating of the compressor body is allowed to accelerate the process.
- Oil shall be drained safely from the system.
- Never install motor-driven equipment to prevent ignition.
- When removing refrigerant follow local and national regulations and follow best practices including:
  - evacuate;
  - purge the circuit with inert gas (optional for A2L);

- evacuate (optional for A2L);
- continuously flush or purge with inert gas when using a flame to open the circuit; and
- open the circuit.
- Use proper recovery cylinders appropriate for the type of refrigerant.
- Follow prescribed industry best practices for purging and evacuation.
- Oxygen free nitrogen shall be used for purging the system.

## Charging procedure

- Follow industry standard refrigerant charging best practices.
- Before recharging the system shall be pressure tested with oxygen free nitrogen gas.
- Ensure that contamination of different refrigerants does not occur when charging.
- Cylinders shall be kept in the appropriate position as per instructions.
- The refrigerant system should be grounded before charging the system.
- Label the system when charging is completed.
- Take extreme care not to overflow the refrigeration system.
- The system shall be leak tested on completion of charging before commissioning.

## About Refrigerant Detection System (RDS)

- This system includes a refrigerant detection system (RDS) and automatic leak mitigation controls.
- When a leak is detected, the RDS will stop the compressor and energize the indoor unit(s) fan for air circulation to disperse the leaked gas and display an error code.
- The RDS sensor does automatic self-test each hour and does not require any periodic maintenance.
- The sensor should be replaced upon end of life when E700 is displayed.
- For complete replacement instructions, please refer to the Service Manual.
- The RDS sensor must only be replaced with sensors as specified by Samsung.
- LEAK DETECTION SYSTEM installed. Unit must be powered except for service.

## Power supply line, fuse, or circuit breaker

- Be sure not to perform power cable modification, extension wiring, and multiple wire connection.
  - It may cause electric shock or fire due to poor connection, poor insulation, or current limit override.
- All power wiring and communication cables must comply with applicable local and national codes.



# Preparation

## Step 1-1 Typical installation overview

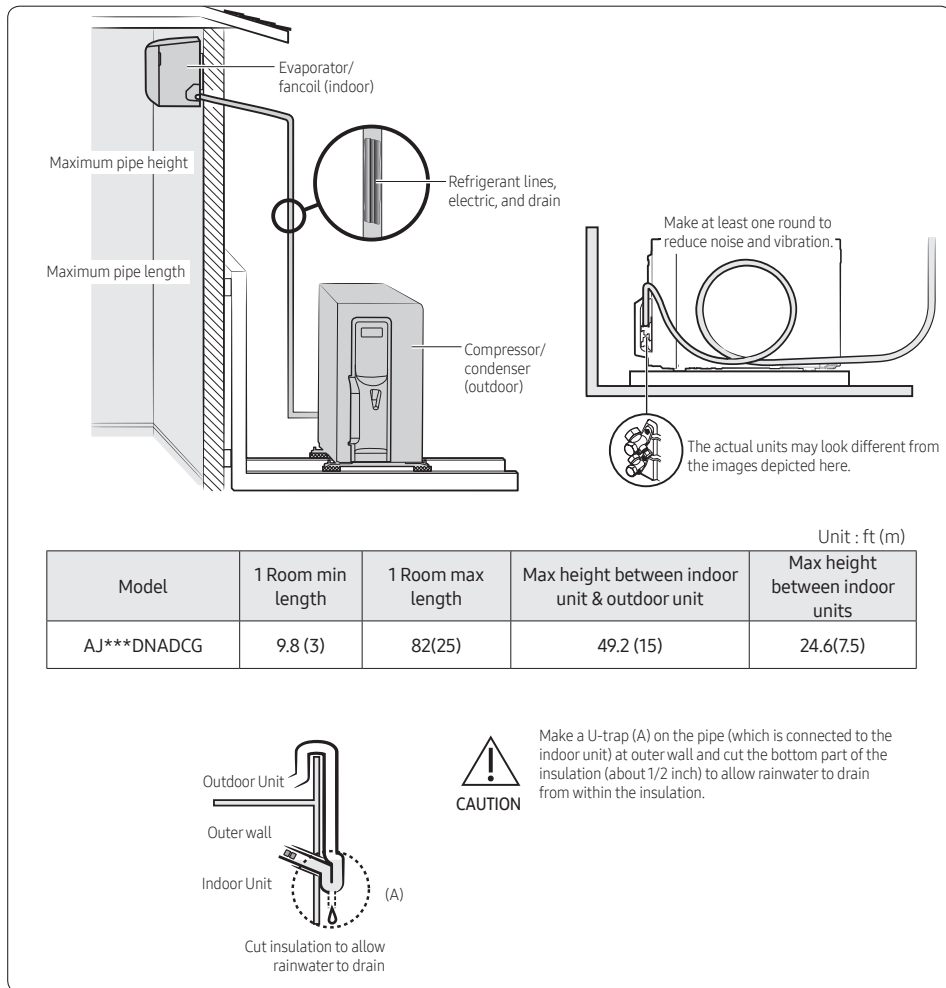

### **CAUTION**

- For the product that uses the R-32 refrigerant, Install the indoor unit on the wall 5.9 feet or higher from the floor.

# Preparation

## Step 1-2 Choosing the installation location

For more information of a Free Joint Multi (FJM) multi-zone system, install as described in the installation manual supplied with the FJM outdoor unit.

### WARNING

- Verify that a dedicated circuit breaker and a disconnect switch of the appropriate sizes for the air conditioner are preinstalled and available for use.
- Verify that the voltage and frequency of the power supply comply with the rated voltage as defined on the unit name plate.
- Verify that a suitable grounding connection is available.
- Do not install this appliance in an environment containing hazardous substances or close to equipment that releases open flames.
- Do not install this appliance near a heater or flammable material.

### CAUTION

- The manufacturer shall not be responsible for damage occurring as a result of the wrong voltage being applied to this air conditioner.
- The indoor and outdoor units must be installed in compliance with minimum clearances to ensure that both units are accessible from both sides and can be maintained or repaired. Insufficient clearance may reduce product performance, generate excessive noise, and reduce the life of some unit components.

### IMPORTANT

- Any changes or modifications to the installation described in this manual that are not expressly approved by the manufacturer could void the manufacturer's warranty.

To determine where to locate the indoor and outdoor units, you must survey the entire site and consider many variables. The goal is to select locations that comply with all safety precautions while also minimizing the total effort involved.

## Indoor unit location requirements

### WARNING

- Do not install the unit in a humid, oily, or dusty location or in a location exposed to direct sunlight, water, or rain.
- Make sure that the wall can support the unit weight.

Examine the area that the customer wants to be air conditioned. Consider the following:

- What wall location will meet minimum clearances and provide optimal product performance?
- Will the wall provide adequate support for the unit weight (wall with stud construction or concrete)? If applicable, where are the studs?
- Where will you place the wall penetration for routing the piping bundle (consisting of power and communication cables, refrigerant pipes, and the drain hose) through the wall to the outdoor unit? Will the hole intersect any plumbing or wires in the wall?
- Is the location as close as possible to where the outdoor unit will be installed, to minimize the length of piping and cables?
- Will the condensate drain inside the room, through the wall penetration to the outdoor unit, or be connected to a condensate pump?

### NOTE

- This manual covers a typical gravity-drain installation where the drain hose is routed to the outdoor unit through a hole in the wall.



### Minimum clearances for the indoor unit

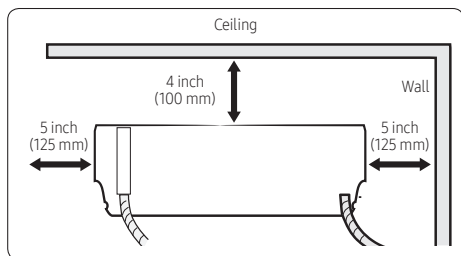

### Outdoor unit location requirements

Examine the area where the outdoor unit could be located. Consider the following:

- What location will meet minimum clearances and provide optimal product performance?
- Is there an existing level and hard foundation, such as a concrete pad, that will support the unit weight and produce minimal vibration? Installation on uneven ground may result in abnormal vibrations, noise, or problems with the unit.
- Does the unit need to be mounted on the wall?
- Where are the dedicated circuit breaker and disconnect switch located? How will you connect them to the unit?
- How will you route the piping bundle from the indoor unit? Is the location as close as possible to where the indoor unit will be installed, to minimize the length of piping and cables?
- Will the unit be sheltered from the wind? In a high-wind area, you may need to build a protective fence around the unit.
- Where will the condensate drain?



### WARNING

- The drain location must allow condensate to drain properly and prevent ice from forming on the unit in winter. If a block of ice falls from the unit, it may result in death, serious injury, or property damage. Improper or inadequate draining may result in water overflowing and property damage.



### CAUTION

- Do not connect the drain hose to existing waste pipes as odors may arise.

### Installation on an exterior wall

If the outdoor unit must be installed on an exterior wall, you will need an L-bracket to support the unit. This bracket is not included with the unit.



### WARNING

- The wall must be capable of supporting the weight of both the L-bracket and the outdoor unit. If the unit falls, it may result in crushing, electric shock, fire, or explosion that could cause death, severe personal injury, or property damage.

### Installation Guide at the seashore

Make sure to follow below guides when installing at the seashore.

- 1 Do not install the product in a place where it is directly exposed to sea water and sea breeze.
  - Make sure to install the product behind a structure (such as building) that can block sea breeze.
  - Even when it is inevitable to install the product in seashore, make sure that product is not directly exposed to sea breeze by installing a protection wall.
- 2 Consider that the salinity particles clinging to the external panels should be sufficiently washed out.
- 3 Because the residual water at the bottom of the outdoor unit significantly promotes corrosion, make sure that the slope does not disturb drainage.
  - Keep the floor level so that rain does not accumulate.
  - Be careful not to block the drain hole due to foreign substance.
- 4 When product is installed in seashore, periodically clean it with water to remove attached salinity.
- 5 Make sure to install the product in a place that provides smooth water drainage. Especially, ensure that the base part has good drainage.
- 6 If the product is damaged during the installation or maintenance, make sure to repair it.



# Preparation

- 7 Check the condition of the product periodically.
  - Check the installation site every 3 months and perform anti-corrosion treatment such as commercial water repellent grease and wax, etc., based on the product condition.
  - When the product is to be shut down for a long period of time, such as off-peak hours, take appropriate measures like covering the product.
- 8 If the product installed within 1640.4 ft (500 m) of seashore, special anti-corrosion treatment is required.
  - ※ Please contact your local SAMSUNG representative for further details.

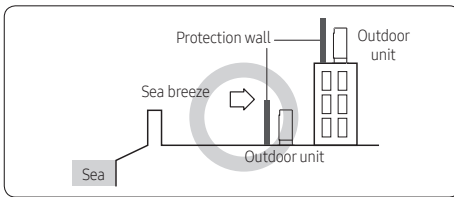
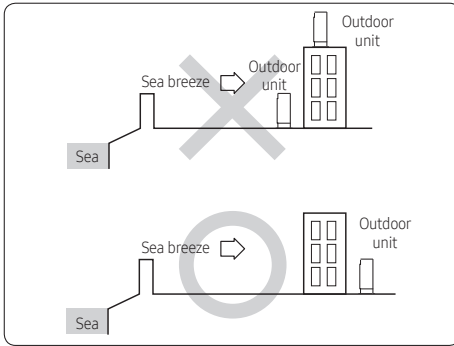

- Protection wall should be constructed with a solid material that can block the sea breeze and the height and width of the wall should be 1.5 times larger than the size of the outdoor unit. (You must secure more than 2 ft (600 mm) of space between the protection wall and the outdoor unit for air circulation.)

## Minimum clearances for the outdoor unit

If there is an obstacle in front of the air outlet, keep the outdoor unit at a distance of at least 27.5 in. (700 mm) from the obstacle.

Legends:

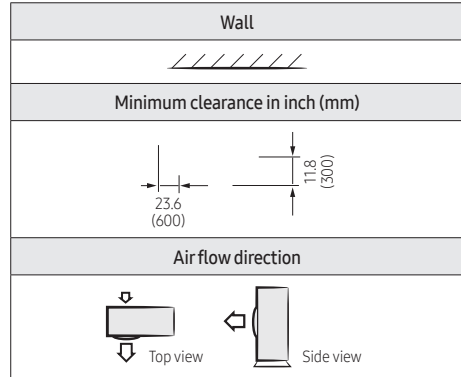

## Examples for installing one outdoor unit:

Unit: inch (mm)

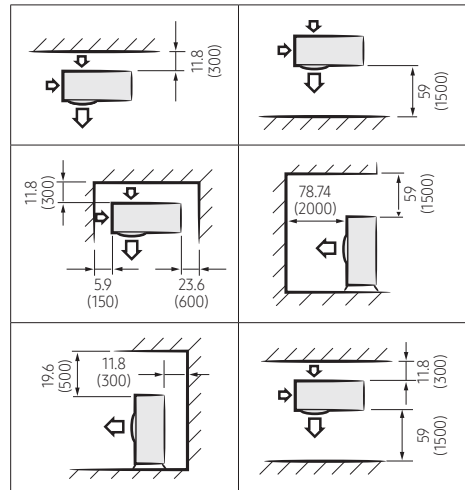

## Examples for installing multiple outdoor units:

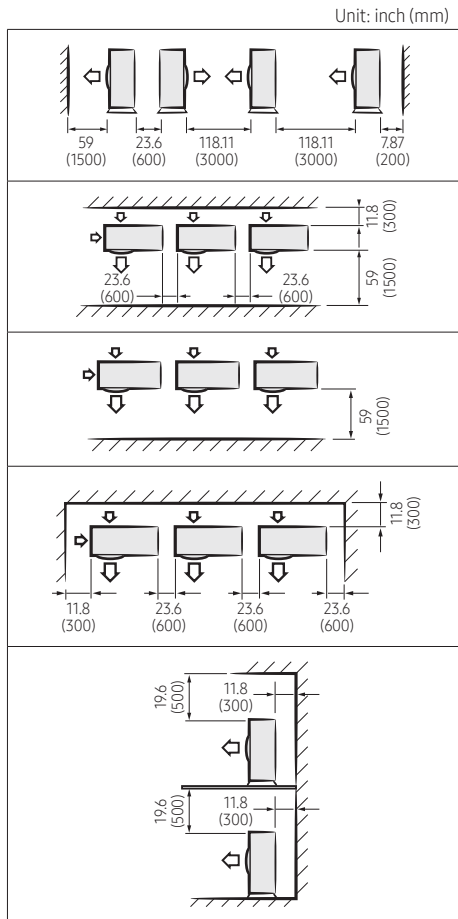

## Step 1-3 Unpacking

Upon receipt, inspect the product to verify that it has not been damaged during transport. If the product appears damaged, do not install it and immediately report the damage to your local Samsung distributor.

Packing material must be disposed of in accordance with local regulations.

### Unpacking the indoor unit

At the selected indoor unit location:

- 1 Open the indoor unit package.
- 2 Remove the left and right cushions.
- 3 Carefully remove the unit from the package.
- 4 Place the unit on a flat surface where it will be protected from possible damage.

### Unpacking the outdoor unit

At the selected outdoor unit location:





- 1 Remove the package.
- 2 Remove the top cushion.
- 3 Carefully remove the unit from the bottom cushion.
- 4 Place the unit on a flat surface where it will be protected from possible damage.

# Preparation

## Step 1-4 Preparing materials and tools

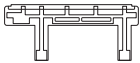
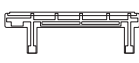
### Materials in the indoor unit package

Make sure that the indoor unit package contains the following materials:

Mounting bracket (1) **007/009/012/015***** 	Mounting bracket (1) **018/024***** 
Remote control (1) 	User manual (1) 
Installation manual (1) 	

For more information of a Free Joint Multi (FJM) multi-zone system, install as described in the installation manual supplied with the FJM outdoor unit.

### Optional accessories

For information on the accessories that are available for each model, refer to the submittal documents available at [www.samsunghvac.com](http://www.samsunghvac.com).

### Materials supplied by the installer

Make sure you have all other materials required for the selected installation method and location.

#### IMPORTANT

- No mounting hardware, tubing, cables, and other materials listed below are included with the appliance.

The required materials will vary, but may include the following:

- 6-ft electrical whip for connecting the power from the installed disconnect switch to the outdoor unit
- UV-resistant vinyl line set tape for the exposed line set
- Lines-set cover and fittings, if used
- Miscellaneous pipe hangers
- Miscellaneous screws and anchors for hanging pipe hangers, the line-set cover, the indoor unit mounting plate, and so on.
- Electrical ring connectors for connecting all power and communication wiring
- Electrical tape
- Closed cell foam tape insulation (roll)
- Outdoor unit risers or L-brackets for wall installation
- Silicone caulking for sealing the wall penetration
- Rags

### Piping and cables

Connecting the indoor and outdoor units requires a premanufactured refrigeration line set (recommended) or a line set assembled by the installer that includes.

- Soft-copper line set insulated with closed-cell foam insulation
- 16/2 cable, for communication (F1/ F2) wiring
- 14/3 flexible metallic underground cable with green grounding wire, for power wiring from the outdoor unit to the indoor unit
- 5/8-inch ID drain hose with adapter fitting, for gravity drain applications that require an extension
- Make sure that the line set is longer than needed to reach from the indoor to the outdoor unit, to allow for bends and final connections. For more on pipe lengths, see Step 1-1 Typical installation overview on page 9.



- If not using a premanufactured line set:
  - Only use insulated seamless refrigeration-grade copper pipe (Cu DHP-type according to ISO1337), degreased and deoxidized, suitable for operating pressures of at least 609 psig (4200 kPa) and for a burst pressure of at least 3002 psig (20700 kPa).
  - Do not use sanitary-type copper pipe under any circumstances.
  - Use standard cables.

Cable	Terminal	Wire Specification
Power cable	L1, L2, ground	14/3 AWG
Communication cable	F1, F2	16/2 AWG Stranded cable

#### NOTE

- This manual does not include instructions for extending cables. If you need to extend the cables, follow local codes.

## Tools

Make sure you have the required tools available.

### Safety tools

- Service disconnect lock and tag
- Circuit breaker lock and tag
- Safety glasses
- Cut-proof gloves
- Hearing protection
- Hard hat, for use in appropriate areas
- Safety vest, for visibility as required

### General tools

- 36-inch spirit level
- 8-inch to 9-inch torpedo level
- Cordless drill

- #2 Phillips-bit driver for cordless drill
- Phillips screw driver
- Slotted screw driver
- Corded hammer drill, for masonry anchors if used
- Masonry drill bit, for masonry anchors if used
- Compact bandsaw, for cutting all thread and/or unistrut channel as required
- Stud finder, for stud-wall construction as required
- 2-5-inch hole saw, standard, or diamond core for concrete or cinder block construction
- Metric hex-key set
- Razor knife
- 25-ft tape measure

### Electrical tools

- Clamp-on multimeter, for measuring volt AC, resistance, and amperage
- Non-contact thermometer (may be incorporated into multimeter)
- Wire strippers
- Wire connector crimping tool
- Cutting pliers

### Piping tools

- Flaring tool
- Deburring tool
- Piping bender, spring type
- Tubing cutter, imp style
- Tubing cutter, standard style
- Open-end torque wrench (ft.-lbs.)
- Crescent wrench

### Refrigeration tools

- Manifold set for R-32
- 5/16-inch to 1/4-inch flare adapter
- Shrader core removal tool
- 2-stage vacuum pump with oil
- Recovery machine with tank, if required
- Micron vacuum gauge
- 1/4-inch vacuum gauge hose tee
- Nitrogen regulator
- Nitrogen cylinder, charged



# Indoor Unit Installation

## Step 2-1 Attaching the mounting bracket to the wall

- 1 Hold the mounting bracket against the wall at the selected installation position (Step 1-2 on page 10), making sure that the screw holes align with the center of the studs in the wall. If the screw locations do not align with the studs, use wall anchors.

### CAUTION

- The recommended best practice is to attach the mounting bracket directly to the studs in the wall. If you did not find a suitable location with studs (in Step 1-2 on page 10), or if the wall is concrete, you must use wall anchors of a suitable type and weight capacity, and install them according to the manufacturer's instructions. Failure to do so may cause the material surrounding the joints to crumble over time and the screws to be loosened and stripped. This may result in the unit falling from the wall, which could cause physical injury or equipment damage.
- 2 Using a level, make sure that the mounting bracket is level, then mark the location of the screw holes on the wall.
  - 3 If using wall anchors, install them at the screw hole positions, following the manufacturer's instructions.
  - 4 Using six field-supplied mounting screws and anchors (if applicable), attach the bracket to the wall.

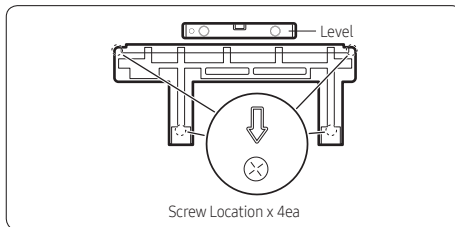

## Step 2-2 Drilling the wall penetration

- 1 Determine the position of the hole through which the piping bundle (consisting of power and communication cables, refrigerant pipes, and the drain hose) will pass. Consider the following:
  - The hole inner diameter must be 2.5 inches (65 mm).
  - The recommended hole location is behind the unit so that the hole and the piping bundle will not be visible in the room. The minimum distances between the hole and the mounting bracket are:

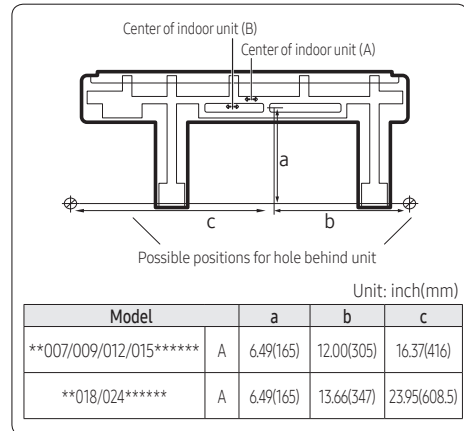

- If the hole cannot be positioned behind the unit, find a position as close to the unit as possible. The piping bundle that exits the unit and extends to the hole will need to be attached to the wall and will be visible inside the room.
- In relation to the bracket shown above, the unit is shipped with the drain hose connection on the right, the drain hose exits the unit on the left, and the refrigerant pipes are bent to exit on the left. Thus, positioning the hole to the right or below the unit, you will need to move the drain hose connection to the left and bend the pipes so that the hose and pipes exit to the right or bottom. See the figure in step 3 on page 17.

- Use a standard 2.5-inch (65-mm) hole saw to drill one hole at the selected location, at a 15° downward angle so that the drain hose will drain properly.

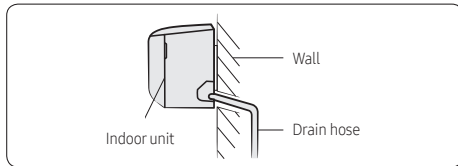

- Based on the hole location, determine where the piping bundle (drain hose, refrigerant pipes, and cables) will exit the unit.

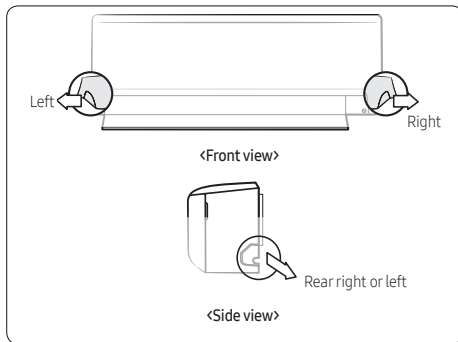

#### NOTE

- The left or right exit will only be used if the hole is not positioned behind the unit.

## Step 2-3 Connecting the refrigerant pipes

Connect indoor and outdoor units with field-supplied copper pipes by means of flare connections. Use insulated seamless refrigeration grade pipe only, (Cu DHP type according to ISO1337), degreased and deoxidized, suitable for operating pressures of at least 609psi and for burst pressure of at least 3000psi. Under no circumstances must sanitary type copper pipe be used.

#### IMPORTANT

- When installing the unit, always connect the refrigerant pipes first, followed by the electrical cables. For disassembly, always disassemble the electric cables before the refrigerant pipes.

Two short refrigerant pipes are already attached to the air conditioner:

- The smaller-diameter pipe is for the high-pressure, two-phase refrigerant.
- The larger-diameter pipe is for the low-pressure refrigerant vapor.

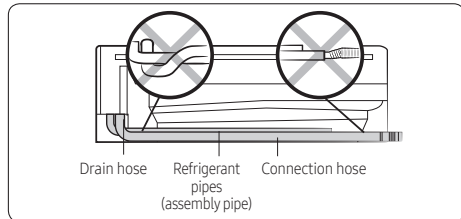

In Step 2-3, step 3 you determined the exit position for the piping bundle. The unit has three knockouts available for the left, right, and bottom exits. When the bundle exits directly from the rear, none of the knockouts are used.

- If the pipes will exit directly from the rear, skip to step 3. Otherwise, cut out the appropriate knockout piece (left, right, or bottom).
- Use a razor knife to clean the cut edges (flashing).
- The left exit is the only position that does not require bending the pipes. For other positions, bend the pipes so that they will exit in the selected exit position.
  - The bending radius should be greater than 4 inch (100 mm).
  - Bend the smaller pipe gradually to prevent kinking. The larger pipe has a preinstalled spring bender to prevent kinking.
  - Make sure that the pipes do not protrude from the back of the unit in a way that will make it difficult to attach the unit to the mounting bracket.
  - For right and bottom exits, pull the pipes out through the selected knockout opening. For left exits, the piping connections will be made in the service space behind the indoor unit (under the cover panel).

# Indoor Unit Installation

## NOTE

- If you are using the right rear exit, the pipes should be long enough to extend through the wall without needing to connect the line set first. It may be easier to connect the line set outside of the building, after you have bundled the pipes and cables and passed the bundle through the wall. In this case, do not connect the line set now. Instead, complete Step 2-4 through Step 2-6, then go outside and connect the line set as described below.
- Slowly remove the protective caps on the refrigerant pipe connections to relieve the nitrogen holding charge.
  - Connect the line set to each pipe.

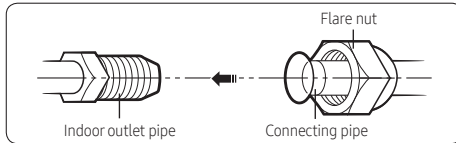

- Hand-tighten the flare nuts to make sure that they do not become stripped.

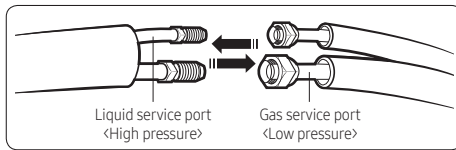

- Torque the flare connections to the following values:

Outer diameter	Torque ft·lb (N·m)
1/4 inch (6.35 mm)	10.1–13.0 (14–18)
3/8 inch (9.52 mm)	25.3–31.1 (34–42)
1/2 inch (12.70 mm)	36.2–44.8 (49–61)
5/8 inch (15.88 mm)	49.9–60.0 (68–82)

## CAUTION

- Tighten the flare nuts only to the specified torque. If a flare nut is overtightened, the flare face may crack, causing refrigerant leakage.
- Do not box in or cover the pipe connections. Make sure that the connections are accessible for testing later in the installation process and for future servicing.
  - Tape over the end of the pipes so that debris will not enter the piping when it is passed through the wall. The pipes will be insulated later in the installation process.

## Step 2-4 Connecting the power and communication cables

For more information a Free Joint Multi (FJM) multi-zone system, install as described in the installation manual supplied with the FJM outdoor unit.

## WARNING

- Do not modify the power cable in any way. Doing so may cause electric shock or fire due to poor connection, poor insulation, or current limit override. Make sure to comply with the technical standards of electrical installations and the wiring regulations in the local area.
  - This appliance must be properly grounded. Do not ground the appliance to a gas pipe, plastic water pipe, or telephone line. Failure to comply may result in electric shock, fire, and explosion.
  - If the supply cord is damaged, it must be replaced by the manufacturer, its service agent or similarly qualified persons in order to avoid a hazard.
  - Make sure that cabling is not subject to wear, corrosion, excessive pressure, vibration, sharp edges, or adverse environmental effects. Take into account the effects of aging or continual vibration from sources such as compressors or fans.
- Connect each wire to its corresponding terminal number.

Cable	Terminals
Power cable	L1, L2, ground
Communication cable	F1, F2

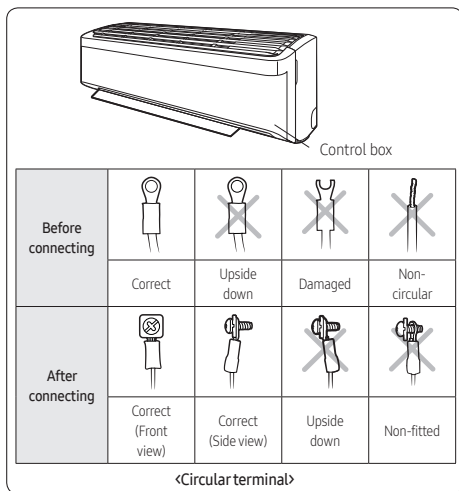

### ⚠ CAUTION

- Connect the wires firmly so that wires cannot be pulled out. Loose wires can cause the connection to overheat. Each circular terminal must match the size of its corresponding screw in the terminal block.

### ⚠ CAUTION

- For the terminal block wiring, use a wire with a ring terminal socket only. Regular wires without a ring terminal socket may become a hazard as the connections may loosen during operation.
- For the product that uses the R-32 refrigerant, be cautious not to generate a spark by keeping the following requirements:
  - Do not remove the fuses with power on.
  - Do not disconnect the power plug from the wall outlet with power on.
  - It is recommended to locate the outlet in a high position. Place the cords so that they are not tangled.

- Tighten the terminal block screw.

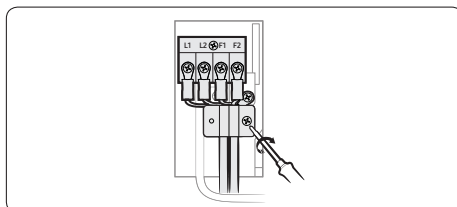

- In Step 2-3, step 3 you determined the exit position for the piping bundle. If using the left, right, or bottom exits, pass the cables through the selected knockout.

### NOTE

- Power supply cords of parts of appliances for outdoor use shall not be lighter than polychloroprene sheathed flexible cord.
- Power & Communication cable shall not exceed 98.42ft(30 m).

## Step 2-5 Connecting the drain hose

- In Step 2-3, step 3 you determined the exit position for the piping bundle. If using the right, bottom, or right rear exit, change the drain hose connection from the right to the left so that the drain hose will lie along the inside of the unit and exit to the right.

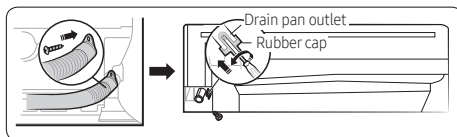

# Indoor Unit Installation

## ⚠ CAUTION

- Be careful not to puncture the plug with the screwdriver when installing it.
- 2 If using the left, right, or bottom exit, pass the drain hose through the selected knockout.

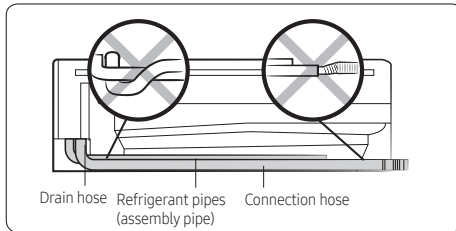

- 3 Connect a 5/8-inch ID extension drain hose to the main drain hose.

## ⚠ CAUTION

- If the diameter of the connection hose is smaller than the product's drain hose, leakage may occur.

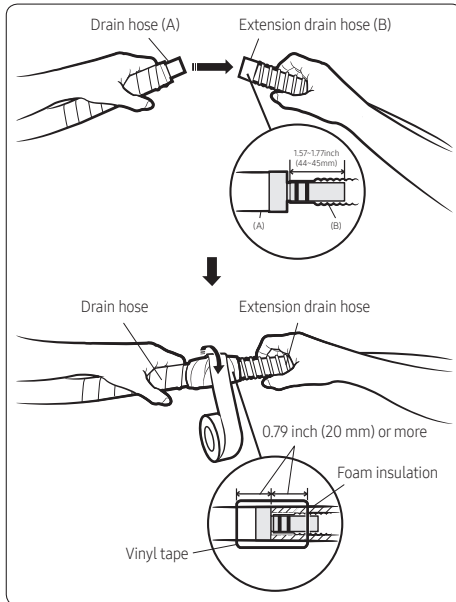

- 4 Do not box in or cover the drain hose connection. It must be accessible for testing later in the installation process and for future servicing.
- 5 If the drain hose is routed inside the room, insulate the hose so that dripping condensation does not damage the furniture or floors.

## Step 2-6 Taping the pipes, cables, and drain hose

- 1 Wrap foam insulation around the refrigerant pipes, up to the connection points. The connections must remain accessible for testing later in the installation process. Either leave slits in the insulation or do not cover the connections.

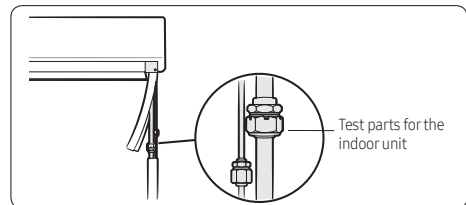
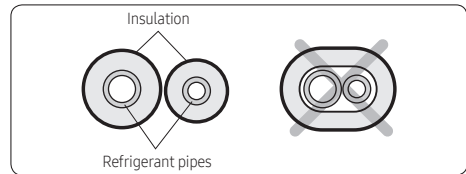

- 2 Make a piping bundle by using vinyl tape to wrap together the refrigerant pipes, power cable, communication cable, and drain hose, up to the connection points. Connection points must remain accessible for testing later in the installation process.

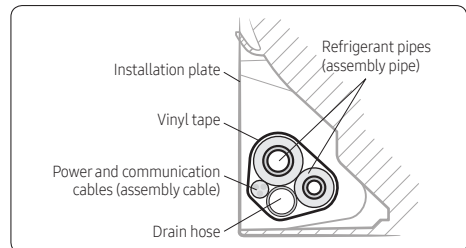

# Installation Inspection and Testing

## Step 3-1 Performing a drain leak test

- 1 Pour water into the drain pan.

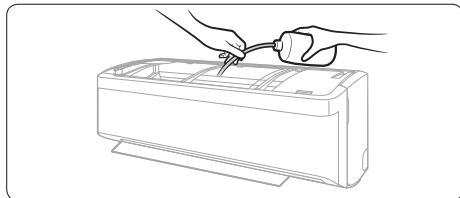

### CAUTION

- Make sure that the water does not overflow onto the electrical connection.
- 2 Check for leaks at the drain connection under the cover panel.

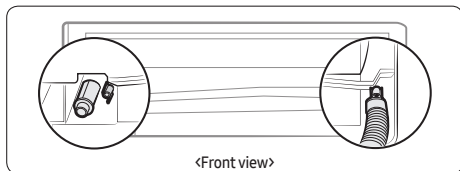

- 3 Make sure that the hose is draining properly at the outdoor unit.

## Step 3-2 Performing pressure tests using nitrogen

- 1 Install the red high-side hose of an R-32-gauge manifold set to the larger liquid/vapor line's service port.
- 2 Attach a pressure regulator to a tank of dry nitrogen.
- 3 Connect the common hose of the gauge manifold set to the pressure regulator's hose connection.
- 4 Open the service port to connect the line set to the gauge manifold set.
- 5 Pressurize the line set and indoor unit with dry nitrogen to 200 psig (adjust at the pressure regulator).
- 6 Using a soap-bubble solution suitable for refrigeration systems, check the four flare connections for leaks.

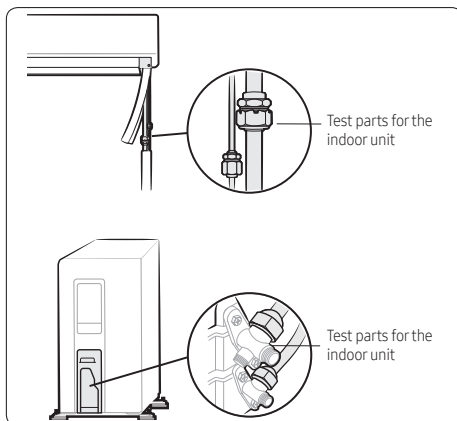

- 7 Wait 10 minutes to make sure that the pressure does not drop.
- 8 Increase the pressure to 400 psig and repeat steps 6 and 7.
- 9 Increase the pressure to 600 psig and repeat steps 6 and 7.
- 10 A drop in pressure during steps 7 through 9 indicates a system leak in the refrigeration line set or indoor unit. Perform a thorough leak check, repair the leak(s), and then repeat this procedure.
- 11 Close the gauge manifold, shut off the nitrogen tank, and remove the common hose to the pressure regulator.
- 12 Vent the nitrogen in lines to the atmosphere to prepare for system evacuation.

# Installation Inspection and Testing

## ⚠ CAUTION

- Leak-detection fluids are also suitable for use with most refrigerants. The use of detergents containing chlorine shall be avoided as the chlorine may react with the refrigerant and corrode the copper pipework.
- If a leak is suspected, all naked flames shall be removed/ extinguished.
- If leakage of refrigerant is found which requires brazing, all the refrigerants shall be recovered from the system, or isolated (using shut-off valves) in a part of the system remote from the leak.

## Step 3-3 Evacuating the system

The outdoor unit is loaded with sufficient R-32 refrigerant. Do not vent R-32 into atmosphere: it is a fluorinated greenhouse gas, covered by Kyoto Protocol, with a Global Warming Potential (GWP) = 675. You should evacuate the air in the indoor unit and in the pipe. If air remains in the refrigerant pipes, it affects the compressor. It may cause reduction of cooling capacity and malfunction. Use a vacuum pump.

## ⚠ CAUTION

- Because the system does not have filter driers, you must perform this triple evacuation procedure to remove all noncondensables and moisture from the system before charging. Failure to do so will result in reduced performance and shorter equipment life.

The time required to perform each evacuation will depend on the capacity (CFM) of the vacuum pump used.

- 1 Install a micron vacuum gauge to the larger liquid/vapor line's service port on the branch of a tee.
- 2 Install the red high-side hose of an R-32 gauge manifold set to the smaller liquid/vapor line's service port on the run of the tee.
- 3 Attach a vacuum pump to the common hose of the manifold set.
- 4 To ensure optimal performance, verify that the vacuum pump's oil has been changed recently.
- 5 With the service port closed and the manifold gauge open, start the vacuum pump and make sure that the vacuum level drops below 4000 microns (as read on the micron gauge). If it is difficult to achieve a proper vacuum, a leak in the hoses is likely. Repair the leak(s) and/ or check performance of vacuum pump, then repeat this step.
- 6 Open the service port to connect the system to the manifold.
- 7 Evacuate until 4000 microns is achieved, for at least 10 minutes.

- 8 Close the gauge manifold valve, shut off the vacuum pump, and remove the common hose.
- 9 Connect the hose to the nitrogen pressure regulator and bleed the hose by opening the end of the common hose closest to the manifold.
- 10 Open the high-pressure manifold valve and slowly bring the system pressure to atmosphere (50 kPa).
- 11 Close the manifold and nitrogen cylinder and remove the common hose.
- 12 Reconnect the common hose to the vacuum pump. Repeat steps 6 through 12, alternating between breaking the vacuum with dry nitrogen and evacuating, until system evacuation has occurred three times, to the following vacuum levels:

Evacuation	Microns
First	4000
Second	2000
Third	500

- 13 After evacuating to at least 500 microns for the third time, close the gauge manifold valve and wait 10 minutes, making sure that the vacuum level in the system does not decrease. If it does, a small leak is likely. Repair the leak and repeat the evacuation process.

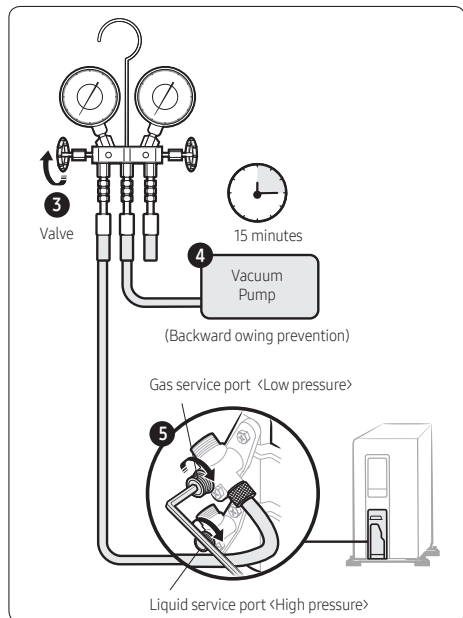

Error indicator	Error	Measures for the installer to take
88 Display		
C 101	Communication error between indoor and outdoor units	<ul style="list-style-type: none"> <li>Check the cables between the indoor and outdoor units. See if the power cable or communication cable is crossed.</li> </ul>
C 121	Error on indoor temperature sensor	<ul style="list-style-type: none"> <li>Make sure that the indoor temperature sensor is properly connected.</li> </ul>
C 122 C 123	Error on indoor heat exchanger	<ul style="list-style-type: none"> <li>Make sure that the evaporator temperature sensor is properly connected.</li> </ul>
C 154	Error on indoor fan motor	<ul style="list-style-type: none"> <li>Make sure that the evaporator motor is properly connected to the board.</li> <li>Check for a foreign substance inside the unit that may be preventing the blower wheel from turning.</li> </ul>
88 C 162 C 163	EEPROM/Option error	<ul style="list-style-type: none"> <li>Reset the option codes.</li> </ul>
C 422	Refrigerant flow blocking error	<ul style="list-style-type: none"> <li>Make sure that the service valves are completely open.</li> <li>Check for any blockage in the refrigerant pipe that connects the indoor and outdoor units.</li> <li>Check for refrigerant leaks.</li> <li>Check the cables between the indoor and outdoor units. See if the power cable or communication cable is crossed.</li> </ul>
C 554	Lack of refrigerant (for inverter models only)	<ul style="list-style-type: none"> <li>Check for refrigerant leaks between the valve and pipe connection.</li> </ul>
C 116	Indoor unit R-32 sensor short/open	<ol style="list-style-type: none"> <li>1 Check R-32 sensor connector.</li> <li>2 Check R-32 sensor wire.</li> <li>3 Check R-32 sensor.</li> <li>4 Change R-32 sensor.</li> </ol>
C 698	Refrigerant leak sensor failure error	<ol style="list-style-type: none"> <li>1 Check R-32 sensor connector.</li> <li>2 Check R-32 sensor.</li> <li>3 Change R-32 sensor.</li> </ol>
C 699	R-32 detection sensor replacement alarm	<ul style="list-style-type: none"> <li>Change R-32 sensor.</li> </ul>
C 700	R-32 detection sensor unavailable alarm	<ul style="list-style-type: none"> <li>Change R-32 sensor.</li> </ul>





# Installation Inspection and Testing

## Step 3-4 Performing final checks and trial operation

### WARNING

Stop the unit, disconnect the power, and contact Samsung technical support if any of the following occurs:

- The unit produces a burning smell or smoke.
- The power cable is hot or damaged.
- The unit is very noisy.
- Any foreign substance, such as water, has entered the appliance.
- The appliance becomes flooded.

- 1 Check the following:
  - Strength of the installation site
  - Tightness of pipe connection to detect gas leak
  - Electric wiring connection
  - Heat-resistant insulation of the pipe
  - Drainage
  - Grounding conductor connection
  - Correct operation (Take the following steps.)
- 2 Press the  (Power) button on the remote control to check the following:
  - The indicator on the indoor unit lights up.
  - The airflow blade opens and the fan energizes for operation.
- 3 Press the  (Mode) button to select Cool or Heat mode. Then take the following sub-steps:
  - In Cool mode, use the Temperature button to set the set temperature to 61 °F (16 °C)
  - In Heat mode, use the Temperature button to set the set temperature to 86 °F (30 °C)
  - Check whether, approximately 3 to 5 minutes later, the outdoor unit starts, and a cool or warm air blows out.
  - After 12 minutes of stationary condition, check the indoor unit air treatment.
- 4 Press the  (Fan) button to check whether the airflow blades work properly.
- 5 Press the  (Power) button to stop the trial operation.

# Setting the installation options

## Setting the installation options

This product has installation options depending on the user's installation environment. Even after the product ships, it is possible to input option changes to the indoor unit using the transmission packet of the remote control.

This chapter provides a method for setting the installation options.

### STEP1. Common steps for setting the options

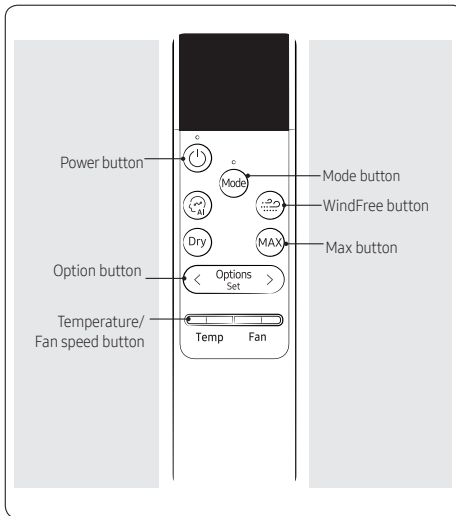

#### NOTE

- The remote control display and buttons may vary depending on the model.

- Enter the mode for setting the options:
  - Connect the remote control by using the USB port (C-Type) at the bottom of the remote control.
  - Press and hold the and button simultaneously for 5 seconds. (After connecting the remote control, press the and button within 10 seconds.)
  - Make sure the remote control display shown as
    - When setting the option code, press the next button within 5 seconds so that the setting is not interrupted.

- Set the option values

#### CAUTION











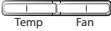

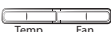

- The total number of available options are 24: SEG1 to SEG24.
- Because SEG1, SEG7, SEG13, and SEG19 are the page options used by the previous remote control models, the modes to set values for these options are skipped automatically.
- Set a 2-digit value for each option pair in the following order: SEG2 and SEG3 → SEG4 and SEG5 → SEG6 and SEG8 → SEG9 and SEG10 → SEG11 and SEG12 → SEG14 and SEG15 → SEG16 and SEG17 → SEG18 and SEG20 → SEG21 and SEG22 → SEG23 and SEG24

SEG1	SEG2	SEG3	SEG4	SEG5	SEG6
0	X	X	X	X	X
SEG7	SEG8	SEG9	SEG10	SEG11	SEG12
1	X	X	X	X	X
SEG13	SEG14	SEG15	SEG16	SEG17	SEG18
2	X	X	X	X	X
SEG19	SEG20	SEG21	SEG22	SEG23	SEG24
3	X	X	X	X	X

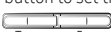



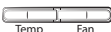

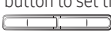

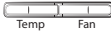

# Setting the installation options

Example Option code : 013FC5-10B22A-271E00-371020 → 13-FC-50-B2-2A-71-E0-07-10-20

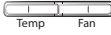
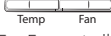
Take the steps presented in the following table:

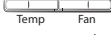
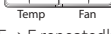

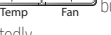

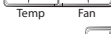
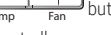



Steps	Remote control display
<p><b>1</b> Setting SEG 2</p> <p>Press the  button to set the display panel to 1.</p> <p>Every time you press the  button, the display panel reads 0 → 1 → 2 → 3 → ... → 9 → A → B → C → D → E → F repeatedly.</p>	
<p><b>2</b> Setting SEG 3</p> <p>Press the  button to set the display panel to 3.</p> <p>Every time you press the  button, the display panel reads 0 → 1 → 2 → 3 → ... → 9 → A → B → C → D → E → F repeatedly.</p>	
<p><b>3</b> Press the  button to set next options.</p>	
<p><b>4</b> Setting SEG 4</p> <p>Press the  button to set the display panel to F.</p> <p>Every time you press the  button, the display panel reads 0 → 1 → 2 → 3 → ... → 9 → A → B → C → D → E → F repeatedly.</p>	
<p><b>5</b> Setting SEG 5</p> <p>Press the  button to set the display panel to C.</p> <p>Every time you press the  button, the display panel reads 0 → 1 → 2 → 3 → ... → 9 → A → B → C → D → E → F repeatedly.</p>	
<p><b>6</b> Press the  button to set next options.</p>	
<p><b>7</b> Setting SEG 6</p> <p>Press the  button to set the display panel to 5.</p> <p>Every time you press the  button, the display panel reads 0 → 1 → 2 → 3 → ... → 9 → A → B → C → D → E → F repeatedly.</p>	
<p><b>8</b> Setting SEG 8</p> <p>Press the  button to set the display panel to 0.</p> <p>Every time you press the  button, the display panel reads 0 → 1 → 2 → 3 → ... → 9 → A → B → C → D → E → F repeatedly.</p>	

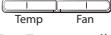



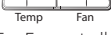
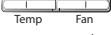
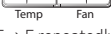

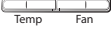

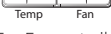



Steps	Remote control display
<p>9 Press the  button to set next options.</p>	
<p>10 Setting SEG 9 Press the  button to set the display panel to B. Every time you press the  button, the display panel reads 0 → 1 → 2 → 3 → ... 9 → A → B → C → D → E → F repeatedly.</p>	
<p>11 Setting SEG 10 Press the  button to set the display panel to 2. Every time you press the  button, the display panel reads 0 → 1 → 2 → 3 → ... 9 → A → B → C → D → E → F repeatedly.</p>	
<p>12 Press the  button to set next options.</p>	
<p>13 Setting SEG 11 Press the  button to set the display panel to 2. Every time you press the  button, the display panel reads 0 → 1 → 2 → 3 → ... 9 → A → B → C → D → E → F repeatedly.</p>	
<p>14 Setting SEG 12 Press the  button to set the display panel to A. Every time you press the  button, the display panel reads 0 → 1 → 2 → 3 → ... 9 → A → B → C → D → E → F repeatedly.</p>	
<p>15 Press the  button to set next options.</p>	
<p>16 Setting SEG 14 Press the  button to set the display panel to 7. Every time you press the  button, the display panel reads 0 → 1 → 2 → 3 → ... 9 → A → B → C → D → E → F repeatedly.</p>	



# Setting the installation options

Steps	Remote control display
<p><b>17</b> Setting SEG 15</p> <p>Press the  button to set the display panel to 1.</p> <p>Every time you press the  button, the display panel reads 0 → 1 → 2 → 3 → ... 9 → A → B → C → D → E → F repeatedly.</p>	
<p><b>18</b> Press the  button to set next options.</p>	
<p><b>19</b> Setting SEG 16</p> <p>Press the  button to set the display panel to E.</p> <p>Every time you press the  button, the display panel reads 0 → 1 → 2 → 3 → ... 9 → A → B → C → D → E → F repeatedly.</p>	
<p><b>20</b> Setting SEG 17</p> <p>Press the  button to set the display panel to 0.</p> <p>Every time you press the  button, the display panel reads 0 → 1 → 2 → 3 → ... 9 → A → B → C → D → E → F repeatedly.</p>	
<p><b>21</b> Press the  button to set next options.</p>	
<p><b>22</b> Setting SEG 18</p> <p>Press the  button to set the display panel to 0.</p> <p>Every time you press the  button, the display panel reads 0 → 1 → 2 → 3 → ... 9 → A → B → C → D → E → F repeatedly.</p>	
<p><b>23</b> Setting SEG 20</p> <p>Press the  button to set the display panel to 7.</p> <p>Every time you press the  button, the display panel reads 0 → 1 → 2 → 3 → ... 9 → A → B → C → D → E → F repeatedly.</p>	

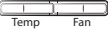

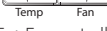

Steps	Remote control display
<p>24 Press the  button to set next options.</p>	
<p>25 Setting SEG 21            Press the  button to set the display panel to 1.            Every time you press the  button, the display panel reads 0 → 1 → 2 → 3 → ... 9 → A → B → C → D → E → F repeatedly.</p>	
<p>26 Setting SEG 22            Press the  button to set the display panel to 0.            Every time you press the  button, the display panel reads 0 → 1 → 2 → 3 → ... 9 → A → B → C → D → E → F repeatedly.</p>	
<p>27 Press the  button to set next options.</p>	
<p>28 Setting SEG 23            Press the  button to set the display panel to 2.            Every time you press the  button, the display panel reads 0 → 1 → 2 → 3 → ... 9 → A → B → C → D → E → F repeatedly.</p>	
<p>29 Setting SEG 24            Press the  button to set the display panel to 0.            Every time you press the  button, the display panel reads 0 → 1 → 2 → 3 → ... 9 → A → B → C → D → E → F repeatedly.</p>	





# Setting the installation options

- 3 Upon completion of the selection, check you made right selections.

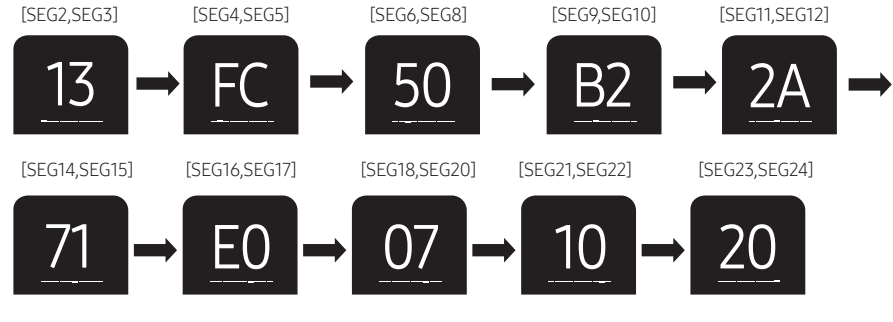
Press the  button to set the display part and check the display part.  
→ The display part shows like below when each time you press the  button.



- 4 Press the  button.
- 5 When pressing the  (Power) button with the direction of the remote control for the sound "Ding" or "Dinging" is heard, then the input of the option is completed. (If the dinging sound isn't heard, try pressing the  (Power) button again.)



## STEP 2. Setting the installation options in a batch

Installation option no. for an indoor unit : 02XXXX-1XXXXX-2XXXXX-3XXXXX

The installation option can be set at the factory differently depending on the function of each model.

Various option items of each address assigned within the installation option are shown in the following table.

- Among the values expressed in each address, "Reserved" cannot be changed because it means no options are configurable, or a unique function for the model is already assigned. The options SEG4, SEG5, SEG8, SEG14, SEG15, SEG17, SEG18, and SEG20 can be changed to reflect the present installation conditions, if needed.
  - Before changing the options, make sure that the power is supplied to the indoor unit. If the indoor unit is not plugged in, it must include a power supply so that the remote control's option transmission packet can be input to the indoor unit.
  - When changing the options according to the installation environment, there are two methods: changing 24 digits in a batch and changing the options individually.
  - To change in a batch, you must first know the entire 24-digit installation options of the model from the service manual. Set the installation options of indoor units by following the steps in STEP 1. Common steps for setting the options on page 26 after determining the specific address segment values required to change the installation options.
  - If you do not know the entire installation options, refer to the following section STEP 3. Changing the options individually on page 31.
  - Description of option segments with changeable values

① SEG4 : set for using "Indoor external temperature sensor" or "fan Thermo off control"  
 (Fan thermo off control only: 1, external sensor only: 6, using both: 7)



### CAUTION

- "Fan Thermo Off control" is only available for an indoor unit for Free Joint Multi.  
 When "Fan Thermo Off control" is matched with a Single Zone High-Wall system, the setting cannot be made using this option. But you can set this option by referring to the following section STEP 3. Changing the options individually on page 31.

② SEG5 : To use a central controller, enter 1.

③ SEG8 : To use an external drain pump, enter 8.



### NOTE

- If the SEG8 is set to 'Use', the SEG14-External Contact Control will be set to DISABLE automatically.

④ SEG14 : As an External Contact Control option, check the installation site and then select the appropriate option.



### NOTE

- If SEG14 is not set to 'default', SEG8-the external drain pump will not be available.

⑤ SEG15 : Set an output option according to external control (Thermo on - 0, Operation on - 1)

⑥ SEG17 : Control the received sound tone of the remote control of the indoor unit. (Buzzer use - 0, disuse - 1)

⑦ SEG18 : Change the filter usage time of the indoor unit (500HR - 1, 1000HR - 2)

⑧ SEG20 : Set this option to control an indoor unit using a specific remote control.



# Setting the installation options

Option	SEG1		SEG2			SEG3			SEG4			SEG5			SEG6		
Function	Page		Mode			Reserved			Use of external room temperature sensor / Fan Thermo Off control			Use of central control			Reserved		
Indication and details	Indication	Details	Indication	Details	-				Indication	Details	Factory set	Indication	Details	Factory set			
	0		2	Installation	-				0	Disuse	0	0	Disuse	1			
									1	Use/Disuse	0	1	use				
						6	Disuse/Use										
									7	Use/Use							
Option	SEG7		SEG8			SEG9			SEG10			SEG11			SEG12		
Function	Page		Use of drain pump			Reserved			Reserved			Reserved			Reserved		
Indication and details	Indication	Details	Indication	Details	Factory set												
	1		0	Disuse	0												
			8	Use external drain pump													
Option	SEG13		SEG14			SEG15			SEG16			SEG17			SEG18		
Function	Page		Use of external control			Setting the output of external control			Reserved			Buzzer control (Receiving tone of indoor unit)			Use Time of Filter		
Indication and details	Indication	Details	Indication	Details	Factory set	Indication	Details	Factory set				Indication	Details	Factory set	Indication	Details	Factory set
	2		0	Disuse	0	0	Thermo on	0				A	Use	A	0	Disuse	1
			1	On/Off control		1	Operation on					B	Disuse		1	500HR	
			2	Off control		2	Use (Operating heater → Fan on) + Disuse Emergency Heat					-	-		2	1000HR	
			3	Window On/Off control		3	Use (Operating heater → Fan off) + Disuse Emergency Heat					-	-		-	-	
			8	Reverse control	0	4	Use (Operating heater → Fan on/ Defrosting → Fan off) + Disuse Emergency Heat	0				-	-	A	-	-	
			9	On/off & Reverse control		5	Use (Operating heater → Fan on) + Use Emergency Heat					-	-		-	-	
			A	Off & Reverse control		6	Use (Operating heater → Fan off) + Use Emergency Heat					-	-		-	-	
			B	Window on/off & Reverse control		7	Use (Operating heater → Fan on/Defrosting → Fan off) + Use Emergency Heat					-	-		-	-	
	Option	SEG19		SEG20			SEG21			SEG22			SEG23			SEG24	
Function	Page		Wireless controller address			Reserved			Reserved			Reserved			Reserved		
Indication and details	Indication	Details	Indication	Details	Factory set												
	3		0 or 1	Indoor1	0												
			2	Indoor2													
			3	Indoor3													
			4	Indoor4													

Installation option no. for an indoor unit : 05XXXX-100000-200000-300000

Option	SEG1		SEG2		SEG3 (*1)			SEG4 (*2)			SEG5 (*3)			SEG6			
Function	Page		Mode		Auxiliary heater offset temp. and time delay			Maximum outdoor temperature for auxiliary heater use			External heat compressor lockout temperature			Auto mode manual fan speed control / Motion Detect Sensor (MDS) UK			
Indication and details	Indication	Details	Indication	Details	Indication	Details	Factory set	Indication	Details	Factory set	Indication	Details	Factory set	Indication	Details	Factory set	
	0		5	Installation Option 2	0	No temperature offset	No delay	0	Disuse		0	Disuse		0	Disable		
					1	No temperature offset	10 minutes		1	65°F (18.3°C)		1	45°F (7.2°C)		1	Enable/Disable	
					2	No temperature offset	20 minutes		2	60°F (15.6°C)		2	40°F (4.4°C)		2	Disable/Enable	
					3	2.7°F(1.5°C)	No delay		3	55°F (12.8°C)		3	35°F (1.7°C)		3	Enable	
					4	2.7°F(1.5°C)	10 minutes		4	50°F (10°C)		4	30°F (-1.1°C)		-	-	
					5	2.7°F(1.5°C)	20 minutes		5	45°F (7.2°C)		5	25°F (-3.9°C)		-	-	
					6	5.4°F(3°C)	No delay	0	6	40°F (4.4°C)	0	6	20°F (-6.7°C)	0	-	-	3
					7	5.4°F(3°C)	10 minutes		7	35°F (1.7°C)		7	15°F (-9.4°C)		-	-	
					8	5.4°F(3°C)	20 minutes		8	30°F (-1.1°C)		8	10°F (-12.2°C)		-	-	
					9	8.1°F(4.5°C)	No delay		9	25°F (-3.9°C)		9	5°F (-15°C)		-	-	
					A	8.1°F(4.5°C)	10 minutes		A	20°F (-6.7°C)		A	0°F (-17.8°C)		-	-	
					B	8.1°F(4.5°C)	20 minutes		B	15°F (-9.4°C)		B	-5°F (-20.6°C)		-	-	
			C		10.8°F(6°C)	No delay		C	10°F (-12.2°C)		C	-10°F (-23°C)		-	-		
			D	10.8°F(6°C)	10 minutes		D	5°F (-15°C)		D	-15°F (-26°C)		-	-			
			E	10.8°F(6°C)	20 minutes		E	0°F (-17.8°C)		E	-20°F (-29°C)		-	-			
Option	SEG7		SEG8		SEG9			SEG10			SEG11			SEG12			
Function	Page		Reserved		Reserved			Reserved			Reserved			Reserved			
Indication and details	Indication	Details															
	1																
Option	SEG13		SEG14		SEG15			SEG16			SEG17			SEG18			
Function	Page		Reserved		Reserved			Reserved			Reserved			Reserved			
Indication and details	Indication	Details															
	2																
Option	SEG19		SEG20		SEG21			SEG22			SEG23			SEG24			
Function	Page		Reserved		Reserved			Reserved			Reserved			Reserved			
Indication and details	Indication	Details															
	3																

# Setting the installation options

## WARNING

- Ensure that the external heater connected to a Samsung indoor unit is equipped with an overheating prevention system and meets the UL 60335-2-40 standard.
- The external heater must be set so that it does not operate if the indoor unit malfunctions and appropriate airflow is impossible.
- If the indoor unit has a problem and its fan is not working, and the external heater is operating without an overheating prevention system, it may result in a fire, property damage and/or personal injury.
- Installing an external heater without following the instructions provided by the manufacturer may result in electric shock, fire, property damage and/or personal injury.

(\*1) Defines the offset temperature for external heater ON/OFF controls. / Time Delay for heater operation

Example 1) Selecting option 2 will set to 0°F (0°C) offset temperature. / Time Delay for heater operation is 20 minutes.

Thermo ON: Heater operates when room temperature is  $\leq$  set temperature +  $\Delta T$  (Thermal Compensation) - 0°F (0°C) and 20 minutes have passed.

Thermo off: Heater stops when room temperature is  $>$  set temperature +  $\Delta T$  (Thermal Compensation) - 0°F (0°C) + 1.8°F (1°C).

Example 2) Selecting option 4 will set to 2.7°F (1.5°C) offset temperature. / Time Delay for heater operation is 10 minutes.

Thermo on: Heater operates when room temperature is  $\leq$  set temperature +  $\Delta T$  (Thermal Compensation) - 2.7°F (1.5°C) and 10 minutes have passed.

Thermo off: Heater stops when room temperature is  $>$  set temperature +  $\Delta T$  (Thermal Compensation) - 2.7°F (1.5°C) + 1.8°F (1°C).

(\*2) EH Lockout, restrict heating output above the set outdoor temperature.

※ Restriction is lifted below [set temperature - 3.6°F (2°C)]

Example 1) Selecting option 3 will restrict heating operation when the outdoor temperature is is 55°F (12.8°C) or above. Restriction is lifted when outdoor temperature falls below 51°F (10.8°C).

(\*3) HP Lockout, SET Thermo off process below the set outdoor temperature.

※ Restriction is lifted above [set temperature + 3.6°F (2°C)]

Example 1) Selecting option 3 will SET Thermo off when the outdoor temperature is is 35°F (1.7°C) or below. Restriction is lifted when outdoor temperature rises above 39°F (3.7°C).

Set HP Lockout temperature is adjusted to -5.08°F (-20.6°C) if the HP Lockout temperature is equal or higher than EH Lockout.

### STEP 3. Changing the options individually

When you want to change the value of a specific option, refer to the following table and follow the steps in STEP1. Common steps for setting the options on page 26.

(Enter the set address of the installation option to change in SEG4 and SEG5 in the table below, enter the change option value in SEG6. The values of SEG1, SEG2, SEG3, and SEG4 are always 0, D, 2 in the same order as in the following table.)

Option	SEG1		SEG2		SEG3		SEG4		SEG5		SEG6	
Function	Page		Mode		Option mode to change		Tens position of the option number		Units position of the option number		New value	
Indication and details	Indication	Details	Indication	Details	Indication	Details	Indication	Details	Indication	Details	Indication	Details
		0		D		2		Tens position value	0 to 9	Units position value	0 to 9	New value

Example: Changing the Buzzer control (SEG17) option of the installation options to 1 (disuse).

Option	SEG1		SEG2		SEG3		SEG4		SEG5		SEG6	
Function	Page		Mode		Option mode to change		Tens position of the option number		Units position of the option number		New value	
Indication	0		D		2		1		7		1	

#### NOTE

- How to set the thermo off option for a Single Zone High-Wall system is shown in the following option table:

Option	SEG1		SEG2		SEG3		SEG4		SEG5		SEG6	
Function	Page		Mode		Option mode to change		Tens position of the option number		Units position of the option number		New value	
Indication	0		D		1		2		4		F	

# Maintenance Procedures

## Repair

### Performing the gas leak tests

In case of repair of the refrigerant circuit, the following procedure must be kept to consider flammability.

- 1 Remove the refrigerant.
- 2 Flush the system with nitrogen blowing for safety
- 3 Repeat the previous step several times until no refrigerant is within the system
- 4 Perform the repair work
- 5 Conduct a pressure test
- 6 Purge the refrigerant circuit with inert gas
- 7 Perform vacuuming
- 8 Charge with refrigerant
- 9 Perform a leak test
- 10 Perform a second leak test within one month



### CAUTION

- Compressed air or oxygen shall not be used.
- Flush the system with nitrogen blowing, fill the refrigerant until the working pressure is reached, ventilate to the atmosphere, and then pull down to a vacuum state.
- For the final nitrogen blowing charge, the system shall be ventilated down to the atmosphere pressure.
- The procedure is vital in case of brazing on the piping.
- Make sure that the outlet of the vacuum pump is not closed to any ignition sources and there is ventilation available.
- Do not apply any permanent inductive or capacitance loads to the circuit without ensuring that this will not exceed the permissible voltage and current permitted for the air conditioner.

### Component checking

- Sealed electrical equipment shall be replaced.
- Particular attention shall be paid to the following to ensure safety while working on electrical components:
  - The casing shall not be modified because it can affect the level of protection. The corresponding modifications include damage to cables and seals, excessive number of connections, terminals that do not comply with original specifications, incorrect fitting of glands, etc.
  - Ensure that the apparatus is mounted securely.
  - Ensure that seals or sealing materials have not degraded to prevent the ingress of flammable atmospheres.
  - Replacement parts shall be following the manufacturer's specifications.
- Intrinsically safe components must be replaced.

## Decommissioning

The following requirements must be fulfilled before and while taking the decommissioning procedure:

- Only qualified, licensed professionals shall perform refrigerant recovery and decommissioning. Before decommissioning, the worker shall become familiar with the product.
  - All recovery equipment and cylinders shall conform to appropriate standards. Only approved cylinders, with pressure relief valves, for the type of refrigerant shall be used.
  - Recover refrigerant following industry standard procedure for flammable refrigerants.
  - When draining compressors oil care must be taken that there is no flammable refrigerant in the compressor and that the compressor is not hot. Oil should be handled according to local and federal regulations.
  - Recovered refrigerant shall not be mixed or reused. It shall be processed according to national, state and local regulations.
  - The entire refrigerant shall be recovered safely.
  - Before starting the process, oil and refrigerant samples shall be taken just in case analysis is required for reuse.
  - Before starting the process, a power supply must be available.
- 1 Be familiar with the equipment details.
  - 2 Isolate the system electrically.
  - 3 Before starting the process, make sure that:
    - Any mechanical equipment is available for handling refrigerant cylinders.
    - All PPE (personal protective equipment) is available for servicing.
    - The recovery process shall be supervised by a competent person.
    - The recovery equipment and cylinders comply with the standards.
  - 4 Pump down the refrigeration system, if possible.
  - 5 If vacuuming is not possible, make a manifold so that refrigerant can be easily removed from the parts of the system.
  - 6 Make sure that the cylinders are placed on the scales before recovery.
  - 7 Run the recovery system following the manufacturer's instructions.
  - 8 Do not overcharge the cylinders. (No more than 80 %)
  - 9 Be sure to keep the cylinder within the maximum working pressure, even temporarily.
  - 10 After charging, make sure that the cylinders and the equipment are promptly removed from the site and all isolation valves are closed.
  - 11 Recovered refrigerant shall not be charged into another refrigeration system unless it is cleaned and checked.
  - 12 After decommissioning, the system shall be labeled stating that it has been decommissioned. The label shall be dated and signed.
  - 13 Ensure that there are labels on the equipment indicating the equipment contains flammable refrigerant.

# Sub PCB installation (optional accessory)

(Wired remote controller, central remote controller etc.)

- 1 Turn the power off and take off the cover panel of the indoor unit.

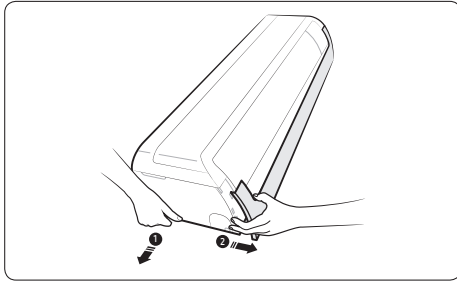

- 2 Attach the Sub PCB to the Sub PCB case.
- 3 Assemble the Sub PCB case to the indoor unit.

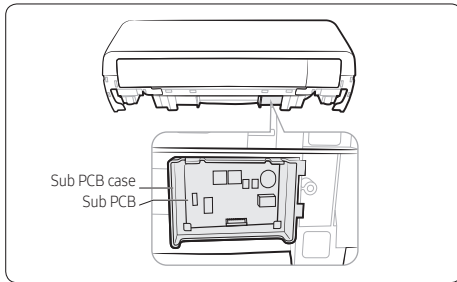

- 4 Find the PCB wire, and connect the wire to the Sub PCB as seen in the picture.

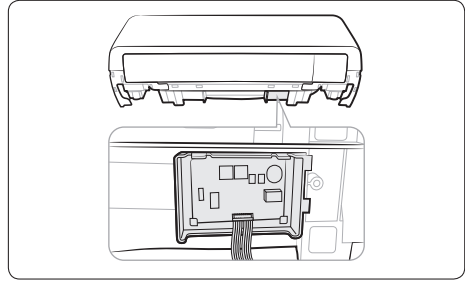

- 5 Connect the wire(remote controller, central remote controller etc) to the Sub PCB.
- 6 Assemble the PCB Cover and the front panel.  
※ If the Sub PCB is not installed, arrange the wire for multi system (connection) as shown in the illustration.

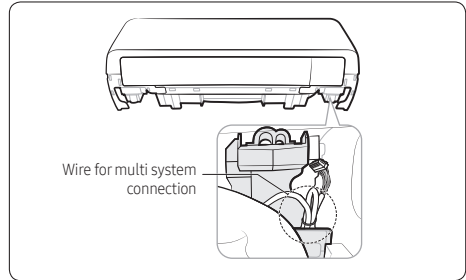

## NOTE

- The Sub PCB is connected for controlling the system using a wired remote controller, and/or a centralized remote controller.

**SAMSUNG**