

# Air conditioner

# Installation manual

---

**AC\*\*\*DNADCG**

---

- Thank you for purchasing this Samsung air conditioner.
- Before operating this unit, please read this manual carefully and retain it for future reference.

**SAMSUNG**

# Contents

---

<b>Safety Information</b>	<b>3</b>
Safety Information	3
<b>Installation</b>	<b>8</b>
Indoor Unit Installation	8
Step 1 Checking and preparing accessories and tools	8
Step 2 Choosing the installation location	8
Step 3 Attaching the mounting bracket to the wall	10
Step 4 Drilling the wall penetration	11
Step 5 Purging the unit	12
Step 6 Cutting or flaring the pipes	12
Step 7 Connecting the refrigerant pipes	13
Step 8 Performing leak test	14
Step 9 Connecting the drain hose	15
Step 10 Connecting the power and communication cables	16
Step 11 Taping the pipes, cables, and drain hose	19
Step 12 Optional : Setting the Emergency Temperature Output (ETO) function	20
Step 13 Optional : Connecting the External control (MIM-B14), Wired Remote Control and External Floating switch	22
Step 14 Optional : LED Display indicator specifications when checking Wi-Fi Easy Setup and Wi-Fi status	23
Step 15 Setting the indoor unit addresses and the installation options	25
<b>Appendix</b>	<b>39</b>
Troubleshooting	39

# Safety Information

## California Proposition 65 Warning (US)

**WARNING:** Cancer and Reproductive Harm - [www.P65Warnings.ca.gov](http://www.P65Warnings.ca.gov).

**IMPORTANT** – This product has been designed and manufactured to meet ENERGY STAR criteria for energy efficiency when matched with appropriate coil components. However, proper refrigerant charge and proper air flow are critical to achieve rated capacity and efficiency. Installation of this product should follow the manufacturer's refrigerant charging and air flow instructions. Failure to confirm proper charge and airflow may reduce energy efficiency and shorten equipment life.

### WARNING







- Hazards or unsafe practices that may result in severe personal injury or death.

### CAUTION

- Hazards or unsafe practices that may result in minor personal injury or property damage.
- Carefully follow the precautions listed below because they are essential to guarantee the safety of the equipment.

### WARNING

- Always disconnect the air conditioner from the power supply before servicing it or accessing its internal components.
- Verify that installation and testing operations are performed by qualified personnel.
- Verify that the air conditioner is not installed in an easily accessible area.

Symbol	Meaning
	Flammable gas
	Flammable materials
	Refrigerant safety group
	Read installation manual
	Refer to installation manual
	Read service manual

### WARNING

The installation and testing of this appliance must be performed by a qualified technician.

- The instructions in this manual are not intended as a substitute for proper training or adequate experience in the safe installation of the appliance.

**Always install the air conditioner in compliance with current local, state, and federal safety standards.**

- Do not use means to accelerate the defrost operation or to clean, other than those recommended by Samsung.
- Do not pierce or burn.
- Be aware that refrigerants may not contain an odor.

## General information

### WARNING

- Carefully read the content of this manual before installing the air conditioner and store the manual in a safe place to be able to use it as a reference after installation.
- For maximum safety, installers should always carefully read the following warnings.



# Safety Information

- Store the operation and installation manual in a safe location and remember to hand it over to the new owner if the air conditioner is sold or transferred.
- This manual explains how to install an indoor unit with a split system with two SAMSUNG units. Using other types of units with different control systems may damage the units and invalidate the warranty. The manufacturer shall not be responsible for damages arising from the use of non-compliant units.
- The manufacturer shall not be responsible for damage from unauthorized changes or improper electrical connections. The requirements outlined in the "Operating limits" table, included in the manual, shall immediately invalidate the warranty.
- All pipe work including piping material, pipe routing, and installation shall include protection from physical damage in operation and service and comply with national and local codes and standards, such as ASHRAE 15, ASHRAE 15.2, IAPMO Uniform Mechanical Code, ICC International Mechanical Code, or CSA B52. Any field joints shall be accessible for inspection before being covered or enclosed.
- The air conditioner should be used only for the applications for which it has been designed: the indoor unit is not suitable to be installed in areas used for laundry.
- Do not use the units if damaged. If problems occur, switch the unit off and disconnect it from the power supply.
- To prevent electric shocks, fires or injuries, always stop the unit, disable the protection switch and contact SAMSUNG's technical support if the unit produces smoke, if the power cable is hot or damaged or if the unit is very noisy.
- Inspect the unit, electrical connections, refrigerant tubes and protections regularly. These operations should be performed by qualified personnel only.
- The unit contains moving parts, which should always be kept out of the reach of children.
- Do not attempt to repair, move, alter or reinstall the unit. If performed by unauthorized personnel, these operations may cause electric shocks or fires.
- Do not place containers with liquids or other objects on the unit.
- The air conditioner contains a refrigerant that must be disposed of as special waste. At the end of its life cycle, the air conditioner must be disposed of in authorized centers or returned to the retailer so it can be disposed of correctly and safely.
- Wear protective equipment (such as safety gloves, goggles, and headgear) during installation and maintenance work. Installation/repair technicians may be injured if protective equipment is not properly

equipped.

- This unit is a partial unit air conditioner, complying with partial unit requirements of this International Standard, and must only be connected to other units that have been confirmed as complying with corresponding partial unit requirements of this International Standard.
- This appliance is not intended for use by persons (including children) with reduced physical, sensory or mental capabilities, or lack of experience and knowledge unless they have been given supervision or instruction concerning the use of the appliance by a person responsible for their safety. Children should be supervised to ensure they do not play with the appliance.

## Installing the unit

### WARNING

**IMPORTANT: When installing the unit, always connect the refrigerant tubes first, and then the electrical lines.**

- Always disassemble the electric lines before the refrigerant tubes.
- Upon receipt, inspect the product to verify that it has not been damaged during transport. If the product appears damaged, DO NOT INSTALL it, and immediately report the damage to the carrier or retailer (if the installer or the authorized technician has collected the material from the retailer.)
- After completing the installation, always carry out a functional test and provide instructions on how to operate the air conditioner to the user.
- Do not use the air conditioner in environments with hazardous substances or close to equipment that releases free flames to avoid the occurrence of fires, explosions or injuries.
- Do not install the product on a ship or a vehicle (such as a campervan). Salt, vibration or other environmental factors may cause the product to malfunction, electric shock or fire.
- Excessive indoor humidity or clogged condensate drain lines may cause water to drip from indoor units. Do not install the indoor unit where dripping could result in property damage, such as over electronic equipment or other sensitive instruments.
- Our units must be installed in compliance with the space specifications presented in the installation manual to ensure accessibility from both sides and allow repairs or maintenance operations to be carried out. The unit's components must be accessible and easy to disassemble without endangering people and objects.





- For this reason, where it is not observed as indicated in the Installation Manual, the cost necessary to reach and repair the unit (safely as required by local regulations) with slings, trucks, scaffolding or any other means of elevation won't be considered in-warranty and charged to end user.
- If any gas or impurities, except R-32 refrigerant, come into the refrigerant pipe, a serious problem may occur and it may cause injury. Use the supplied accessories, specified components and tools for the installation.
  - Do not use the pipe and the installation product used for the R-22, R-410A refrigerant.
  - Failure to use the specified components can cause the product to fall, water leakage, electrical shock, and fire. (The pipe and flare components used for R-22, R-410A refrigerant must not be used)

## Power supply line, fuse or circuit breaker

### WARNING

- Always make sure that the power supply is compliant with current safety standards. Always install the air conditioner following current local safety standards.
- Always verify that a suitable grounding connection is available.
- Verify that the voltage and frequency of the power supply comply with the specifications and that the installed power is sufficient to ensure the operation of any other domestic appliance connected to the same electric lines.
- Always verify that the cut-off and protection switches are suitably dimensioned.
- Verify that the air conditioner is connected to the power supply following the instructions provided in the wiring diagram included in the manual.
- Always verify that electric connections (cable entry, section of leads, protections...) are compliant with the electric specifications and with the instructions provided in the wiring scheme. Always verify that all connections comply with the standards applicable to the installation of air conditioners.
- Devices disconnected from the power supply should be completely disconnected in the condition of overvoltage category.

### CAUTION

#### Make sure that you ground the cables.

- Do not connect the earth wire to the gas pipe, water pipe, lightning rod or telephone wire. If grounding is not complete, electric shock or fire may occur.

#### Install the circuit breaker.

- If the circuit breaker is not installed, electric shock or fire may occur.

#### Make sure that the condensed water dripping from the drain hose runs out properly and safely.

#### Install the power cable and communication cable of the indoor and outdoor unit at least 1m away from the electric appliance.

#### Install the indoor unit away from a lighting apparatus using the ballast.

- If you use the wireless remote control, reception error may occur due to the ballast of the lighting apparatus.
- If the supply cord is damaged, it must be replaced by the manufacturer, its service agent or similarly qualified persons to avoid a hazard.

#### Do not use the indoor unit for the preservation of food items, plants, equipment, and artwork. This may cause deterioration of their quality.

#### Do not install the indoor unit if it has any drainage problems.

## Precautions for using R-32 refrigerant

### General

- This product is pre-charged with mildly flammable gas classified as A2L by ASHRAE. The following precautions and instruction manuals must be followed during installation, operation, servicing and decommissioning of the product.
- The appliance shall be stored in a room without continuously operating ignition sources, like open flames or a gas appliance or an electric heater.
- All national and local regulations shall be observed at all times.
- All pipe-work including piping material, pipe routing and installation shall include protection from physical damage in operation and service, and comply with national and local codes and standards, such as ASHRAE 15, ASHRAE 15.2, IAPMO Uniform Mechanical Code, ICC International Mechanical Code, or CSA B52. All field joints shall be accessible for inspection before being covered or enclosed.
- All field piping and joints shall be pressure tested with an inert gas according to prevalent industry standards before refrigerant charging and system commissioning.
- Where additional field charging is required. The installer shall write with a permanent marker the field charge added on the ODU label provided, such that the Total Charge = Factory 'Pre-charge' + field charge.





# Safety Information

- Minimum floor area of the room shall be in compliance with the min. room area according to the total charge of the installation according to Table 1
- For ducted systems, any auxiliary systems that are potential ignition sources shall not be installed in the duct work. Examples of ignition sources are hot surfaces with temperatures exceeding 700°C and electric switching devices.
- Any auxiliary device installed must be approved by Samsung and must be suitable for operating with the refrigerant marked on the label.
- For mechanical ventilation the lower edge of the air extraction opening shall not be more than 100mm above the floor. The exhaust location outside the building must be at least 3 m away from the building opening and mechanical air intake openings.
- To handle, purge, and dispose of the refrigerant, or break into the refrigerant circuit, the worker should have a certificate from an industry-accredited authority.
- Non-ducted systems may be installed in areas such as false ceilings not being used as return air plenum if the conditioned air does not mix with the air in the false ceilings.
- For ducted appliances false ceilings or drop ceilings may be used as return air plenum if a refrigerant leak detection system is provided in the system and any external connections are also provided with a sensor immediately below the return air plenum duct joint.
- Installation, servicing, and any type of maintenance or repair must be performed by certified personnel who are competent to carry out such activity following national and local regulations.

- The work area should be checked to ensure that there are no flammable hazards or ignition risks. The "No Smoking" sign shall be attached.
- Under no circumstances shall potential sources of ignition be used upon detection of leakage.

The following checks shall be applied to installations and maintenance operations.

- The actual total refrigerant charge is in accordance with the room size in accordance with Table 1.
- The ventilation machinery and outlets are operating adequately and are not obstructed.
- Markings on the equipment are visible and legible.
- Refrigerant pipes or components are installed in a position where they are unlikely to be exposed to any substance that may corrode refrigerant containing components.

Initial checks of electrical devices shall include the following.

- that capacitors are discharged safely to avoid sparking.
- that no live electrical components and wiring are exposed while charging, recovering or purging the system.
- That there is continuity to earth bonding.
- Check that cabling is not worn, corroded or damaged in any manner.

## Electrical repair safety measures

- All electrical components used or replaced must be to Samsung's specifications.
- If a fault exists that could compromise safety, then no electrical supply shall be connected to the circuit until it is satisfactorily dealt with.
- Sealed electrical components and intrinsically safe components shall be replaced and not repaired.
- Cabling should be protected from excessive vibration, pressure, sharp edges, and other adverse environmental factors.

## Detection of flammable refrigerants

- Electronic leak detectors shall be used to detect flammable refrigerants, but the sensitivity may not be adequate or may need re-calibration. (Detection equipment shall be calibrated in a refrigerant-free area.)
- Make sure that the detector is not a potential source of ignition.
- Leak detection equipment shall be set at a percentage of the LFL (Lower flammable limit) of the refrigerant and shall be calibrated to the refrigerant employed and the appropriate percentage of gas (25% maximum) is confirmed.
- The use of detergents containing chlorine shall be avoided for cleaning because the chlorine may react with

## General information on Servicing

- Do not work in a confined space. Ensure adequate ventilation is provided at the workspace during the entirety of the duration of the work to safely disperse any released refrigerant.
- All maintenance staff and others working in the local area shall be instructed on the nature of the work being performed and instructed to follow all instructions provided by Samsung, national and local authorities.
- The area shall be checked with an approved refrigerant detector before and during any work on the system.
- Have a dry CO<sub>2</sub> fire extinguisher adjacent to the charging area and workspace.
- The service personnel shall not use any ignition sources in a manner that may lead to the risk of fire or explosion.
- Potential ignition sources shall be kept away from the work area where the flammable refrigerant can be released into the surrounding area.



the refrigerant and corrode the piping.

- If leakage is suspected, naked flames shall be removed.
- If a leakage is found while brazing, the entire refrigerant shall be recovered from the product or isolated (e.g. using shut-off valves). It shall not be directly released into the environment. Oxygen-free nitrogen (OFN) shall be used for purging the system before and during the brazing process.
- The work area shall be checked with an appropriate refrigerant detector before and during work.
- Ensure that the leakage detector is appropriate for use with flammable refrigerants.

## Removal and Evacuation

- When removing refrigerant for servicing it is recommended to remove the entire quantity.
- When removing refrigerant follow local and national regulations and follow best practices including;
  - evacuate;
  - purge the circuit with inert gas (optional for A2L);
  - evacuate (optional for A2L);
  - continuously flush or purge with inert gas when using a flame to open the circuit; and
  - open the circuit.
- Use proper recovery cylinders appropriate for the type of refrigerant.
- Follow prescribed industry best practices for purging and evacuation.
- Oxygen free nitrogen shall be used for purging the system.

## Charging procedure

- Follow industry standard refrigerant charging best practices.
- Before recharging the system shall be pressure tested with oxygen free nitrogen gas.
- Ensure that contamination of different refrigerants does not occur when charging.
- Cylinders shall be kept in the appropriate position as per instructions.
- The refrigerant system should be grounded before charging the system.
- Label the system when charging is completed.
- Take extreme care not to overfill the refrigeration system.
- The system shall be leak tested on completion of charging before commissioning.

## Decommissioning

- Only qualified licensed professionals shall perform refrigerant recovery and decommissioning.
- Isolate the system electrically.
- All recovery equipment and cylinders shall conform to appropriate standards. Only approved cylinders, with pressure relief valves, for the type of refrigerant shall be used.
- Recover refrigerant following industry standard procedure for flammable refrigerants.
- When draining compressors oil care must be taken that there is no flammable refrigerant in the compressor and that the compressor is not hot. Oil should be handled according to local and federal regulations.
- After decommissioning, the system shall be labeled stating that it has been decommissioned. The label shall be dated and signed. The label should state that it "contains flammable refrigerant".
- Ensure that there are labels on the equipment indicating the equipment contains flammable refrigerant.
- Recovered refrigerant shall not be mixed or reused. It shall be processed according to national, state and local regulations.
- Please cover the air conditioner with PE BAG after installation, and remove it when you start to run air conditioner.

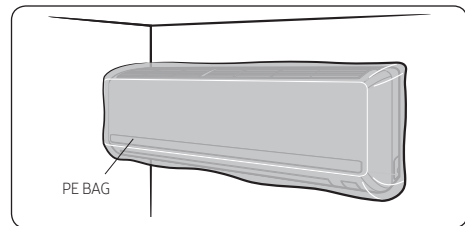





# Indoor Unit Installation

## Step 1 Checking and preparing accessories and tools

### Accessories

#### Accessories in the indoor unit package

Mounting bracket (1) 	User manual (1) 
Installation manual (1) 	PE indoor unit cover (1) 
Remote control (1) 	

### Tools

#### General tools

- Vacuum pump (Backward flowing prevention)
- Manifold gauge
- Stud finder
- Torque wrench
- Pipe cutter
- Reamer
- Pipe bender
- Spirit level
- Screwdriver
- Spanner
- Drill
- L-wrench
- Measuring tape

#### Tools for test operation

- Thermometer
- Resistance meter
- Electroscope

## Step 2 Choosing the installation location

### Installation location requirements

- There must be no obstacles near the air inlet and outlet.
- Install the indoor unit on a ceiling that can support its weight.
- Maintain sufficient clearance around the indoor unit.
- Before installing the indoor unit, be sure to check whether the chosen location is well-drained.
- The indoor unit must be installed such that it is beyond public access and is not touchable by users.
- A vibration-resistant location that is not inclined (If the indoor unit is installed on a structure that is not sturdy, it may fall and get damaged or cause injury.)
- Where it is not exposed to direct sunshine.
- Where the air filter can be removed and cleaned easily.
- A location where animals cannot access and urinate on the product. Ammonia may be generated.

### ⚠ WARNING

- Because your air conditioner contains R-32 refrigerant, make sure that it is installed, operated, and stored in a room whose floor area is larger than the minimum required floor area specified in the following table:

<Table 1>

m [lbs(kg)]	Minimum required room area [A, ft <sup>2</sup> (m <sup>2</sup> )]	
	Reference Height [h <sub>r</sub> , ft(m)]	
	Wall-mounted (without R-32 sensor)	
	5.91(1.8)	
≤ 4.047(1.836)	- no room area restrictions -	
4.049(1.837)	71.8(6.67)	
4.18(1.9)	74.3(6.90)	
4.40(2.0)	78.2(7.26)	
4.85(2.2)	86.0(7.99)	
5.29(2.4)	93.8(8.71)	
5.73(2.6)	102(9.44)	
6.17(2.8)	109(10.2)	
6.61(3.0)	117(10.9)	
7.05(3.2)	125(11.6)	
7.49(3.4)	133(12.3)	
7.93(3.6)	141(13.1)	
8.37(3.8)	149(13.8)	
8.81(4.0)	164(15.3)	
9.25(4.2)	181(16.8)	
9.70(4.4)	199(18.5)	
10.14(4.6)	217(20.2)	
10.58(4.8)	236(22.0)	
11.02(5.0)	257(23.8)	
11.46(5.2)	277(25.8)	
11.9(5.4)	299(27.8)	



- m : Total refrigerant charge in the system
- A : Minimum required floor area
- Calculated in accordance with UL 60335-2-40 Annex GG

- **IMPORTANT:** It's mandatory to either follow the table above or follow the federal, state, and/or local regulations regarding the minimum room area allowed for the total refrigerant charge in the system.
- The actual refrigerant charge shall be per the room size within which the refrigerant-containing parts are installed.
- The ventilation machinery and outlets shall be operating adequately and not obstructed.
- If an indirect refrigerating circuit is being used, the secondary circuit shall be checked for the presence of refrigerant.
- Marking the equipment shall continue to be visible and legible. Markings and signs that are illegible shall be corrected.
- Refrigerating pipes or components shall be installed in a position where they are unlikely to be exposed to any substance that may corrode refrigerant-containing components unless the components are constructed of materials that are inherently resistant to being corroded or are suitably protected against being so corroded.

- The copper pipe or connection pipe may corrode and the refrigerant may leak.
- The place where there is a machine that generates electromagnetic waves. The air conditioner may not operate normally due to the control system.
- The place where there is a danger of existing combustible gas, carbon fiber or flammable dust.
- The place where thinner or gasoline is handled. Gas may leak and it may cause fire.
- The place that is close to heat sources.
- Do not use the indoor unit for the preservation of food items, plants, equipment, and artwork. This may cause deterioration of their quality.
- Do not install the indoor unit if it has any drainage problems.

### CAUTION

- As a rule, the unit cannot be installed at a height of less than 5.91 ft(1.8 m).
- If you install a cassette type indoor unit on the ceiling when the temperature is over 80.6°F (27°C) and humidity is over 80%, you must apply an extra 0.39inch (10mm) thick polyethylene insulation or a similar type of insulation to the body of the indoor unit.

### Do not install the air conditioner in the following places.

- A place where there is mineral oil or arsenic acid. resin parts flame and the accessories may drop, or water may leak. The capacity of the heat exchanger may be reduced, or the air conditioner may be out of order.
- A place with exposure to mineral oil, oil vapor or a cooking area where there is spray (If oil adheres to the heat exchanger, performance degradation, spray or condensation scattering may occur. If oil adheres to a plastic component, the component may deform or get damaged. Such issues may result in a system failure or refrigerant leak.)
- A place with aromatic diffusers, aromatherapy, scented candles or perfumes as the chemicals may react to the product's materials and may result in system failure or refrigerant leaks.
- The place where corrosive gas such as sulphuric acid gas is generated from the vent pipe or air outlet.



# Indoor Unit Installation

## Overview of installation location requirements

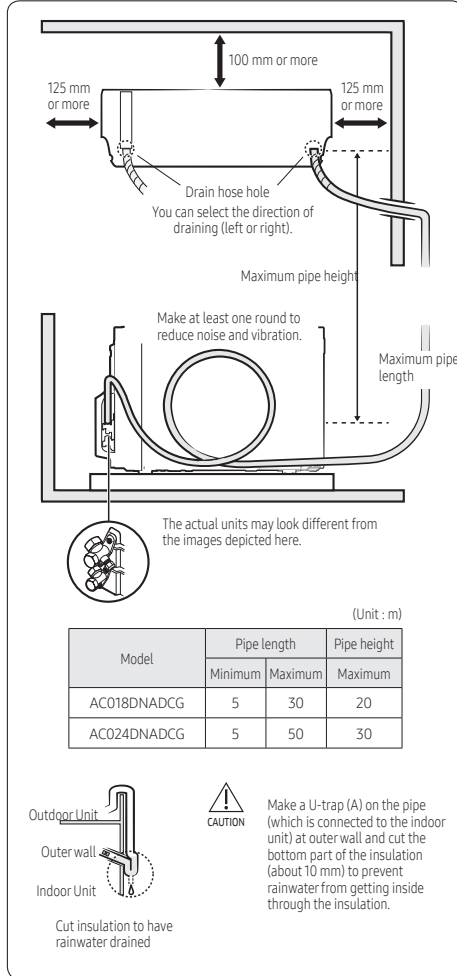

### NOTE

- The appearance of the unit may be different from the diagram depending on the model.

### CAUTION

- Comply with the length and height limits described in the figure above.
- For the product that uses the R-32 refrigerant, Install the indoor unit on the wall 1.8 m or higher from the floor.

## Step 3 Attaching the mounting bracket to the wall

- Hold the mounting bracket against the wall at the selected installation position (in Step 2), making sure that the screw holes align with the center of the studs in the wall. If the screw locations do not align with the studs, use wall anchors.

### CAUTION

- The recommended best practice is to attach the mounting bracket directly to the studs in the wall. If you did not find a suitable location with studs (in Step 2), or if the wall is concrete, you must use wall anchors of a suitable type and weight capacity, and install them according to the manufacturer's instructions. Failure to do so may cause the material surrounding the joints to crumble over time and the screws to be loosened and stripped. This may result in the unit falling from the wall, which could cause physical injury or equipment damage.
- Using a level, make sure that the mounting bracket is level, then mark the location of the screw holes on the wall.
  - If using wall anchors, install them at the screw hole positions, following the manufacturer's instructions.
  - Using six field-supplied mounting screws and anchors (if applicable), attach the bracket to the wall.

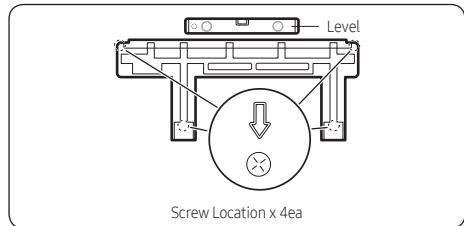

## Step 4 Drilling the wall penetration

- 1 Determine the position of the hole through which the piping bundle (consisting of power and communication cables, refrigerant pipes, and the drain hose) will pass. Consider the following:
  - The hole inner diameter must be 2.56 inch (65mm).
  - The recommended hole location is behind the unit so that the hole and the piping bundle will not be visible in the room. The minimum distances between the hole and the mounting bracket are:

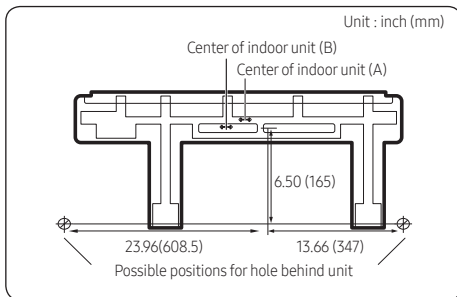

- If the hole cannot be positioned behind the unit, find a position as close to the unit as possible. The piping bundle that exits the unit and extends to the hole will need to be attached to the wall and will be visible inside the room.
- In relation to the bracket shown above, the unit is shipped with the drain hose connection on the right, the drain hose exits the unit on the left, and the refrigerant pipes are bent to exit on the left. Thus, positioning the hole to the left requires the least effort. If you position the hole to the right or below the unit, you will need to move the drain hose connection to the left and bend the pipes so that the hose and pipes exit to the right or bottom. See the figure in Step 7.

- 2 Use a standard 2.56 inch(65mm) hole saw to drill one hole at the selected location, at a 15° downward angle so that the drain hose will drain properly.

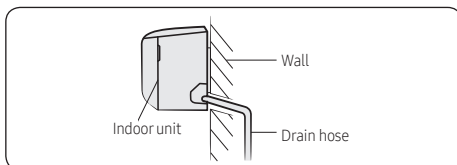

- 3 Based on the hole location, determine where the piping bundle (drain hose, refrigerant pipes, and cables) will exit the unit.

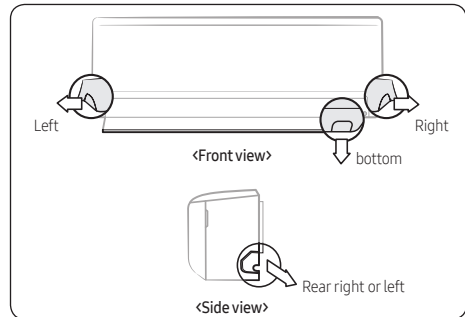

### NOTE

- The left, right, or bottom exit will only be used if the hole is not positioned behind the unit.

# Indoor Unit Installation

## Step 5 Purging the unit

Upon delivery, there may be inert gas inside the indoor unit. Purge the gas from the indoor unit before connecting the assembly pipe.

- Unscrew the caps at the end of each pipe. All inert gas exhausts from the indoor unit.

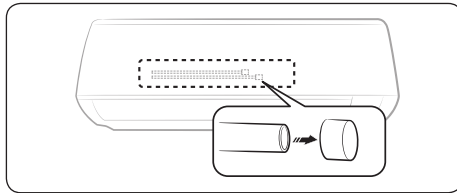

### NOTE

- To prevent dirt or foreign substances from getting into the pipes during installation, do NOT remove the caps completely until you are ready to connect the pipes

- 4 Carry out flaring work using flaring tool as shown below.

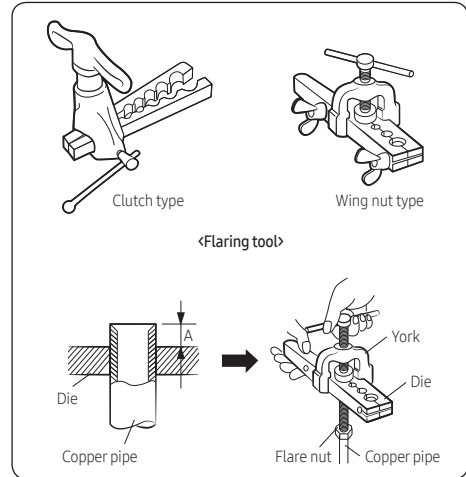

## Step 6 Cutting or flaring the pipes

- 1 Make sure that you prepared the required tools. (pipe cutter, reamer, flaring tool and pipe holder)
- 2 If you want to shorten the pipe, cut it using a pipe cutter ensuring that the cut edge remains at 90° with the side of the pipe. There are some examples of correctly and incorrectly cut edges below.

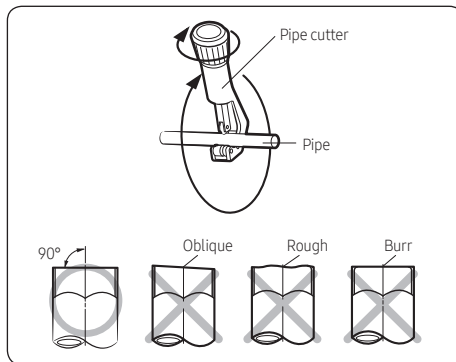

- 3 To prevent a gas leak, remove all burrs at the cut edge of the pipe using a reamer.

(Unit: inch (mm))

Outer diameter	A		
	Flare tool for R-32 clutch type	Conventional flare tool	
		Clutch type	Wing nut type
Ø1/4 inch (6.35 mm)	0~0.02 (0~0.5)	0.04~0.06 (1.0~1.5)	0.06~0.08 (1.5~2.0)
Ø3/8 inch (9.52 mm)	0~0.02 (0~0.5)	0.04~0.06 (1.0~1.5)	0.06~0.08 (1.5~2.0)
Ø1/2 inch (12.70 mm)	0~0.02 (0~0.5)	0.04~0.06 (1.0~1.5)	0.06~0.08 (1.5~2.0)
Ø5/8 inch (15.88 mm)	0~0.02 (0~0.5)	0.04~0.06 (1.0~1.5)	0.06~0.08 (1.5~2.0)

- 5 Check if you flared the pipe correctly. There are some examples of incorrectly flared pipes below.

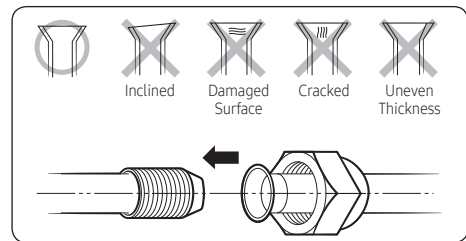

- 6 Align the pipes and tighten the flare nuts first manually and then with a torque wrench, applying the following torque.

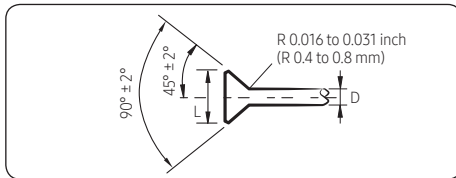

Outer diameter, D (inch (mm))	Connection Torque		Flare dimension, L (inch(mm))
	kgf•cm	(lbf•ft (N•m))	
Ø1/4 inch (6.35 mm)	140~180	10.3 to 13.3 (14 to 18)	0.34 to 0.36 (8.7 to 9.1)
Ø3/8 inch (9.52 mm)	350~430	25.1 to 31.0 (34 to 42)	0.50 to 0.52 (12.8 to 13.2)
Ø1/2 inch (12.70 mm)	500~620	36.1 to 45.0 (49 to 61)	0.64 to 0.65 (16.2 to 16.6)
Ø5/8 inch (15.88 mm)	690~830	50.2 to 60.5 (68 to 82)	0.76 to 0.78 (19.3 to 19.7)

### CAUTION

- In case of needing brazing, you must work with nitrogen gas blowing.

## Step 7 Connecting the refrigerant pipes

Connect the indoor and outdoor units using pipes with flared connections (not supplied). For the lines, use insulated, unwelded, degreased and deoxidized copper pipe (Cu DHP type to ISO 1337 or UNI EN 12735-1). Operating pressure depends on outdoor unit specifications. Check the outdoor unit installation manual. Copper pipes for hydro-sanitary applications are completely unsuitable.

For sizing and limits (height difference, line length, max. bends, refrigerant charge, etc.) see the outdoor unit installation manual. All refrigerant connections must be accessible, to permit either unit maintenance or removing it completely. If the pipes require brazing, make sure that oxygen free nitrogen (OFN) is flowing through the system. The nitrogen blowing pressure range is 0.02 to 0.05 MPa (2.9 to 7.3 psi).

### IMPORTANT

- When installing the unit, always connect the refrigerant pipes first, followed by the electrical cables. For disassembly, always disassemble the electric cables before the refrigerant pipes.

Two short refrigerant pipes are already attached to the air conditioner:

- The smaller-diameter pipe is for the high-pressure, two-phase refrigerant.
- The larger-diameter pipe is for the low-pressure refrigerant vapor.

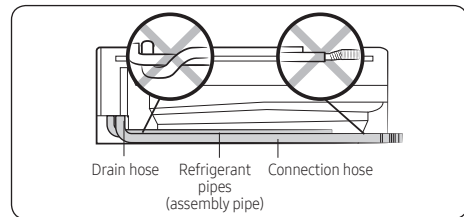

In Step 4 you determined the exit position for the piping bundle. The unit has three knockouts available for the left, right, and bottom exits. When the bundle exits directly from the rear, none of the knockouts are used.

- If the pipes will exit directly from the rear, skip to step 3. Otherwise, cut out the appropriate knockout piece (left, right, or bottom).
- Use a razor knife to clean the cut edges (flashing).
- The left exit is the only position that does not require bending the pipes. For other positions, bend the pipes so that they will exit in the selected exit position.
  - The bending radius should be greater than 100 mm.
  - Bend the smaller pipe gradually to prevent kinking. The larger pipe has a preinstalled spring bender to prevent kinking.
  - Make sure that the pipes do not protrude from the back of the unit in a way that will make it difficult to attach the unit to the mounting bracket.
  - For right and bottom exits, pull the pipes out through the selected knockout opening. For left exits, the piping connections will be made in the service space behind the indoor unit (under the cover panel).

# Indoor Unit Installation

## NOTE

- If you are using the right rear exit, the pipes should be long enough to extend through the wall without needing to connect the line set first. It may be easier to connect the line set outside of the building, after you have bundled the pipes and cables and passed the bundle through the wall. In this case, do not connect the line set now. Instead, complete Step 9 through Step 12, then go outside and connect the line set as described below.

- Slowly remove the protective caps on the refrigerant pipe connections to relieve the nitrogen holding charge.
- Connect the line set to each pipe.

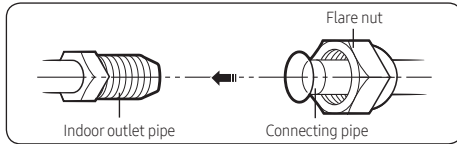

- Hand-tighten the flare nuts to make sure that they do not become stripped.

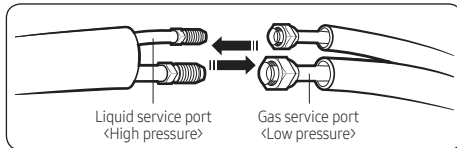

- Torque the flare connections to the following values:

Outer diameter (inch (mm))	Torque (lb•ft (N•m))	Torque (kgf•cm)
Ø 1/4" (6.35)	10.3 to 13.3 (14 to 18)	140~180
Ø 3/8" (9.52)	25.1 to 31.0 (34 to 42)	350~430
Ø 1/2" (12.70)	36.1 to 45.0 (49 to 61)	500~620
Ø 5/8" (15.88)	50.2 to 60.5 (68 to 82)	690~830

## CAUTION

- Tighten the flare nuts only to the specified torque. If a flare nut is overtightened, the flare face may crack, causing refrigerant leakage.
- Do not box in or cover the pipe connections. Make sure that the connections are accessible for testing later in the installation process and for future servicing.

- Tape over the end of the pipes so that debris will not enter the piping when it is passed through the wall. The pipes will be insulated later in the installation process.

## Step 8 Performing leak test

### Leak test

To identify potential gas leaks in the indoor unit, inspect the connection area of each refrigerant pipe using a leak detector for R-32. Before creating a vacuum and adding refrigerant, pressurize the whole system with nitrogen using a cylinder with a pressure reducer at a pressure above 0.2 MPa(29.0 psi), less than 4.0 Mpa(580.0 psi) (gauge) to detect leaks on the refrigerant fittings. Refer to the outdoor unit installation manual for the complete steps for pressure testing and vacuuming the system before charging with refrigerant.

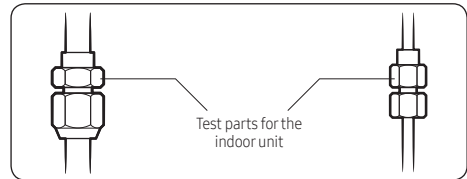

## CAUTION

- Discharge all the nitrogen to create a vacuum and charge the system.

## Step 9 Insulating the refrigerant pipes

Once you have checked that there are no leaks in the system, you can insulate the piping and hose.

- To avoid condensation problems, place Acrylonitrile Butadiene Rubber separately around each refrigerant pipe.

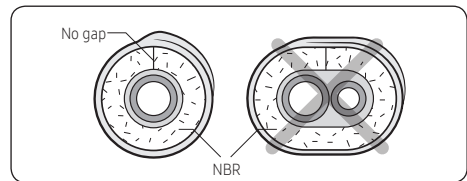

## NOTE

- Always make the seam of pipes face upwards.

## Step 9 Connecting the drain hose

- 1 In Step 4 you determined the exit position for the piping bundle. If using the right, bottom, or right rear exit, change the drain hose connection from the right to the left so that the drain hose will lie along the inside of the unit and exit to the right.

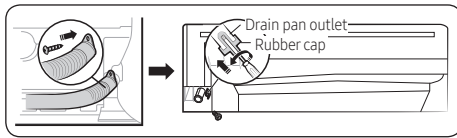

### CAUTION

- Be careful not to puncture the plug with the screwdriver when installing it.
- 2 If using the left, right, or bottom exit, pass the drain hose through the selected knockout.

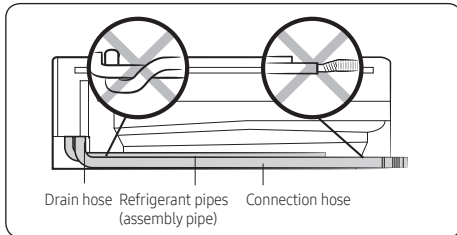

- 3 Connect a 0.63inch (15.88mm) ID extension drain hose to the main drain hose.

### CAUTION

- If the diameter of the connection hose is smaller than the product's drain hose, leakage may occur.

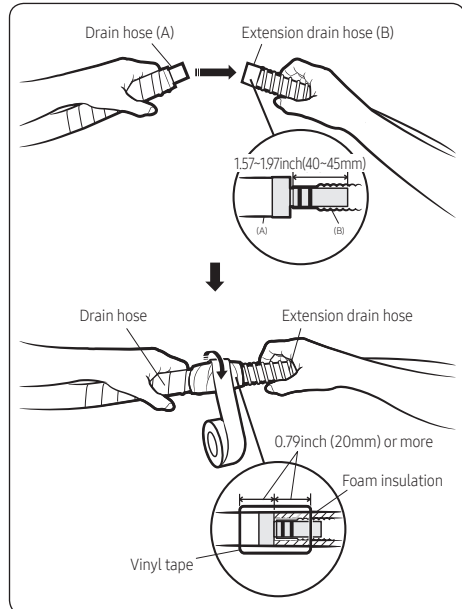

- 4 Do not box in or cover the drain hose connection. It must be accessible for testing later in the installation process and for future servicing.
- 5 If the drain hose is routed inside the room, insulate the hose so that dripping condensation does not damage the furniture or floors.

# Indoor Unit Installation

## Step 10 Connecting the power and communication cables

### ⚠ CAUTION

- Always remember to connect the refrigerant pipes before performing the electric connections. When disconnecting the system, always disconnect the electric cables before disconnecting the refrigerant pipes.
- For the product that uses the R-32 refrigerant, be cautious not to generate a spark by keeping the following requirements:
  - Do not remove the fuses with power on.
  - Do not disconnect the power plug from the wall outlet with power on.
  - It is recommended to locate the outlet in a high position. Place the cords so that they are not tangled.
- Always remember to connect the air conditioner to the grounding system before performing the electric connections. Use a crimp ring terminal at the end of each wire.

The indoor unit is powered through the outdoor unit by means of a H05RN-F (60245 / IEC57) connection cable (or a more power model), with insulation in synthetic rubber and a jacket in polychloroprene (neoprene), in accordance with the requirements specified in the standard EN 60335-2-40.

- 1 Remove the screw on the electrical component box and remove the cover plate.
- 2 Route the connection cord through the side of the indoor unit and connect the cable to the terminals refer to the figure below.
- 3 Route the other end of the cable to the outdoor unit through the ceiling & the hole on the wall.
- 4 Reassemble the electrical component box cover, carefully tightening the screw.

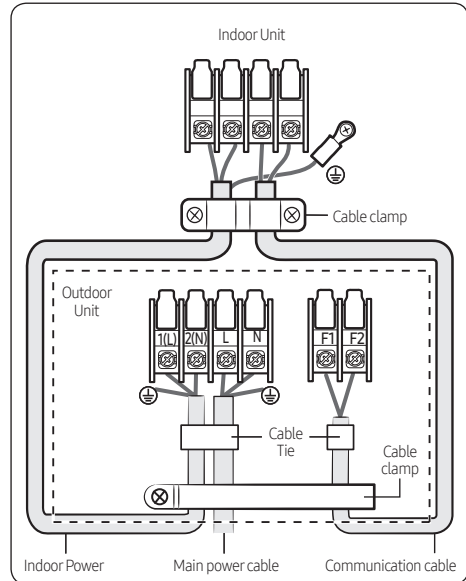

Indoor power supply		
Power supply	Max/ Min(V)	Indoor power cable
208 to 230V, 60Hz	±10%	AWG18↑, 3 wires
Communication cable		
AWG18↑, 2 wires		

(Unit: inch (mm))

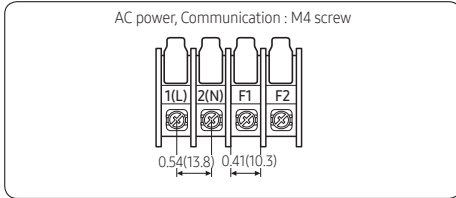

	Tightening torque	
	N·m	lbf.ft
M3.5	0.8 to 1.2	0.59 to 0.89
M4	1.2 to 1.8	0.89 to 1.1

(1N·m=10kgf·cm)

- Power supply cords of parts of appliances for outdoor use shall not be lighter than polychloroprene sheathed flexible cords. – Code designation [1-phase] IEC: 60245 IEC 57 / CENELEC: H05RN-F grade or more
- Since it has the external power supply, refer to the outdoor unit installation manual for MAIN POWER.

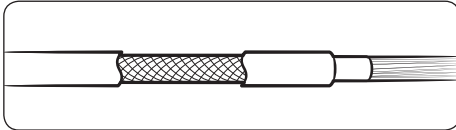

### CAUTION

- When installing the indoor unit in a computer room or network room, use the double shielded communication cable (tape aluminum / polyester braid + copper) of FROHH2R or LiYCY type.

# Indoor Unit Installation

## Wiring work

### Selecting compressed ring terminal

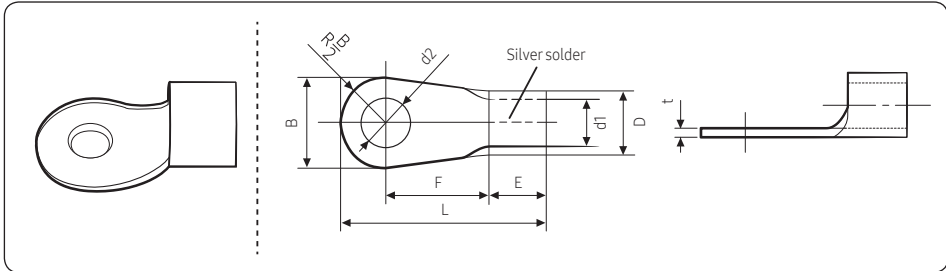

Nominal dimensions for cable [Inch <sup>2</sup> (mm <sup>2</sup> )]		0.002 (1.5)		0.003 (2.5)		0.006 (4)
Nominal dimensions for screw [Inch (mm)]		0.15 (4)	0.15 (4)	0.15 (4)	0.15 (4)	0.15 (4)
B	Standard dimension [Inch (mm)]	0.25 (6.6)	0.31 (8.0)	0.25 (6.6)	0.33 (8.5)	0.37 (9.5)
	Allowance [Inch (mm)]	±0.007 (±0.2)		±0.007 (±0.2)		±0.007 (±0.2)
D	Standard dimension [Inch (mm)]	0.13 (3.4)		0.16 (4.2)		0.22 (5.6)
	Allowance [Inch (mm)]	+0.011 (+0.3) -0.007 (-0.2)		+0.011 (+0.3) -0.007 (-0.2)		+0.011 (+0.3) -0.007 (-0.2)
d1	Standard dimension [Inch (mm)]	0.06 (1.7)		0.09 (2.3)		0.13 (3.4)
	Allowance [Inch (mm)]	±0.007 (±0.2)		±0.007 (±0.2)		±0.007 (±0.2)
E	Min. [Inch (mm)]	3/16 (4.1)		1/4 (6)		1/4 (6)
F	Min. [Inch (mm)]	1/4 (6)		1/4 (6)		1/4 (6)
L	Max. [Inch (mm)]	5/8 (16)		3/4 (17.5)		3/4 (20)
d2	Standard dimension [Inch (mm)]	0.16 (4.3)		0.16 (4.3)		0.16 (4.3)
	Allowance [Inch (mm)]	+0.007 (+0.2) 0 (0)		+0.007 (+0.2) 0 (0)		+0.007 (+0.2) 0 (0)
t	Min. [Inch (mm)]	0.02 (0.7)		0.03 (0.8)		0.035 (0.9)

## Step 11 Taping the pipes, cables, and drain hose

- 1 Wrap foam insulation around the refrigerant pipes, up to the connection points. The connections must remain accessible for testing later in the installation process. Either leave slits in the insulation or do not cover the connections.

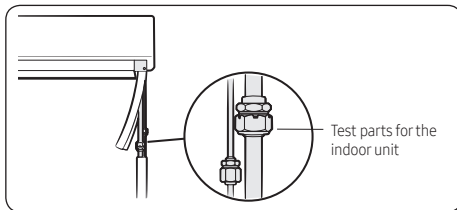
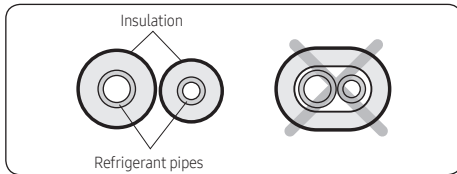

- 2 Make a piping bundle by using vinyl tape to wrap together the refrigerant pipes, power cable, communication cable, and drain hose, up to the connection points. Connection points must remain accessible for testing later in the installation process.

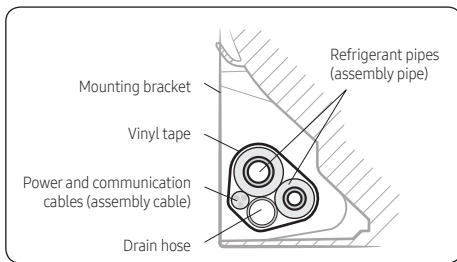

# Indoor Unit Installation

## Step 12 Optional : Setting the Emergency Temperature Output (ETO) function

### Emergency Temperature Output (ETO) function

#### CAUTION

- In order to deploy the ETO function, the MIM-B14 or MIM-B14U, an external contact interface module, must be installed in each indoor unit.
  - To use the ETO function, should use S-NET Pro 2.
  - The ETO is a concept of emergency operation of indoor units. If the indoor unit 1 (main indoor unit) stops because of an error, the indoor unit 2 (sub indoor unit) starts to operate.
  - Basically, the indoor unit 2 operates in the previous mode. [For the first time operation, it starts in 24 °C (75 °F) Auto mode.]
  - To set more detailed operation conditions for the indoor unit 2, use the S-net Pro 2.

### Setting up the ETO

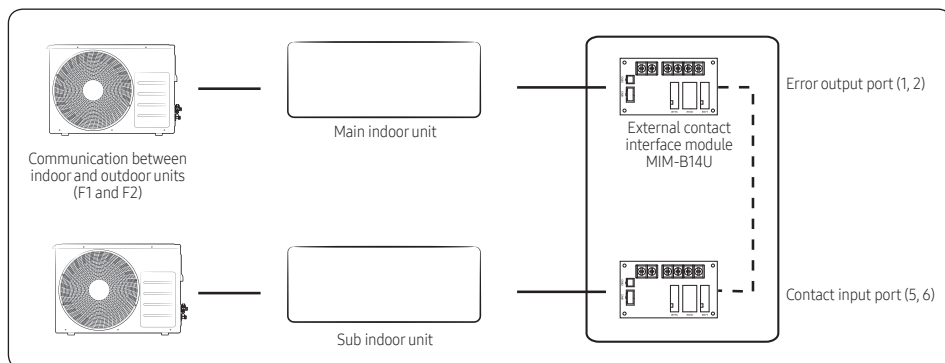

- 1 Main indoor unit
  - Disable the external contact control (Default).
  - Connect the S-net Pro 2. to F1 and F2.
  - Enable the ETO function and set the temperature and time.
- 2 Sub indoor unit
  - (Required) Enable the external contact control (with the installation option SEG14 - Reverse Control).
  - Connect the S-net Pro 2. to F1 and F2.
  - Enable the entrance control and set the mode, set temperature, and fan speed.

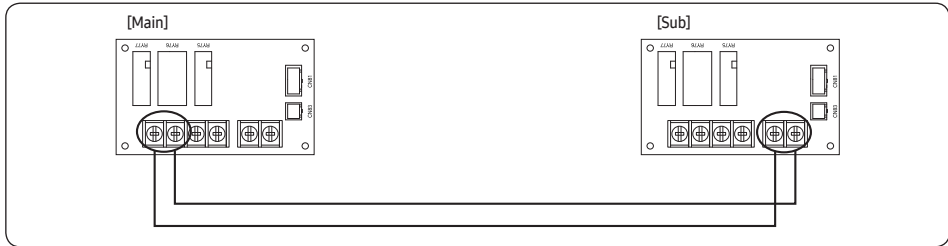

## ETO operation specifications

### 1 Main indoor unit

- Based on the external contact control settings, the main indoor unit decides whether to generate output when an error (indoor unit stop) occurs.
- Based on the ETO settings, the main indoor unit decides whether to generate output according to the temperature and time conditions.

### 2 Sub indoor unit

- Based on the entrance control settings, the sub indoor unit decides the mode, set temperature, and fan speed when contact inputs are given.

	Enable of ETO	Enable of external contact	Error port output
Main indoor unit	X	X	N/A
	X	O	Output due to an error
	O	X	Output by ETO entrance conditions (temperature / time / error occurrence)
	O	O	Output by ETO entrance conditions (temperature / time / error occurrence) ※ Ready to control the main contact input

	Enable of entrance control	Enable of external contact	Operation when outputting Main
Sub indoor unit	X	X	N/A
	X	O	On with the previous operation conditions
	O	O	On with the entrance control enabled

# Indoor Unit Installation

## Step 13 Optional : Connecting the External control (MIM-B14U), Wired Remote Control and External Floating switch

After disassembling the cover panel, you can connect the wires from the indoor unit's display to the External control(MIM-B14U) and wired remote control, External floating switch.

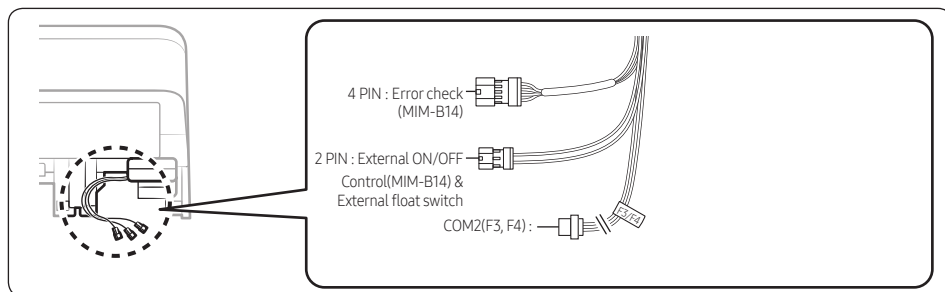





- External controller (MIM-B14U) : Connect the wires of the external controller to 4 PIN wire (Error check) and 2 PIN wire (External On/Off). (Refer to the manual of MIM-B14U.)  
Next, set SEG15 for the Install option (02 mode). (See step 15 for details on how to set an option code.)
- Wired Remote control : Be sure to connect the wired remote control for installation after cutting the COM2 wire.
- Connecting the External Floating switch :
  1. Connect the external float switch to the 2PIN wire.
  2. If the connector types of the external float switch and 2PIN wire do not match, cut off the end of the 2PIN wire before connecting the wire to the external float switch.
  3. Set SEG8 for the Install option (02 mode) to '8'. (Refer to "Setting an indoor unit installation option")

### NOTE

- The External Floating switch is not sold separately by Samsung.
- External Control (MIM-B14U) and External Floating switch cannot be connected simultaneously. Only either of them can be connected at a time.

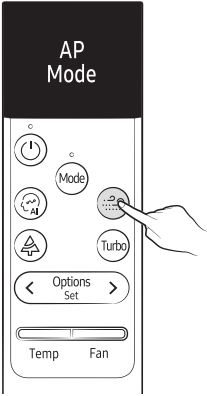
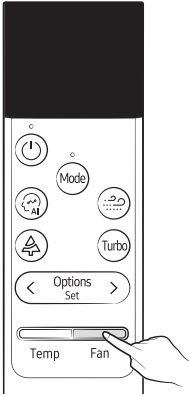
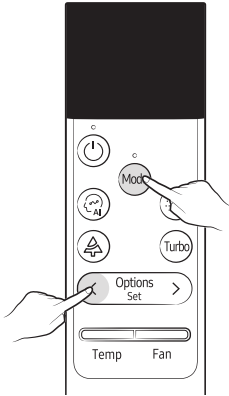
## Step 14 Optional : LED Display indicator specifications when checking Wi-Fi Easy Setup and Wi-Fi status

The wireless remote control can be used for Easy Setup, checking the internet connection status and connecting or disconnecting Wi-Fi.

Easy Setup	Check internet connection status	Enable/Disable Wi-Fi
		
<p>Press the  button for 5 seconds</p>	<p>Press the  button for 5 seconds</p>	<p>Press the  and  button for 5 seconds</p>

# Indoor Unit Installation

## LED Indicator Status

		LED Indicators on the temperature indicator	Wi-Fi LED	Remarks	Action to take
Easy Setup	AP mode activation and device connection	AP		Displays 'AP' On standby for 5 minutes before connection.	-
	Device authentication (or automatic AP mode activation)			Displays 'AP' blinks On standby for 3 minutes before connection.	-
	AP mode activation failure	FA		Displays 'FA' for 10 sec., and return to the state before AP connection	Try again the AP mode activation step
	Device checking and mobile connection	BB		LEDs turns clockwise and blinks	-
	Connected	BB		Blinks for 3 sec., and then the Wi-Fi LED lights up	-
	Connection failed	AP		Displays 'AP' for 5 sec., and return to the state before AP connection	Try again the AP mode activation step
Wi-Fi function	Enable	75		Displays the current or set temperature. The Wi-Fi LED lights off.	-
	Disable			Displays the current or set temperature. The Wi-Fi LED turns off.	-
Initialize connection information		rS		Displays 'rS' blinks for 2 sec., and displays the current or set temperature.	-
Initialize the device		CL		Displays 'CL' blinks for 3 sec., and displays the current or set temperature.	-

## Step 15 Setting the indoor unit addresses and the installation options

You cannot set both indoor unit addresses and the installation options in a batch: set both respectively.

### Common steps for setting the addresses and options

#### Remote controls

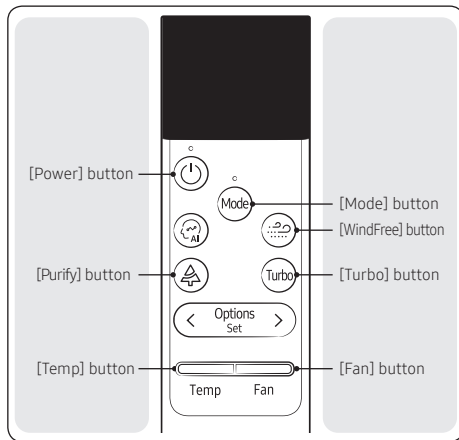

#### NOTE

- The remote control display and buttons may vary depending on the model.
- Enter the mode for setting the options.
    - Reset remote control: button Down + button Down + Press for 10 seconds
    - You can see the "SW Initialization" message and enter the following in 5 seconds.
    - Press button and button for 5 seconds.

- Make sure that you are entered to the mode for setting options.

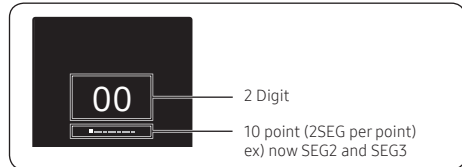

- Set the option values.

#### CAUTION























- The total number of available options are 24 : SEG1 to SEG24
- Because SEG1, SEG7, SEG13 and SEG19 are the page options used by the previous remote control models, the modes to set values for these options are skipped automatically.
- Set a 2-digit value for each option pair in the following order.
- You can see 20 SEG ( except SEG1, SEG7, SEG13, SEG19) SEG2 → ... → SEG6 → SEG8 → ..... → SEG12 → SEG14 → .... → SEG18 → SEG20 → ... → SEG24

SEG1	SEG2	SEG3	SEG4	SEG5	SEG6
0	X	X	X	X	X
SEG7	SEG8	SEG9	SEG10	SEG11	SEG12
1	X	X	X	X	X
SEG13	SEG14	SEG15	SEG16	SEG17	SEG18
2	X	X	X	X	X
SEG19	SEG20	SEG21	SEG22	SEG23	SEG24
3	X	X	X	X	X





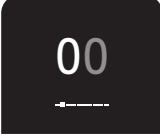
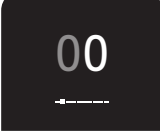

















- You can set the next SEG by pressing the button.
- You can change the digit value through the following operation.  
 Left value: up or down, range : 0 ~ F  
 Right value: up or down, range : 0 ~ F

# Indoor Unit Installation

Take the steps presented in the following table:



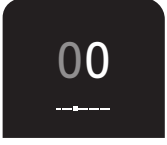





















Steps	Remote control display
<p><b>1</b> Set the SEG2 and SEG3 values:</p> <p><b>a</b> Set the SEG2 value by pressing the  button repeatedly until the value you want to set appears on the remote control display.</p> <p><b>b</b> Set the SEG3 value by pressing the  button repeatedly until the value you want to set appears on the remote control display.</p> <p>When you press the  or  button, values appear in the following order:   →  → ... →  → </p>	 SEG2  SEG3
<p><b>2</b> Press the  button to move to the next page.</p>	
<p><b>3</b> Set the SEG4 and SEG5 values:</p> <p><b>a</b> Set the SEG4 value by pressing the  button repeatedly until the value you want to set appears on the remote control display.</p> <p><b>b</b> Set the SEG5 value by pressing the  button repeatedly until the value you want to set appears on the remote control display.</p> <p>When you press the  or  button, values appear in the following order:   →  → ... →  → </p>	 SEG4  SEG5
<p><b>4</b> Press the  button to move to the next page.</p>	





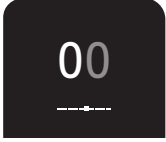





















Steps	Remote control display
<p><b>5</b> Set the SEG6 and SEG8 values:</p> <p><b>a</b> Set the SEG6 value by pressing the  button repeatedly until the value you want to set appears on the remote control display.</p> <p><b>b</b> Set the SEG8 value by pressing the  button repeatedly until the value you want to set appears on the remote control display.</p> <p>When you press the  or  button, values appear in the following order:   →  → ... →  → </p>	 <p>SEG6</p>  <p>SEG8</p>
<p><b>6</b> Press the  button to move to the next page.</p>	
<p><b>7</b> Set the SEG9 and SEG10 values:</p> <p><b>a</b> Set the SEG9 value by pressing the  button repeatedly until the value you want to set appears on the remote control display.</p> <p><b>b</b> Set the SEG10 value by pressing the  button repeatedly until the value you want to set appears on the remote control display.</p> <p>When you press the  or  button, values appear in the following order:   →  → ... →  → </p>	 <p>SEG9</p>  <p>SEG10</p>
<p><b>8</b> Press the  button to move to the next page.</p>	



# Indoor Unit Installation





















Steps	Remote control display
<p><b>9</b> Set the SEG11 and SEG12 values:</p> <p><b>a</b> Set the SEG11 value by pressing the  button repeatedly until the value you want to set appears on the remote control display.</p> <p><b>b</b> Set the SEG12 value by pressing the  button repeatedly until the value you want to set appears on the remote control display.</p> <p>When you press the  or  button, values appear in the following order:   →  → ... →  → </p>	 <p>SEG11</p>  <p>SEG12</p>
<p><b>10</b> Press the  button to move to the next page.</p>	
<p><b>11</b> Set the SEG14 and SEG15 values:</p> <p><b>a</b> Set the SEG14 value by pressing the  button repeatedly until the value you want to set appears on the remote control display.</p> <p><b>b</b> Set the SEG15 value by pressing the  button repeatedly until the value you want to set appears on the remote control display.</p> <p>When you press the  or  button, values appear in the following order:   →  → ... →  → </p>	 <p>SEG14</p>  <p>SEG15</p>
<p><b>12</b> Press the  button to move to the next page.</p>	



Steps	Remote control display
<p><b>13</b> Set the SEG16 and SEG17 values:</p> <p><b>a</b> Set the SEG16 value by pressing the  button repeatedly until the value you want to set appears on the remote control display.</p> <p><b>b</b> Set the SEG17 value by pressing the  button repeatedly until the value you want to set appears on the remote control display.</p> <p>When you press the  or  button, values appear in the following order:   →  → ... →  → </p>	 SEG16  SEG17
<p><b>14</b> Press the  button to move to the next page.</p>	
<p><b>15</b> Set the SEG18 and SEG20 values:</p> <p><b>a</b> Set the SEG18 value by pressing the  button repeatedly until the value you want to set appears on the remote control display.</p> <p><b>b</b> Set the SEG20 value by pressing the  button repeatedly until the value you want to set appears on the remote control display.</p> <p>When you press the  or  button, values appear in the following order:   →  → ... →  → </p>	 SEG18  SEG20
<p><b>16</b> Press the  button to move to the next page.</p>	

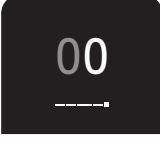

# Indoor Unit Installation

Steps	Remote control display
<p><b>17</b> Set the SEG21 and SEG22 values:</p> <p><b>a</b> Set the SEG21 value by pressing the  button repeatedly until the value you want to set appears on the remote control display.</p> <p><b>b</b> Set the SEG22 value by pressing the  button repeatedly until the value you want to set appears on the remote control display.</p> <p>When you press the  or  button, values appear in the following order:   →  → ... →  → </p>	 <p>SEG21</p>  <p>SEG22</p>
<p><b>18</b> Press the  button to move to the next page.</p>	
<p><b>19</b> Set the SEG23 and SEG24 values:</p> <p><b>a</b> Set the SEG23 value by pressing the  button repeatedly until the value you want to set appears on the remote control display.</p> <p><b>b</b> Set the SEG24 value by pressing the  button repeatedly until the value you want to set appears on the remote control display.</p> <p>When you press the  or  button, values appear in the following order:   →  → ... →  → </p>	 <p>SEG23</p>  <p>SEG24</p>

- 3 Check whether the option values you have set are correct by pressing the **M000** button repeatedly.



EX) AC018DNADCG

020010-100011-200000-300000

- 4 Save the option values into the indoor unit:  
Point the remote control to the remote control sensor on the indoor unit and then press the **(⏻)** button on the remote control twice.  
Make sure that this command is received by the indoor unit. When it is successfully received, you can hear a short sound from the indoor unit. If the command is not received, press the **(⏻)** button again.
- 5 Check whether the air conditioner operates following the option values you have set:
- Reset the indoor or outdoor unit.
    - Indoor Unit : Press **(⏻)** button + **(⏻)** button for 5 seconds
    - Outdoor Unit : Press the K3 button

- Reset remote control: **(⏻)** button Down + **(⏻)** button Down + **(M000)** Press for 10 seconds  
You can see the "SW Initialization" message.

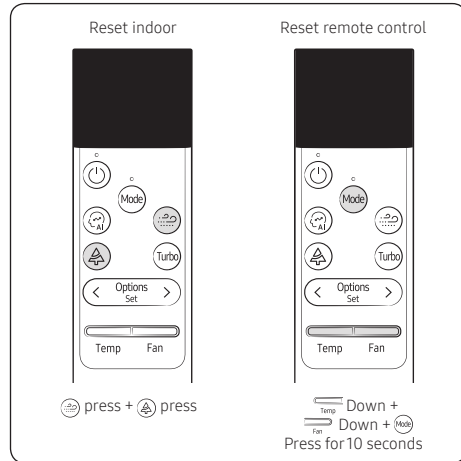

# Indoor Unit Installation

## Setting the indoor unit addresses

Option No. for an indoor unit address: 0AXXXX-1XXXX-2XXXX-3XXXX

Before installing an indoor unit, be sure to set an address for the indoor unit by taking the following steps:

- 1 Make sure that the power is supplied to the indoor unit. If the indoor unit is not plugged in, it must include a power supply.
- 2 Set an address for each indoor unit using the remote control, according to your air conditioning system plan, by referring to the following table and by following the steps in Common steps for setting the addresses and options on page 24.
  - The indoor unit addresses (main and RMC addresses) are set to 0A0000-100000-200000-300000 by default.
  - If indoor units and outdoor units match 1:1, you don't need to set the main address because it is automatically set by the outdoor unit.
  - If you are using on or off controller, set RMC address.

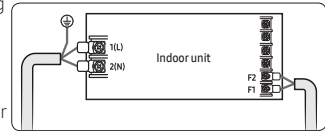

Option	SEG1		SEG2		SEG3		SEG4	SEG5		SEG6			
Function	Page		Mode		Setting main address		Reserved	Indoor unit number		Indoor unit number			
Indication and details	Indication	Details	Indication	Details	Indication	Details		Indication	Details	Indication	Details		
	0		A		0	No main address		0 to 1	Tens digit	0 to 9	Units digit		
					1	Main address setting mode							
Option	SEG7		SEG8		SEG9		SEG10	SEG11		SEG12			
Function	Page		Reserved		Setting RMC address		Reserved	Group channel (x16)		Group address			
Indication and details	Indication	Details			Indication	Details		Indication	Details	Indication	Details	Indication	Details
	1							0	No RMC address	RMC1	0 to 2	RMC2	0 to F
								1	RMC address setting mode				

### CAUTION

- The main address must be set to a value in the range 0 to 15. If you set other values, communication error will occur.
- If any of SEG5 and SEG6 is set to a value in the range A to F, the main address of the indoor unit does not change.
- If SEG3 is set to 0, the indoor unit maintains the existing main address even if SEG6 is set to a new value.
- If SEG9 is set 0, the indoor unit maintains the existing RMC address even if SEG11 and SEG12 are set to new values.



## Setting the installation options in a batch

Installation Option No. installation options : 02XXXX-1XXXXX-2XXXXX-3XXXXX

- 1 Make sure that the power is supplied to the indoor unit. If the indoor unit is not plugged in, it must include a power supply.
- 2 The panel (display) should be connected to an indoor unit to receive option.
- 3 Set the installation option according to the installation condition of an air conditioner.
  - The installation options of indoor units are set to like a below table by default.

Model	AC018DNADCG	AC024DNADCG
02 series installation option	020010-100011-200000-300000	020010-100041-200000-300000
05 series installation option	050030-100700-200000-300000	050030-100700-200000-300000

- Individual control of a remote controller(SEG20) is the function that controls an indoor unit individually when there is more than one indoor unit.
  - No need to assign SEG3, 6, 9, 10, 16, 22, 23, 24 which are non applicable. Even though those segments are set, they will be ignored.
  - If you set the applicable segments with numbers other than the indicated, the initial setting will be maintained.
- 4 Set the indoor unit option by wireless remote controller.







Option	SEG13		SEG14			SEG15		SEG16	SEG17		SEG18		
Function	Page		Use of external control			Setting the output of external control		Reserved	Buzzer control		Maximum filter usage time <sup>3)</sup>		
Indication and details	2	Indication	Details	Indication	Details	Indication	Details		Indication	Details	Indication	Details	
				0	Disuse	Sub, Existing control	0		Thermo on	Reserved	0	Use of buzzer	2
				1	On/Off								
				2	Off								
				3	Window On/Off		1	Operation on					
				4	Disuse	Main, Existing control	2	External heater use(Fan On when the heater is running) Emergency heater disuse					
				5	On/Off		3	External heater use(Fan OFF when the heater is running) Emergency heater disuse					
				6	Off		4	External heater use(Fan On when the heater is running, Fan off only in case of Defrost) Emergency heater disuse					
				7	Window On/Off	Sub, Reverse control		External heater use (Fan On when the heater is running) Emergency heater use	1		Disuse of buzzer	6	2000 hours
				8	Disuse								
				9	On/Off		A	Off					
				A	Window On/Off		Main, Reverse control	6					
				B	Window On/Off	7		External heater use(Fan On when the heater is running, Fan off only in case of Defrost) Emergency heater use					
				C	Disuse								
				D	On/Off								
		E	Off										
		F	Window On/Off										
Option	SEG19		SEG20		SEG21		SEG22		SEG23		SEG24		
Function	Page		Individual control with remote control <sup>4)</sup>		Heating setting compensation <sup>5)</sup>		Reserved	Reserved	Reserved	Reserved	Reserved		
Indication and details	3	Indication	Details	Indication	Details								
				0,1	Indoor1	0						Default	
				2	Indoor2	1						3.6°F (2°C)	
				3	Indoor3	2						9°F (5°C)	
				4	Indoor4								

- <sup>1)</sup> SEG4: By SEG4 setting, Minimizing fan operation when thermostat is off.
  - Fan operates for 20 seconds at an interval of 5 minutes in heat mode.
  - Fan stops or operates Ultra low in Cooling when thermostat is off.
- <sup>2)</sup> SEG8Drain pump: The Drain pump option is automatically set to [Used with 3minute delay], even if you set it to [Disuse]. Emergency Stop: If you set Emergency Stop to [Use], it is not possible to use the ETO or On/Off Control feature throughExternal Control (SEG14).
- <sup>3)</sup> SEG18: If you set the Maximum filter usage time option to a value other than 2 and 6, it is automatically set to 2 (1000 hours).
- <sup>4)</sup> SEG20: If you set the Individual control with remote control option to a value other than 0 to 4, it is automatically set to 0 (Indoor 1)



# Indoor Unit Installation

- If you input a number other than 0~4 on the individual control of the indoor unit(SEG20), the indoor is set as "Indoor1".  
Example) If you want to set as "Exterior temperature sensor : USE, External control : USE

SEG1	SEG2	SEG3	SEG4	SEG5	SEG6
0	2	-	1	0	-
SEG7	SEG8	SEG9	SEG10	SEG11	SEG12
1	0	-	-	-	0
SEG13	SEG14	SEG15	SEG16	SEG17	SEG18
2	1	0	-	0	0
SEG19	SEG20	SEG21	SEG22	SEG23	SEG24
3	0	-	-	-	-

Assign option codes except SEG 1, 7, 13, 19 which are page options.

## Changing the addresses and options individually

You can change each digit of set option.

Option	SEG1		SEG2		SEG3		SEG4		SEG5		SEG6	
Explanation	PAGE		MODE		The option mode you want to change		The tens' digit of an option SEG you will change		The unit digit of an option SEG you will change		The changed value	
Indication and Details	Indication	Details	Indication	Details	Indication	Details	Indication	Details	Indication	Details	Indication	Details
	0		D		Option mode	0~F	Tens' digit of SEG	0~9	Unit digit of SEG	0~9	The changed value	0~F

### NOTE

- When changing a digit of an indoor unit address setting option, set the SEG3 as 'A'.
- When changing a digit of indoor unit installation option, set the SEG3 as '2'.

Example) When setting the 'buzzer control' into disuse status.

Option	SEG1	SEG2	SEG3	SEG4	SEG5	SEG6
Explanation	PAGE	MODE	The option mode you want to change	The tens' digit of an option SEG you will change	The unit digit of an option SEG you will change	The changed value
Indication	0	D	2	1	7	1

05 series installation option (Detailed)

Option No.: 05XXXX-1XXXX-2XXXX-3XXXX

SEG1		SEG2		SEG3	SEG4	SEG5	SEG6		
Page		Mode		Reserved	Reserved	Reserved	Auxiliary heater offset temp. and time delay		
Indication	Details	Indication	Details				Indication	Details	
								Set temperature for auxiliary heat on	Time delay for auxiliary heat on
0		5	Installation Option 2	Reserved	Reserved	Reserved	0	No temperature offset	No delay
							1	No temperature offset	10 minutes
							2	No temperature offset	20 minutes
							3	2.7°F(1.5°C)	No delay
							4	2.7°F(1.5°C)	10 minutes
							5	2.7°F(1.5°C)	20 minutes
							6	5.4°F(3°C)	No delay
							7	5.4°F(3°C)	10 minutes
							8	5.4°F(3°C)	20 minutes
							9	8.1°F(4.5°C)	No delay
							A	8.1°F(4.5°C)	10 minutes
							B	8.1°F(4.5°C)	20 minutes
							C	10.8°F(6°C)	No delay
							D	10.8°F(6°C)	10 minutes
							E	10.8°F(6°C)	20 minutes

# Indoor Unit Installation

SEG7		SEG8		SEG9		SEG10		SEG11	SEG12		
Page		Heater lock out		Heat pump lock out		Bit 0 : Allow Fan control in auto mode Bit 1 : Onboarding Type(AP / BLE)		0	Reserved		
Indication	Details	Indication	Details	Indication	Details	Details					
1	0	Disuse		0	Disuse		0			Not allow	AP Onboarding
	1	65 °F(18.3 °C)	1	45 °F(7.2 °C)	1	allow				AP Onboarding	
	2	60 °F(15.6 °C)	2	40 °F(4.4 °C)	2	Not allow				BLE Onboarding	
	3	55 °F(12.8 °C)	3	35 °F(1.7 °C)	3	allow				BLE Onboarding	
	4	50 °F(10.0 °C)	4	30 °F(-1.1 °C)	4	Not allow				AP Onboarding	
	5	45 °F(7.2 °C)	5	25 °F(-3.9 °C)	5	allow				AP Onboarding	
	6	40 °F(4.4 °C)	6	20 °F(-6.7 °C)	6	Not allow				BLE Onboarding	
	7	35 °F(1.7 °C)	7	15 °F(-9.4 °C)	7	allow				BLE Onboarding	
	8	30 °F(-1.1 °C)	8	10 °F(-12.2 °C)	8	Not allow				AP Onboarding	
	9	25 °F(-3.9 °C)	9	5 °F(-15 °C)	9	allow				AP Onboarding	
	A	20 °F(-6.7 °C)	A	0 °F(-17.8 °C)	A	Not allow				BLE Onboarding	
	B	15 °F(-9.4 °C)	B	-5 °F(-20.6 °C)	B	allow				BLE Onboarding	
	C	10 °F(-12.2 °C)	C	-10 °F(-23 °C)	C	Not allow		BLE Onboarding			
	D	5 °F(-15 °C)	D	-15 °F(-26 °C)	D	allow		BLE Onboarding			
E	0 °F(-17.8 °C)	E	-20 °F(-29 °C)	E	Not allow		BLE Onboarding				
SEG13		SEG14		SEG15		SEG16		SEG17		SEG18	
Page		Reserved	Reserved	Reserved	Reserved	Reserved	Reserved	Reserved	Reserved	Reserved	Reserved
Indication	Details										
2											
SEG19		SEG20		SEG21		SEG22		SEG23		SEG24	
Page		Reserved	Reserved	Reserved	Reserved	Reserved	Reserved	Reserved	Reserved	Reserved	Reserved
Indication	Details										
3											

## Changing the addresses and options individually

When you want to change the value of a specific option, refer to the following table and follow the steps in **Common steps for setting the addresses and options** on page 25.

Option	SEG1		SEG2		SEG3		SEG4		SEG5		SEG6	
Function	Page		Mode		Option mode to change		Tens position of the option number		Units position of the option number		New value	
Indication and details	Indication	Details	Indication	Details	Indication	Details	Indication	Details	Indication	Details	Indication	Details
		0		D		Option type	0 to F	Tens position value	0 to 9	Units position value	0 to 9	New value

Example: Changing the Buzzer control (SEG17) option of the installation options to 1 disuse.

Option	SEG1	SEG2	SEG3	SEG4	SEG5	SEG6
Function	Page	Mode	Option mode to change	Tens position of the option number	Units position of the option number	New value
Indication	0	D	2	1	7	1

# Troubleshooting

## Detection of errors

- If an error occurs during the operation, an LED flickers and the operation is stopped except the LED.
- If you re-operate the air conditioner, it operates normally at first, then detect an error again.

LED Display on the receiver & display unit

## LED Display

- If you turn off the air conditioner when the LED is flickering, the LED is also turned off.
- If you re-operate the air conditioner, it operates normally at first, then detect an error again.
- When E108 error occurs, change the address and reset the system.Ex.) When address of the indoor unit #1 and #2 are set as 5, address of the indoor unit #1 will become 5 and indoor unit #2 will display E108, A002.

Abnormal condition	Error code
Error on indoor temperature sensor (Short or Open)	E121
1. Error on Eva-in sensor (Short or Open)	E122
2. Error on Eva-out sensor (Short or Open)	E123
3. Discharge sensor error (Short or Open)	E126
Indoor fan error	E154
1. Error on outdoor temperature sensor (Short or Open)	E221
2. Error on cond sensor	E237
3. Error on discharge sensor	E251
Other outdoor unit sensor error that is not on the above list	E101
1. When there is no communication between the indoor-outdoor units for 2 minutes	E102
2. Communication error received from the outdoor unit	E202
3. 3 minute tracking error on outdoor unit	E201
4. Communication error after tracking due to unmatching number of installed units	E108
5. Error due to repeated communication address	E109
6. Communication address not confirmed	E109
Other outdoor unit communication error that is not on the above list	
Self diagnosis error display	
1. Error due to opened EEV (2nd detection)	E151
2. Error due to closed EEV (2nd detection)	E152
3. Eva in sensor is detached	E128
4. Eva out sensor is detached	E129
5. Thermal fuse error (Open)	E198

# Troubleshooting

Abnormal condition	Error code
1. COND mid sensor is detached	E241
2. Refrigerant leakage (2nd detection)	E554
3. Abnormally high temperature on Cond (2nd detection)	E450
4. Low pressure s/w (2nd detection)	E451
5. Abnormally high temperature on discharged air on outdoor unit (2nd detection)	E416
6. Indoor operation stop due to unconfirmed error on outdoor unit	E559
7. Error due to reverse phase detection	E425
8. Comp stop due to freeze detection (6th detection)	E403
9. High pressure sensor is detached	E301
10. Low pressure sensor is detached	E306
11. Outdoor unit copression ration error	E428
12. Outdoor sump down_1 prevetion control	E413
13. Compressor down due to low pressure sensor prevention control_1	E410
14. Simultaneous opening of cooling/heating MCU SOL valve (1st detection)	E180
15. Simultaneous opening of cooling/heating MCU SOL valve (2nd detection)	E181
Other outdoor unit self-diagnosis error that is not on the above list	
EEPROM error	E162
1. Floating s/w (2nd detection)	E665
2. Emergency alarm system on (Emergency Stop)	

**SAMSUNG**