



# FRIEDRICH

## RoomAir Conditioners

### Chill Premiere Series Models



**Fixed chassis, cool only**  
CCF05A10A, CCF06A10A, CCF08A10A, CCF10A10A  
CCF12A10A

**Slide out chassis, cool only**  
CCW06B10A, CCW08B10A, CCW10B10A, CCW12B10A  
CCW15B10A, CCW18B30A, CCW24B30A

**Slide out chassis, heat & cool**  
CEW08B11A, CEW12B33A, CEW18B33A, CEW24B33A

### Unifit Series Models



**Cool Only**  
UCT08A10A, UCT10A10A, UCT10A30A, UCT12A10A,  
UCT12A30A, UCT14A30A

**Cool with Electric Heat**  
UET08A11A, UET10A33A, UET12A33A, UET14A33A

Table of Contents	
INTRODUCTION	3
IMPORTANT SAFETY INFORMATION	3
PERSONAL INJURY OR DEATH HAZARDS	4
SPECIFICATIONS	7
Electrical Data	9
Product Dimensions	11
OPERATION	12
Remote Control	12
Control Panel	13
Sequence of Operation	15
R-410A SEALED SYSTEM REPAIR	22
Refrigerant Charging	23
Undercharged Refrigerant Systems	24
Overcharged Refrigerant Systems	25
Restricted Refrigerant System	26
Sealed System Method of Charging/ Repairs	27
COMPONENT TESTING	28
Hermetic Components Check	28
Reversing valve description and operation	29
Testing The Reversing Valve Solenoid Coil	30
Checking The Reversing Valve	31
Replace The Reversing Valve	32
Touch Test Chart : To Service Reversing Valves	33
Compressor Checks	34
Compressor Replacement	36
Compressor Replacement -Special Procedure in Case of Compressor Burnout	37
Fan Motor	38
Capacitors	38
TROUBLESHOOTING	39
Product Does Not Operate At All	40
Indoor Fan Does Not Operate At All	41
Compressor Or Outdoor Fan Does Not Operat At All	42
Display E1 or E2	43
WIRING DIAGRAMS	44
Chill Premier CCF	44
Chill Premier CCW	46
Chill Premier CEW	48
Unifit	51
PARTS CATALOG	53
Chill Premier Models: CCW06B10A CCW08B10A CCW10B10A CCW12B10A	53
Chill Premier Models: CCW06B10A CCW08B10A CCW10B10A CCW12B10A	54
Chill Premier Models: CCW15B10A CCW18B30A	56
Chill Premier Models: CCW24B30A	59
Chill Premier Models: CCW24B30A	60
Chill Premier Models: CEW08B11A, CEW12B33A	63
Chill Premier Models: CEW08B11A, CEW12B33A	64
Chill Premier Models: CEW08B11A, CEW12B33A	65
Chill Premier Models: CEW18B33A	66
Chill Premier Models: CEW24B33A	70
Chill Premier Models: CCF05A10A CCF06A10A CCF08A10A	75
Chill Premier Models: CCF10A10A CCF12A10A	78
Unifit Models: UCT08A10A UCT10A10A UCT12A10A UCT10A30A	81
Unifit Models: UCT12A30, UCT14A30A	84
Unifit Models: UET08A11A UET10A33A UET12A33A	86
Unifit Models: UET14A33A	89
Available Accessories	91
FRIEDRICH AUTHORIZED PARTS DEPOTS	94

# INTRODUCTION

## IMPORTANT SAFETY INFORMATION

The information in this manual is intended for use by a qualified technician who is familiar with the safety procedures required for installation and repair, and who is equipped with the proper tools and test instruments required to service this product.

Installation or repairs made by unqualified persons can result in subjecting the unqualified person making such repairs as well as the persons being served by the equipment to hazards resulting in injury or electrical shock which can be serious or even fatal.

Safety warnings have been placed throughout this manual to alert you to potential hazards that may be encountered. If you install or perform service on equipment, it is your responsibility to read and obey these warnings to guard against any bodily injury or property damage which may result to you or others.



**Your safety and the safety of others is very important.**



We have provided many important safety messages in this manual and on your appliance. Always read and obey all safety messages.

This is a safety Alert symbol.  
This symbol alerts you to potential hazards that can kill or hurt you and others.



All safety messages will follow the safety alert symbol with the word "WARNING" or "CAUTION". These words mean:

 <b>WARNING</b>	Indicates a hazard which, if not avoided, can result in severe personal injury or death and damage to product or other property.
 <b>CAUTION</b>	Indicates a hazard which, if not avoided, can result in personal injury and damage to product or other property.
<b>NOTICE</b>	All safety messages will tell you what the potential hazard is, tell you how to reduce the chance of injury, and tell you what will happen if the instructions are not followed. Indicates property damage can occur if instructions are not followed.

 <b>WARNING</b>	
	<p><b>Refrigeration system under high pressure</b></p> <p>Do not puncture, heat, expose to flame or incinerate.</p> <p>Only certified refrigeration technicians should service this equipment.</p> <p>R410A systems operate at higher pressures than R22 equipment. Appropriate safe service and handling practices must be used.</p> <p>Only use gauge sets designed for use with R410A.</p> <p>Do not use standard R22 gauge sets.</p>

---

# INTRODUCTION

## PERSONAL INJURY OR DEATH HAZARDS

SAFETY FIRST	⚠ WARNING	⚠ AVERTISSEMENT	⚠ ADVERTENCIA
	Do not remove, disable or bypass this unit's safety devices. Doing so may cause fire, injuries, or death.	Ne pas supprimer, désactiver ou contourner cette l'unité des dispositifs de sécurité, faire vous risqueriez de provoquer le feu, les blessures ou la mort.	No eliminar, desactivar o pasar por alto los dispositivos de seguridad de la unidad. Si lo hace podría producirse fuego, lesiones o muerte.

### ELECTRICAL HAZARDS:

- Unplug and/or disconnect all electrical power to the unit before performing inspections, maintenance, or service.
- Make sure to follow proper lockout/tag out procedures.
- Always work in the company of a qualified assistant if possible.
- Capacitors, even when disconnected from the electrical power source, retain an electrical charge potential capable of causing electric shock or electrocution.
- Handle, discharge, and test capacitors according to safe, established, standards, and approved procedures.
- Extreme care, proper judgment, and safety procedures must be exercised if it becomes necessary to test or troubleshoot equipment with the power on to the unit.
- Do not spray water on the air conditioning unit while the power is on.
- Electrical component malfunction caused by water could result in electric shock or other electrically unsafe conditions when the power is restored and the unit is turned on, even after the exterior is dry.
- Use air conditioner on a single dedicated circuit within the specified amperage rating.
- Use on a properly grounded outlet only.
- Do not cut or modify the power supply cord or remove the ground prong of the plug.
- Never operate the unit on an extension cord.
- Follow all safety precautions and use proper and adequate protective safety aids such as: gloves, goggles, clothing, properly insulated tools, and testing equipment etc.
- Failure to follow proper safety procedures and/or these warnings can result in serious injury or death.

---

# INTRODUCTION

## PERSONAL INJURY OR DEATH HAZARDS

- **REFRIGERATION SYSTEM REPAIR HAZARDS:**

- Use approved standard refrigerant recovering procedures and equipment to relieve high pressure before opening system for repair.
- Do not allow liquid refrigerant to contact skin. Direct contact with liquid refrigerant can result in minor to moderate injury.
- Be extremely careful when using an oxy-acetylene torch. Direct contact with the torch's flame or hot surfaces can cause serious burns.
- Make certain to protect personal and surrounding property with fire proof materials and have a fire extinguisher at hand while using a torch.
- Provide adequate ventilation to vent off toxic fumes, and work with a qualified assistant whenever possible.
- Always use a pressure regulator when using dry nitrogen to test the sealed refrigeration system for leaks, flushing etc.

- **MECHANICAL HAZARDS:**

- Extreme care, proper judgment and all safety procedures must be followed when testing, troubleshooting, handling, or working around unit with moving and/or rotating parts.
- Be careful when, handling and working around exposed edges and corners of the sleeve, chassis, and other unit components especially the sharp fins of the indoor and outdoor coils.
- Use proper and adequate protective aids such as: gloves, clothing, safety glasses etc.
- Failure to follow proper safety procedures and/or these warnings can result in serious injury or death.

- **PROPERTY DAMAGE HAZARDS**

- **FIRE DAMAGE HAZARDS:**

- Read the Installation/Operation Manual for the air conditioning unit prior to operating.
- Use air conditioner on a single dedicated circuit within the specified amperage rating.
- Connect to a properly grounded outlet only.
- Do not remove ground prong of plug.
- Do not cut or modify the power supply cord.
- Do not use extension cords with the unit.
- Be extremely careful when using acetylene torch and protect surrounding property.
- Failure to follow these instructions can result in fire and minor to serious property damage.

- **WATER DAMAGE HAZARDS:**

- Improper installation, maintenance or servicing of the air conditioner unit can result in water damage to personal items or property.
- Insure that the unit has a sufficient pitch to the outside to allow water to drain from the unit.
- Do not drill holes in the bottom of the drain pan or the underside of the unit.
- Failure to follow these instructions can result in damage to the unit and/or minor to serious property damage.

---

# INTRODUCTION

This service manual is designed to be used in conjunction with the installation and operation manuals provided with each air conditioning system.

This service manual was written to assist the professional service technician to quickly and accurately diagnose and repair malfunctions.

Installation procedures are not given in this manual. They are given in the Installation/Operation manual which can be acquired on the Friedrich website.

**IMPORTANT:** It will be necessary for you to accurately identify the unit you are servicing, so you can be certain of a proper diagnosis and repair.

# SPECIFICATIONS

Model	Cooling Btu	Heating Btu	Volts Rated	Cooling Amps	Cooling Watts	Heating Amps	Heating Watts	EER	CEER	Moisture Removal- Pints/HR	Refrigerant	Refrigerant Charge	CFM	Sleeve	Weight Net./ Ship lbs.
<b>FIXED CHASSIS, COOL ONLY (WINDOW INSTALLATION ONLY)</b>															
CCF05A10A	5200	—	115	4.3	459	—	—	12.1	12.1	1.0	R410A	12.35	141		44/51
CCF06A10A	6000	—	115	4.3	492	—	—	12.1	12.1	0.9	R410A	13.76	141		44/51
CCF08A10A	8000	—	115	5.8	661	—	—	12.1	12.0	1.0	R410A	14.46	206		51/57
CCF10A10A	10000	—	115	7.3	826	—	—	12.1	12.0	1.2	R410A	19.4	282		64/73
CCF12A10A	12000	—	115	8.6	992	—	—	12.1	12.0	1.5	R410A	22.93	270		73/82
<b>CHILL PREMIER SLIDE OUT CHASSIS, COOL ONLY</b>															
CCW06B10A	6000	—	115	4.3	492	—	—	12.2	12.1	0.9	R410A	13.76	200		44/51
CCW08B10A	8000	—	115	5.8	661	—	—	12.1	12.0	1.0	R410A	14.46	250		44/61
CCW10B10A	10000	—	115	7.3	826	—	—	12.1	12.0	1.2	R410A	19.4	300		51/68
CCW12B10A	12000	—	115	8.6	992	—	—	12.1	12.0	1.5	R410A	22.93	330		64/86
CCW15B10A	15000	—	115	11.0	1270	—	—	11.9	11.8	2.0	R410A	28.22	400		73/93
CCW18B30A	18000	—	230	7.1	1525	—	—	11.9	11.8	2.7	R410A	29.98	520		106/136
CCW24B30A	24000	—	230	10.2	2308	—	—	10.4	10.3	2.7	R410A	37.03	590		117/144
<b>CHILL PREMIER SLIDE OUT CHASSIS, HEAT &amp; COOL</b>															
CEW08B11A	8000	4200	115	6.3	670	—	—	11.0	10.9	2.1	R410A	14.46	250		44/61
CEW12B33A	12000	10600	230	4.8	1060	—	—	11.0	10.9	3.3	R410A	29.98	265		64/86
CEW18B33A	18000	10600	230	7.2	1600	—	—	10.8	10.7	5.5	R410A	29.98	430		106/136
CEW24B33A	24000	10600	230	10.6	2340	—	—	9.5	9.4	6.5	R410A	37.03	560		117/144
<b>UNI-FIT® Cool Only</b>															
UCT08A10A	8000	—	115	6.9	755	—	—	10.7	10.6	0.8	R410A	14.46	265	64	64/78
UCT10A10A	10000	—	115	8.3	940	—	—	10.7	10.6	1.25	R410A	19.05	247	74	74/86
UCT10A30A	10000	—	230	4.5	940	—	—	10.7	10.6	1.25	R410A	19.75	265	74	74/86
UCT12A10A	12000	—	115	10.1	1130	—	—	10.6	10.5	1.7	R410A	22.22	276	75	75/88
UCT12A30A	12000	—	230	5.4	1130	—	—	10.6	10.5	1.7	R410A	22.22	265	75	75/88
UCT14A30A	14000	—	230	7.2	1490	—	—	9.4	9.3	2.15	R410A	22.22	265	76	76/89
<b>UNI-FIT® Cool with Electric Heat</b>															
UET08A11A	8000	4200	115	7.2	810	12.5	1320	9.7	9.6	0.75	R410A	13.76	265	66	66/79
UET10A33A	10000	10600	230	4.9	1030	15	3500	9.7	9.6	1.2	R410A	17.99	276	75	75/87
UET12A33A	12000	10600	230	5.9	1230	15	3500	9.7	9.6	1.65	R410A	20.1	276	76	76/89
UET14A33A	14000	10600	230	7.2	1490	15	3500	9.4	9.3	2.15	R410A	22.22	265	77	77/90

**Figure 201 (Refrigeration Systems Performance Data)**

# SPECIFICATIONS

Model	Height Inches	Width Inches	Depth Inches	Minimum Extension Into Room Inches	Minimum Extension Outside Inches	Window Width Inches	
						Minimum*	Maximum
CCF05A10A, CCF06A10A,	13 <sup>5</sup> / <sub>8</sub>	18 <sup>5</sup> / <sub>8</sub>	15 <sup>5</sup> / <sub>8</sub>	—	—	26	36
CCF08A10A	13 <sup>3</sup> / <sub>8</sub>	18 <sup>5</sup> / <sub>8</sub>	17 <sup>5</sup> / <sub>8</sub>	—	—	26	36
CCF10A10A, CCF12A10A	15 <sup>1</sup> / <sub>8</sub>	19 <sup>7</sup> / <sub>8</sub>	21 <sup>3</sup> / <sub>4</sub>	—	—	26	36
CCW06B10A, CCW08B10A, CEW08B11A, CCW10B10A, CCW12B10A, CEW12B33A,	14 <sup>5</sup> / <sub>8</sub>	19 <sup>3</sup> / <sub>4</sub>	23 <sup>3</sup> / <sub>4</sub>	—	—	26	36
CCW15B10A, CCW18B30A, CEW18B33A	18	23 <sup>7</sup> / <sub>8</sub>	25 <sup>3</sup> / <sub>8</sub>	—	—	26	36
CCW06B10B, CCW08B10B	13 <sup>3</sup> / <sub>8</sub>	18 <sup>5</sup> / <sub>8</sub>	17 <sup>5</sup> / <sub>8</sub>	—	—	26	36
CCW24B30A, CEW24B33A	18 <sup>5</sup> / <sub>8</sub>	27	26 <sup>5</sup> / <sub>8</sub>	—	—	26	36

Figure 202 (Chill Premier Installation)

Sleeve Dimensions	Friedrich USC Sleeve	Amana	Carrier (51S Series)	Fedders/ Emerson/ Friedrich WSE	Emerson/ Fedders	GE/ Hotpoint	Whirlpool	White-Westinghouse/ Frigidaire/ Carrier (52F Series)
Height	15 <sup>1</sup> / <sub>2</sub> "	15 <sup>5</sup> / <sub>8</sub> "	16 <sup>7</sup> / <sub>8</sub> "	16 <sup>3</sup> / <sub>4</sub> "	15 <sup>3</sup> / <sub>4</sub> "	15 <sup>5</sup> / <sub>8</sub> "	16 <sup>1</sup> / <sub>2</sub> "	15 <sup>1</sup> / <sub>4</sub> "
Width	25 <sup>7</sup> / <sub>8</sub> "	26"	25 <sup>3</sup> / <sub>4</sub> "	27"	26 <sup>3</sup> / <sub>4</sub> "	26"	25 <sup>7</sup> / <sub>8</sub> "	25 <sup>1</sup> / <sub>2</sub> "
Depth	16 <sup>3</sup> / <sub>4</sub> "	16 <sup>7</sup> / <sub>8</sub> "	18 <sup>5</sup> / <sub>8</sub> "	16 <sup>3</sup> / <sub>4</sub> " or 19 <sup>3</sup> / <sub>4</sub> "	15"	16 <sup>7</sup> / <sub>8</sub> "	17 <sup>1</sup> / <sub>8</sub> " or 23"	16", 17 <sup>1</sup> / <sub>2</sub> " or 22"

Figure 203 Unifit ( Sleeve Dimensions)

## Installation Clearances

Improper installation of the Air Conditioner can cause poor performance and premature wear of the unit. Ensure that the unit is installed with proper clearances as described below. Ensure no obstructions, or enclosures are within clearances limits to allow for proper airflow.

Clearances

Rear of Unit - Three (3) feet





# SPECIFICATIONS

## Electrical Data

<b>⚠ WARNING</b>	
	<p><b>ELECTRIC SHOCK HAZARD</b></p> <p>Turn off electric power before service or installation.</p> <p>All electrical connections and wiring <b>MUST</b> be installed by a qualified electrician and conform to the National Electrical Code and all local codes which have jurisdiction.</p> <p>Failure to do so can result in personal injury or death.</p>

<b>NOTICE</b>
<p><b>FIRE HAZARD</b></p> <p>Not following the above WARNING could result in fire or electrically unsafe conditions which could cause moderate or serious property damage.</p> <p>Read, understand and follow the above warning.</p>



Model	Circuit Rating Breaker or T-D Fuse	Plug Face (NEMA#)	Power Cord Length (ft.)	Wall Outlet Appearance
ALL CCF MODELS. CCW06B10A, CCW08B10A, CCW10B10A, CCW12B10A, CEW08B11A	<b>125V-15A</b>	<b>5-15P</b>	<b>6</b>	
<b>Chill® Premier</b> CCW15B10A			<b>5.5</b>	
<b>UNI-FIT®</b> UCT08A10A, UCT10A10A, UCT12A10A			<b>6</b>	
<b>Chill® Premier</b> CCW18B30A, CCW24B30A	<b>250V - 15A</b>	<b>6 - 15P</b>	<b>4.5</b>	
<b>UNI-FIT®</b> UET10A33A, UET12A33A, UET14A33A		<b>6-20P</b>	<b>6</b>	
<b>Chill® Premier</b> CCW18B30A, CCW24B30A	<b>250V-20A</b>	<b>6-20P</b>	<b>4</b>	
<b>Chill® Premier</b> CEW12B33A, CEW18B33A, CEW24B33A			<b>6</b>	
<b>UNI-FIT®</b> UET10A33A, UET12A33A, UET14A33A			<b>4.75</b>	

**Figure 204 (Circuit Breaker / Plug / Receptacle / Cord Rating)**

---

# SPECIFICATIONS

## Electrical Data

 <b>WARNING</b>	
	<p><b>Electrical Shock Hazard</b></p> <p>Make sure your electrical receptacle has the same configuration as your air conditioner's plug. If different, consult a Licensed Electrician.</p> <p>Do not use plug adapters.</p> <p>Do not use an extension cord.</p> <p>Do not remove ground prong. Always plug into a grounded 3 prong outlet.</p> <p>Failure to follow these instructions can result in death, fire, or electrical shock.</p>

**Wire Size** - Use ONLY wiring size recommended for single outlet branch circuit.

**Fuse/ Circuit Breaker** - Use ONLY the correct HACR type and size fuse/circuit breaker. Read electrical ratings on unit's rating plate. Proper circuit protection is the responsibility of the homeowner.

**Grounding** - Unit MUST be grounded from branch circuit through service cord to unit, or through separate ground wire provided on permanently connected units. Be sure that branch circuit or general purpose outlet is grounded.

**Receptacle** - The field supplied outlet must match plug on service cord and be within reach of service cord. Do NOT alter the service cord or plug. Do NOT use an extension cord. Refer to the table above for proper receptacle and fuse type.

**Make sure the wiring is adequate for your unit.**

If you have fuses, they should be of the time delay type. Before you install or relocate this unit, be sure that the amperage rating of the circuit breaker or time delay fuse does not exceed the amp rating listed in Table 206.

**DO NOT use an extension cord.**

The cord provided will carry the proper amount of electrical power to the unit; an extension cord may not.

**Make sure that the receptacle is compatible with the air conditioner cord plug provided.**

Proper grounding must be maintained at all times. Two prong receptacles must be replaced with a grounded receptacle by a certified electrician.

The grounded receptacle should meet all national and local codes and ordinances. You must use the three prong plug furnished with the air conditioner. Under no circumstances should you remove the ground prong from the plug.

# SPECIFICATIONS

## Product Dimensions

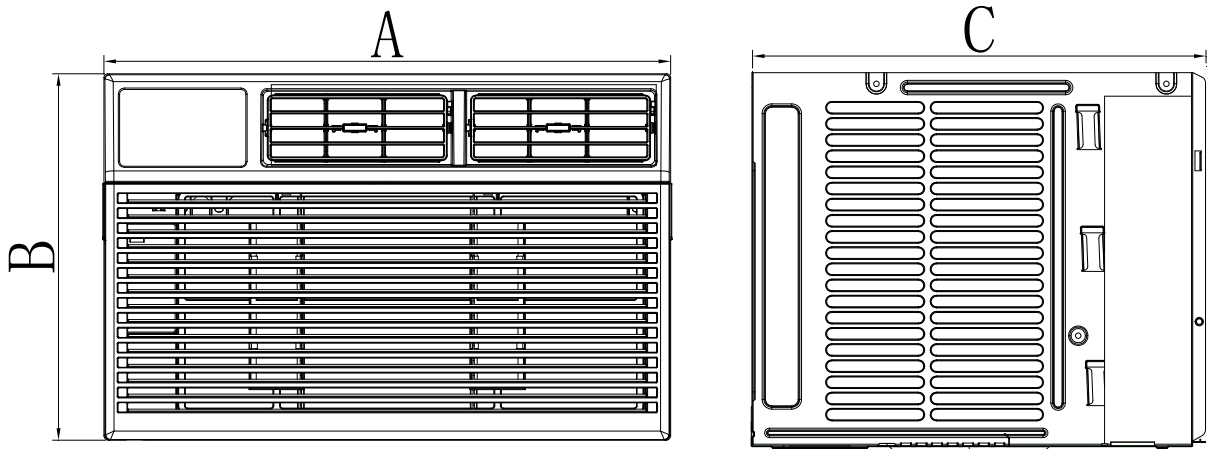

Model	A "(inches)	B "(inches)	C "(inches)
Chill® Premier			
CCF05A10A, CCF06A10A	13 3/8	18 5/8	15 5/8
CCF08A10A	13 3/8	18 5/8	17 5/8
CCF10A10A, CCF12A10A	15 1/8	19 7/8	21 3/4
CCW06B10A, CCW08B10A, CEW08B11A, CCW10B10A, CCW12B10A, CEW12B33A,	14 5/8	19 3/4	23 3/4
CCW06B10B, CCW08B10B	13 3/8	18 5/8	17 5/8
CCW15B10A, CCW18B30A, CEW18B33A	18	23 7/8	25 3/8
CCW24B30A, CEW24B33A	18 5/8	27	26 5/8
UNI-FIT®			
All Models	24 7/32	14 17/32	20 9/32

Figure 205

# OPERATION

## Remote Control

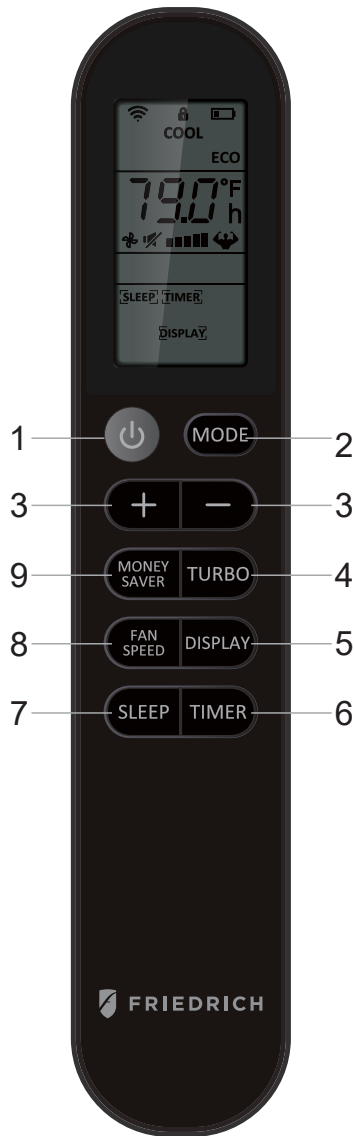

**1. Power:** Turn the air conditioner on and off. This button will clear the TIMER setting.

**2. MODE:** Press the button to select the mode of operation, AUTO, COOL, DRY, FAN ONLY, HEAT.

**Note:** The HEAT mode is only for some heating models. If you do not need it, press the MODE button for more than 5 seconds to delete the HEAT function, and the COOL mode will be selected automatically. Press the MODE again for more than 5 seconds to add the HEAT function, and the HEAT mode will be selected automatically.

**3. + And - :** Use these buttons to increase or decrease the setting Temperature or Timer. Setting temperature range: 61 ~88°F or 16 ~31°C .

**Note:** After setting temperature with remote using th + and - buttons, both the remote display and the unit display will automatically turn off after a short time. This does not affect the unit operation.

**4. TURBO:** When the remote is ON, press the button to activate the TURBO function, under AUTO/COOL/FAN ONLY mode. Press again to cancel the TURBO function, and the fan speed will change to pre-setting before.

**Note:** °F and °C change: After inserting the batteries, in the off state within 3 minutes, press the TURBO button for more than 5 seconds to switch the Fahrenheit (°F) or Celsius (°C) degree display.

**5. DISPLAY:** When the unit is ON, press the button, to switch off/on all lights or LED display. And this function will be canceled when changing mode.

**6. TIMER:** Use the button to set the TIMER, or cancel the TIMER.

**TIMER OFF:** When the unit is ON, the timed OFF is programmed by pressing TIMER button, the remote will display 6 hours pre-setting at first.

Set the rest time by pressing the button or until the needed rest time display, then press TIMER button again to confirm.

**TIMER ON:** When the unit is OFF, the timed ON is programmed by pressing TIMER button, the remote will display 6 hours pre-setting at first. Set the rest time by pressing the button or until the needed rest time display, then press TIMER button again to confirm. Later, the remote screen will keep display [TIMER] icon.

**Note:** When TIMER ON, it cannot select Sleep mode, but can pre-set Mode, temperature, fan speed, ECO.

**7. SLEEP:** Press the SLEEP button, all of the display lights will turn off after a while, but the Sleep light is always on. In SLEEP mode, the air conditioner will automatically adjust the temperature and fan speed to make the room more comfortable during the night. The set temperature will automatically raise every 30-60 minutes and at most change six times until the set temperature is 81 or 82°F. This function can be selected when COOL or HEAT mode.

**8. FAN SPEED:** Press the FAN SPEED button to choose the fan speed options. You can choose Hi, Med, Lo or Auto speed in COOL or HEAT mode and choose Hi, Med, Lo in FAN mode. When DRY mode, it is only Low fan speed.

**9. MONEY SAVER:** When the unit is in COOL mode, press the button to MONEY SAVER function. In MONEY SAVER mode, the unit will turn off once the room is cooled to the user set temperature. The unit will turn back on when the room temperature rises above the user set temperature. Before the compressor starts, the fan motor will run for 20 sec., then it will stop for 10 min., and will repeat to provide a much more comfortable feeling and save energy.

**Battery size:** AAA

**Note:** Do not mix old and new batteries or different types of AAA batteries.

**Figure 301 (Remote Control Operation)**

# OPERATION

## Control Panel

### USING YOUR AIR CONDITIONER Electronic Control Panel & Remote Control

NOTE: This display always shows the room temperature in Fan Mode except when setting the Timer.

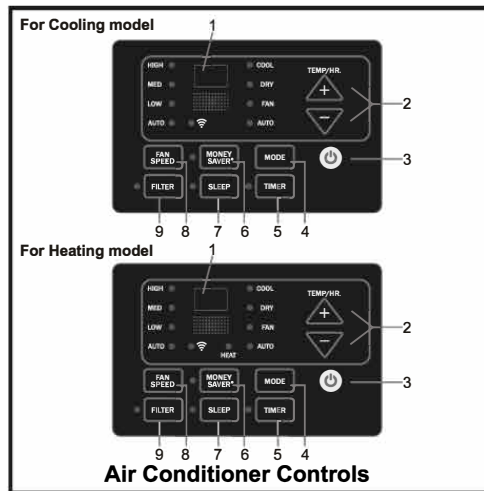

Air Conditioner Controls

#### Normal Operating Sounds

- You may hear a pinging noise caused by water hitting the condenser on rainy days, or when the humidity is high. This design feature helps remove moisture and improve efficiency.
  - You may hear the thermostat click when the compressor cycles on and off.
  - Water will collect in the base pan during rain or days of high humidity. The water may overflow and drip from the outside part of the unit.
  - The fan may run even when the compressor is not on.
- Digital Display:** Without timer setting, the set temperature will be displayed. Time will be displayed under the timer setting.
  - + and - Button:** Use these buttons on the control panel and remote to increase or decrease the Set Temperature or Timer. Temperature range: 61°F~88°F or 16°C~31°C.
  - ⏻ Button:** Turn the air conditioner on and off.
  - Mode Button:** Press the mode button to cycle through the various modes: Cool, Dry, Fan and Auto, or Heat.

**Cool Mode:** The cooling function allows the air conditioner to cool the room and at the same time reduces air humidity. Press the MODE button to activate the cooling function. To optimize the function of the air conditioner, adjust the temperature and the speed by pressing the button indicated.

**Dry Mode:** This function reduces the humidity of the air to make the room more comfortable. Press MODE button to set the DRY mode. An automatic function of alternating cooling cycles and air fan is activated.

**Fan Mode:** The conditioner works in only ventilation. Press MODE button to set the FAN mode. With pressing the FAN SPEED button the speed changes in the following sequence: Hi, Med and Lo in FAN mode.

**Auto Mode:** In AUTO mode the unit automatically chooses the fan speed and the mode of operation (COOL, HEAT, DRY or FAN). In this mode the temperature is set automatically according to the room temperature (tested by the temperature sensor which is incorporated in the indoor unit.).

**Heat Mode:** The heating function allows the air conditioner to heat the room. Press the MODE button to activate the heating function. To optimize the function of the air conditioner, adjust the temperature and the speed by pressing the button indicated.

- Timer Button:** Use these buttons on the control panel and remote to set the Timer.

**Timer Off:** The timed stop is programmed by pressing TIMER button. Set the rest time by pressing the button “+” or “-” until the rest time displayed is to your liking then press the TIMER button again.

**Timer On:** When the unit is off, press TIMER button at the first time, set the temperature with pressing the button “+” or “-”. Press TIMER button at the second time, set the rest time with pressing the button “+” or “-”. Press TIMER button at the third time, confirm the setting, then the rest time to next automatic switching-on could be read on the display of the machine. **Note:** It can be set to automatically turn off or on in 0.5-24 hours. Each press of the “+” “-” buttons will increase or decrease the timer. The Timer can be set in 0.5 hours increment below 10 hours and 1 hour increment for 10 hours or above. The SET light will turn on while setting. To cancel the set function, press the TIMER button again.

---

# OPERATION

## Control Panel

6. **Money Saver Button:** When the unit is in Money Saver mode, the light will turn on. In Money Saver mode, the unit will turn off once the room is cooled to the user-set temperature.

The unit will turn back on when the room temperature rises above the user-set temperature. Before the compressor starts, the fan motor will run for a while, then it will stop for a while, and will repeat to provide a much more comfortable feeling and save energy.

7. **Sleep Button:** Press the SLEEP button, all of the display lights will turn off after a while, but the Sleep light is always on. In SLEEP mode, the air conditioner will automatically adjust the temperature and fan speed to make the room more comfortable during the night. The set temperature will automatically raise every 30-60 minutes, and at most change six times until the set temperature is 81 or 82°F for cooling and 75 or 76°F for heating.

8. **Fan Speed Button:** Press the FAN SPEED button to choose the fan speed options. You can choose Hi, Med, Lo or auto speed in COOL mode or HEAT mode and choose Hi, Med, Lo in FAN mode.

9. **Filter Button:**

When the Filter Check light is on, you can turn off the light by pressing the Filter Check button. After the fan motor works for 500 total hours, the Filter Check light will turn on to remind the user to clean the filter. When the Filter Check light is off, it is not necessary to press the Filter Check button.

10. **Directional Louvers:** To direct the airflow, use the horizontal wheel to control the horizontal direction, and use the air deflectors to control the vertical direction.

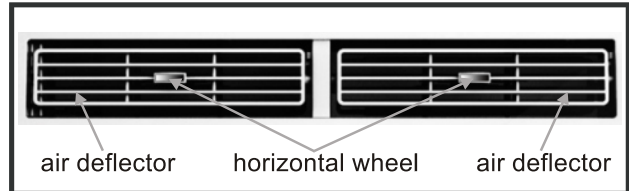

# OPERATION

## Sequence of Operation

### Main function

#### NOTES:

RT-----Room Temperature.

IPT-----Indoor Pipe (Coil) Temperature.

ST-----indoor Set Temperature.

OPT---Outdoor Pipe (Coil) Temperature.

CRT---Compensated Room Temperature

### 1. Cooling mode

In the cooling mode, COOL indicator is ON, the set temperature and fan speed could be changed or adjusted.

a. When  $RT-ST \geq 33.8^{\circ}F$  the compressor operates if there is not any protection or failure happened.

b. When  $RT-ST < 30.2^{\circ}F$  the compressor stops, and fan motor keeps operation continuous.

c. When  $30.2^{\circ}F \leq RT-ST < 33.8^{\circ}F$  the compressor keeps former status.

#### 1.1 Indoor fan motor control

1.1.1 Indoor fan motor could be controlled by Auto, Low, Med and High speed circularly .

1.1.2 Indoor fan motor Auto control as below:

a) In cooling mode  $\Delta T = RT - ST$

b) While  $\Delta T < 32^{\circ}F$ , operates in low speed;

c) If  $\Delta T = 35.6^{\circ}F$ , in medium speed

d) If  $\Delta T \geq 39.2^{\circ}F$ , in high speed

e) If  $35.6^{\circ}F < \Delta T < 39.2^{\circ}F$ , The fan motor runs at original speed while it was set in High or Med mode. If at Low speed, it will change to Med speed automatically.

f) If  $32^{\circ}F \leq \Delta T < 35.6^{\circ}F$ , The fan motor operates at original speed while it was set in Low or Med mode. If original at High speed, it will change to Med automatically.

g) When fan speed changes due to the temperature variation, it could be changed only by sequence as

to Low speed or Low, Med to High speed, and each status will keep at least 2 minutes.

original

High, Med

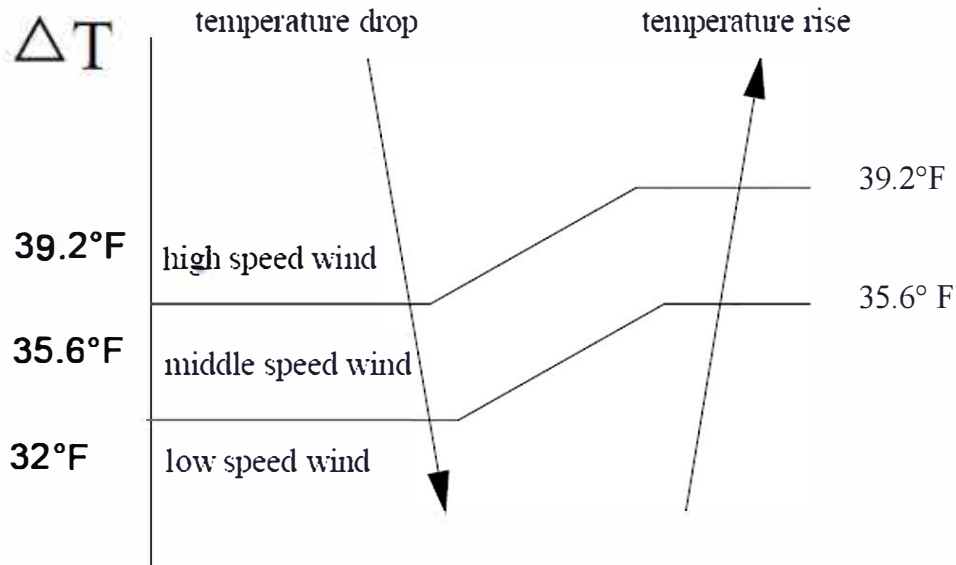

# OPERATION

## Sequence of Operation

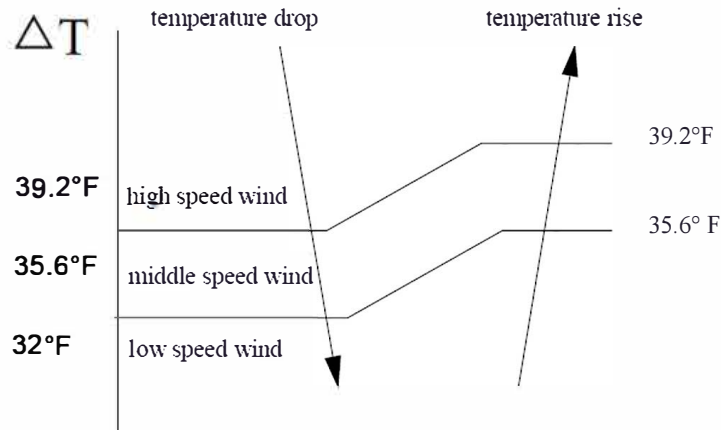

Auto fan speed in cooling mode

### 2. Dry mode

While selected to Dry mode, AC works at set temperature to 44.6°F for 3 minutes. After that the set temperature change to be RT 28.4°F, the compressor works as cooling mode, and indoor fan motor operates at low speed. The fan speed can not be changed while in dry mode, but the air direction can be adjusted.

### 3. I FEEL Mode

3.1 The operation mode and initial ST are generated by the Initial RT, and the operation mode is enabled once unless AC is switched off and powered on again. While I FEEL is changed from other mode, the AC will operate based on the RT temperature judgement.

3.2 PCB with Auto Restart Function, while power on again,

- a). With Auto Restart Function activated, AC runs according to the temperature judgement.
- b). If without Auto Restart Function or the function is shut off, AC works on stand by.

Operation MODE	Initial RT	Initial ST
<u>Cooling</u>	RT ≥ 78.8°F	73.4°F
<u>Dry</u>	78.8°F > RT ≥ 35.6°F	RT- 28.4°F
<u>Heating</u> for Heat Pump or <u>Fan</u> for Cooling Only.	RT < 35.6°F	73.4°F

When AC works in Dry mode after judgement, the display temperature ranges from 3.2°F to 87.8°F, and the set temperature ranges from 41°F to 87.8°F.

When AC works in Fan mode, the set temperature is fixed to 73.4°F, and displays room temperature.

In I FEEL mode (I FEEL cooling or heating), and the PCB receives instructions of temperature adjustment as increasing or decreasing from remote control, the unit sets ST as the current room temperature ± 1°F.

( in heating mode, the RT need to be compensated), I FEEL temperature adjusts : ± 3.6°F and buzzer responds but controller takes no action. The set temperature range is from: 60.8°F - 87.8°F.

Only works on Cooling or Heating of I FEEL mode, the unit has above temperature control process. In I FEEL Dry or Fan mode, the buzzer responds, but does not have control of any other operation.



# OPERATION

## Sequence of Operation

### 4. Heating mode (for Cooling & Heating pump)

When in heating operation mode, the set temperature, fan speed and air direction can be adjusted, compressor does not operate, but electrical heater works, and indoor fan motor starts up 10s later.

a  $ST-RT \geq 33.8^\circ F$  electrical heater operates

b  $ST-RT < 30.2^\circ F$  electrical heater stops.

c  $30.2^\circ F \leq ST-RT < 33.8^\circ F$  electrical heater keeps the original works status .

#### Indoor fan motor control

4.1 Indoor fan motor could control by Auto, Low, Med or High speed circularly.

4.2 Indoor fan motor Auto works as follow:

a) In heating mode:  $\Delta T = ST - CRT$

b)  $\Delta T = 32^\circ F$ , running in low speed

c)  $\Delta T = 35.6^\circ F$ , in medium speed

d)  $\Delta T \geq 39.2^\circ F$ , in high speed .

e)  $35.6^\circ F < \Delta T < 39.2^\circ F$ , the fan speed keeps in medium or high speed as it's originally preset, but if the fan was originally in low speed, it will change to medium.

f)  $32^\circ F \leq \Delta T < 35.6^\circ F$ , the fan speed keeps in low or medium speed as it's originally preset, if fan in high speed, it will change to medium speed.

g) When fan speed changes due to the temperature variation , it could be changed only by sequence as High, Med to Low speed or Low, Med to High speed , and each status keeps at least 2 minutes.

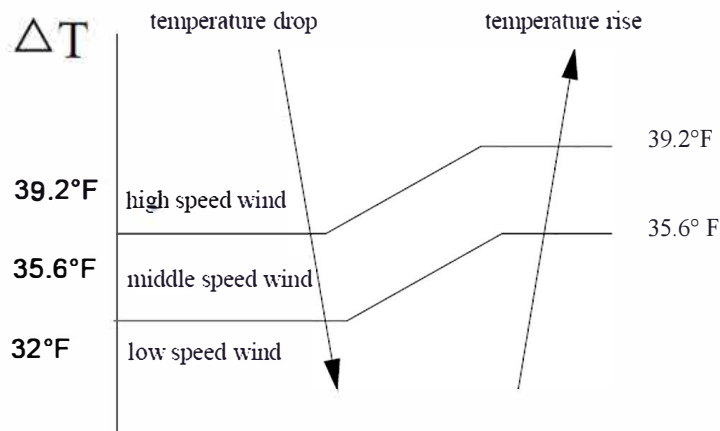

## 5. Fan mode

In FAN mode, the corresponding indicator is ON, fan motor runs according to the set speed (default High speed for the first time), compressor doesn't work, Buzzer and PCB do not respond while pressing the UP/DOWN button on remote controller, the fan motor is adjustable in high, medium or low speed, but no auto wind, 88 digital display shows environment temperature.

## 6. Sleep mode

6.1 In SLEEP mode, the indoor fan motor runs at low speed, except that the power source and sleep LED is ON, the running LED and others light are OFF, the condition of timer LED is according to the preset, and all the LEDs will be OFF after 30 seconds.

6.2 Temperature control

Processing SLEEP while in Cooling or Heating mode, unit runs according to the sleeping operation.

Item	initial set temp. (F)	The 1st change		The 2nd change		The 3rd change		The 4th change		The 5th change		The 6th change	
		runing time	ST(F)	runing time	ST(F)	runing time	ST(F)	runing time	ST(F)	runing time	ST(F)	runing time	ST(F)
The controlled set temperature. Note:unit--- Time: minute	$\geq 82$	60	no change	60	no change	60	no change	60	no change	60	no change	60	no change
	80	60	82	60	no change	60	no change	60	no change	60	no change	60	no change
	78	50	80	60	82	60	no change	60	no change	60	no change	60	no change
	77	40	78	50	80	60	no change	60	no change	60	no change	60	no change
	75	30	77	40	78	50	80	60	no change	60	no change	60	no change
	73	30	75	30	77	40	78	50	80	60	no change	60	no change
	71	30	73	30	75	30	77	40	78	50	80	60	no change
$\leq 70$	0 3	4	30	5 8	0 5	75	0 5	9 1	0 4	10 9	0 5	80	
Fan speed	set speed	set speed		low speed		low-low speed							
UP/DOWN swing	ON/OFF	keep original		keep angle for cold air prevention									

# OPERATION

## Sequence of Operation

- a) The indoor fan runs at the set speed when processing sleep mode, after the 1st change, unit runs at low speed, and after the 2nd change, unit runs at low-low speed ( if AC without low-low speed, it runs at low speed instead). 10 hours later AC quits from sleep mode and runs at former set fan speed .
- b) In SLEEP mode, the vane works according to the preset, after the first change, vane blade works at cold air prevention angle. 10 hours later AC quits from sleep and works as the former preset.
- c) The set fan speed refers to the preset value before processing SLEEP mode. If the unit just on stand by before sleep operation, the set value to be according to low speed . If AC preset in super speed, the set value will change to high speed, while in Auto wind, it will change to low speed.

## B. Sleep mode on Heating operation:

table 2

Item	initial set temp. (F)	The 1st change		The 2nd change		The 3rd change		The 4th change		The 5th change		The 6th change	
		runing time	ST(F)	runing time	ST(F)	runing time	ST(F)	runing time	ST(F)	runing time	ST(F)	runing time	ST(F)
The controlled set temperature. Note:unit— Time: minute	≥82	60	12.9	0.6	78	0.6	9.3	60	no change	60	no change	60	no change
	80	60	78	60	77	60	75	60	no change	60	no change	60	no change
	78	60	77	60	75	60	no change	60	no change	60	no change	60	no change
	77	60	75	60	no change	60	no change	60	no change	60	no change	60	no change
	≤75	60	no change	60	no change	60	no change	60	no change	60	no change	60	no change
Fan speed	set speed	set speed		only High speed change to Med speed, otherwise keep the set fan speed									
UP/DOWN swing	ON/OFF	keep original											

- 1) The indoor fan runs at the set speed when processing in sleep mode, after the first change, unit changes to medium speed if the preset is in high operation, and the medium and low speed preset will keep the original even after the first change. 10 hours later AC quits from sleep mode and runs at former set fan speed
- 2) Processing SLEEP mode, the vane works according to the preset, 10 hours later AC quits from sleep and works as the former preset.
- 3) The set fan speed refers to the preset value before processing SLEEP mode. If the unit just on stand by before sleep operation, the set value to be according to low speed. if AC preset in super speed, the set value will change to high speed, while in Auto wind, it change to low speed.

## Sleep process control

- 1) If the set temperature is changed during the period of sleep mode, it is also executed as the initial sleep set, and the change time is reset to 0, the temperature change will be restarted, but the 10 hours running time will not be reset as 0, it will accumulate continuously.
- 2) The fan speed can not be changed during sleep mode.
- 3) During the sleep period in cooling mode, the new set will be executed if the vane work status is changed, the anti-cold angle will not be executed.
- 4) During the sleep period in heating mode, the wind speed and vane swinging for cold air prevention function is selected first.

## The sleep instruction in Cooling or Heating of I FEEL mode

- 1) The current set temperature is set as initial value if sleep mode has not been set before processing sleep mode.
- 2) If the set temperature is changed, the change times is reset to 0, the new set temperature will be executed, 10 hours timing will be continued.
- 3) There is other operation during sleep mode, e.g. vane operation, AC keeps operation continuously with the initial value no exchanged.
- 4) The sleep mode category is changed during sleep operation, the initial set temperature in cooling or heating of I FEEL mode will be set as initial running value if no temperature adjustment; or the temperature after increased or decreased will be set as initial running value after temperature adjustment; and the change times is reset to 0, 10 hours timing accumulation will be restarted.
- 5) The unit works according to the new set temperature when operating remote controller or other controller to quit sleep mode.

## 7. Auto Restart Function (Optional)

- 7.1 PCB with auto restart function will keep the operation parameters in EEPROM even with power off. And the unit can restore operation as the former status automatically while power is on.
- 7.2 The status parameters include the set mode, fan speed, set temperature and the vane blade position when unit is off (the swinging status will be remembered when the vane was set as swinging)
- 7.3 Pressing sleep button 10 times within 8 seconds during running status, the Auto Restart Function could be activated or turned off; The buzzer sounds 3 times BIBI when activated and 4 times BIBI when function is turned off (operate with remote controller).

## 8. ECO function

- 8.1 The adjustable temperature: 16°C-31°C or 61°F-88°F.
- 8.2 The action temperature and running of compressor is the same as cooling mode.
- 8.3 The fan speed setting and other assistant function same as cooling mode.

---

# OPERATION

## Sequence of Operation

- 8.4 The indoor fan motor works as below while RT meets the set temperature to stop compressor:
- The indoor fan motor runs for 1 min according to the set speed continuously, and then stops.
  - The indoor fan keeps the stopping status in the following 10 min if RT meets the requirement of compressor stopping work.
  - After 10 min, the indoor fan motor runs for 20 seconds and lets the indoor air flow through the evaporator.
  - The indoor fan works as step b) and c) circularly.
  - During above process, if RT increase or ST decrease, also RT meet the requirement of compressor need to work, the unit exits above b), c) & d) circulation----indoor fan motor operation immediately at set speed, and compressor also starts up while three-min protection is met.
  - If the compressor working condition is not met after switching on the unit, the indoor fan runs at set speed for 1 min, then runs as step b) and c) circularly; If the compressor working condition is met after switching on the unit, the indoor fan runs at set speed
  - In above circulation, the 3-min protection for compressor always function.

## 9. Filter cleaning function

- The LED for air FILTER will light (ON) when the indoor fan motor work has accumulated 500 hours.
- Pressing the FILTER button means cleaning is finished, the accumulation hours are reset to 0 and start timing again, the FILTER indicator OFF.
- 500 accumulation hours could be reset to 0 by pressing the filter cleaning button only.
- There is no effect on the AC operation even when the filter indicator is ON.

## Assistance function

- Display and Key button  
Display: default indicates set temperature (ST).  
The key buttons include POWER (ON/OFF), FAN, MODE, UP, DOWN, TIMER, SLEEP, ECO, FILTER cleaning and HEALTH, the buzzer BIBI response for each valid button pressing.

The detailed instructions are below:

## POWER ON/OFF button

When switched on, the indicator displays current set value and the running status can be adjusted by pressing buttons; there is no display when turned off, press FAN, UP, DOWN and MODE button is invalid; In timer mode, the timer indicator ON and digital LED displays the remained time, no other indicator, FAN and MODE button invalid. Pressing ON/OFF button may cancel the timer function. (Note: The Auto Restart Function default activated after production in the factory.)

## FAN speed button

Pressing the FAN speed button causes switchover as:



## MODE button

Cooling Only: Cooling -Dry - Fan - Auto.  
Cooling & Heating pump : Cooling - Dry - Fan - Heat - Auto.

## UP / DOWN button

It is used for temperature preset and timer adjustment.  
When pressing the UP or DOWN button, buzzer response, and the digital display the set temperature or the set time.  
In the running status, press SLEEP button 6 times within 8 seconds will be ON or OFF the room temperature display, the buzzer shortly BIBI twice. (by remote controller)

## TIMER button

When unit is working (without time set), press TIMER button to set the AC time to shut down, the timer indicator ON.  
When unit is OFF, press TIMER button to set the time of AC power on, the timer indicator ON  
The timer can be set from 0.5, 1.0, 1.5, 2.0, .....10, 11, 12..... to 24 hours, it could circulate by dual direction: when showing 0.5, pressing DOWN button, the time changes to 24, vice versa, when showing 24, pressing UP button, the time changes to 0.5.  
When 88 digital display timer, press UP/DOWN to adjust the timing time, the number flashes and 10s later, the digital recovery to display the set temperature. In order to regulate timer quickly in timing mode, pressing the UP/DOWN button for 2 seconds to trigger continuous adjustment with the frequency 5Hz.

## FILTER button

When filter light is ON, pressing this button, the light will be OFF. It will be meaningless to press this button while the light is OFF.

## HEALTH button

Pressing this button to turn on anion function, if pressing once more time to shut off anion.

## 2 BUZZER function

---

# OPERATION

## Sequence of Operation

Power on controller: Buzzer buzzing once for 0.3s.

Power off unit: Buzzer buzzing once.

Pressing button and/or receiving signal: Buzzer BIBI shortly once.

Malfunction: buzzer BIBI shortly 3 times

## Protection / Failure code

### 1 Anti-frozen protection for indoor evaporator:

If  $IPT \leq 32^{\circ}\text{F}$  for continuous 3min, compressor shut off, fan motor keeps former operation; 3min later, if  $IPT \geq 50^{\circ}\text{F}$ , compressor start up operation and fan motor keeps the former running status.

### 2 SENSOR error protection

When sensor short circuit or broken, Room Temperature failure shows E1, and Coil Temperature failure shows E2. When E1 or E2 happened, compressor stops and indoor fan motor operates at the set speed.

When AC on STANDBY, there is no malfunction inspection.

The NTC sensor resistance:  $5\text{k}\Omega / 77^{\circ}\text{F}$

3 Compressor protection

If unit is on STANDBY before power off, there is no 3-min protection while switch on, otherwise the unit always has 3-min protection.

### 4 SELF-DIAGNOSIS function

Press the ON/OFF button first, and then switching on unit. AC works and checks as below accordingly:

Buzzer BIBI 2 times, 88 Digital fully lights, Electric heating (for cooling & heating) , Compressor , High fan speed ,Medium speed ,Low speed , Health , WIFI LED, indicator of Heat/Cool /High speed/Dry / Medium speed / Low speed/Auto fan/ Timing / Sleep/ Filter cleaning/ ECO/Health, Room temperature , Indoor coil Temperature , EEPROM calibration etc.

After self-diagnosis, unit to STANDBY (Note: unit with auto restart function will operate according to it's former status)

# OPERATION

## Refrigeration Sequence Of Operation

A good understanding of the basic operation of the refrigeration system is essential for the service technician. Without this understanding, accurate troubleshooting of refrigeration system problems will be more difficult and time consuming, if not (in some cases) entirely impossible. The refrigeration system uses four basic principles (laws) in its operation they are as follows:

1. "Heat always flows from a warmer body to a cooler body."
2. "Heat must be added to or removed from a substance before a change in state can occur"
3. "Flow is always from a higher pressure area to a lower pressure area."
4. "The temperature at which a liquid or gas changes state is dependent upon the pressure."

The refrigeration cycle begins at the compressor. Starting the compressor creates a low pressure in the suction line which draws refrigerant gas (vapor) into the compressor. The compressor then "compresses" this refrigerant vapor, raising its pressure and its (heat intensity) temperature.

The refrigerant leaves the compressor through the discharge Line as a hot High pressure gas (vapor). The refrigerant enters the condenser coil where it gives up some of its heat. The condenser fan moving air across the coil's finned surface facilitates the transfer of heat from the refrigerant to the relatively cooler outdoor air.

When a sufficient quantity of heat has been removed from the refrigerant gas (vapor), the refrigerant will "condense" (i.e. change to a liquid). Once the refrigerant has been condensed (changed) to a liquid it is cooled even further by the air that continues to flow across the condenser coil.

The design determines at exactly what point (in the condenser) the change of state (i.e. gas to a liquid) takes place. In all cases, however, the refrigerant must be totally condensed (changed) to a Liquid before leaving the condenser coil.

The refrigerant leaves the condenser Coil through the liquid line as a warm high pressure liquid. It next will pass through the refrigerant drier (if equipped). It is the function of the drier to trap any moisture present in the system, contaminants, and large particulate matter.

The liquid refrigerant next enters the metering device. The metering device is a capillary tube. The purpose of the metering device is to "meter" (i.e. control or measure) the quantity of refrigerant entering the evaporator coil. In the case of the capillary tube this is accomplished (by design) through size (and length) of device, and the pressure difference present across the device.

Since the evaporator coil is under a lower pressure (due to the suction created by the compressor) than the liquid line, the liquid refrigerant leaves the metering device entering the evaporator coil. As it enters the evaporator coil, the larger area and lower pressure allows the refrigerant to expand and lower its temperature (heat intensity). This expansion is often referred to as "boiling" or atomizing. Since the unit's blower is moving indoor air across the finned surface of the evaporator coil, the expanding refrigerant absorbs some of that heat. This results in a lowering of the indoor air temperature, or cooling.

The expansion and absorbing of heat cause the liquid refrigerant to evaporate (i.e. change to a gas). Once the refrigerant has been evaporated (changed to a gas), it is heated even further by the air that continues to flow across the evaporator coil.

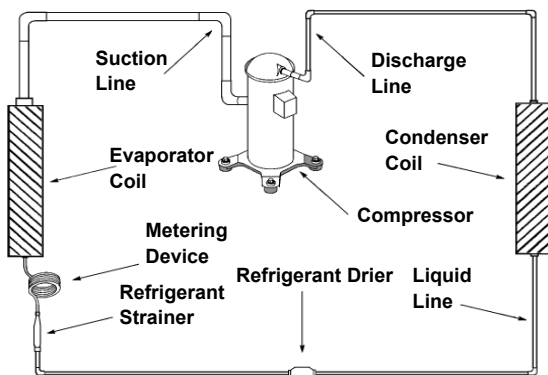

The particular system design determines at exactly what point (in the evaporator) the change of state (i.e. liquid to a gas) takes place. In all cases, however, the refrigerant must be totally evaporated (changed) to a gas before leaving the evaporator coil.

The low pressure (suction) created by the compressor causes the refrigerant to leave the evaporator through the suction line as a cool low pressure vapor. The refrigerant then returns to the compressor, where the cycle is repeated.

**Figure 341 (Refrigeration Sequence Of Operation)**

# R-410A SEALED SYSTEM REPAIR

## WARNING

### Refrigeration system under high pressure



Do not puncture, heat, expose to flame or incinerate.  
Only certified refrigeration technicians should service this equipment.  
R410A systems operate at higher pressures than R22 equipment. Appropriate safe service and handling practices must be used.  
Only use gauge sets designed for use with R410A.  
Do not use standard R22 gauge sets.

### The following is a list of important considerations when working with R-410A equipment

1. R-410A pressure is approximately 60% higher than R-22 pressure.
  2. R-410A cylinders must not be allowed to exceed 125 F, they may leak or rupture.
  3. R-410A must never be pressurized with a mixture of air, it may become flammable.
  4. Servicing equipment and components must be specifically designed for use with R-410A and dedicated to prevent contamination.
5. Manifold sets must be equipped with gauges capable of reading 750 psig (high side) and 200 psig (low side), with a 500-psig low-side retard.
  6. Gauge hoses must have a minimum 750-psig service pressure rating
  7. Recovery cylinders must have a minimum service pressure rating of 400 psig, (DOT 4BA400 and DOT BW400 approved cylinders).
  8. POE (Polyol-Ester) lubricants must be used with R-410A equipment.
  9. To prevent moisture absorption and lubricant contamination, do not leave the refrigeration system open to the atmosphere longer than 1 hour.
  10. Weigh-in the refrigerant charge into the high side of the system.
  11. Introduce liquid refrigerant charge into the high side of the system.
  12. For low side pressure charging of R-410A, use a charging adaptor.
  13. Use Friedrich approved R-410A filter driers only.

## IMPORTANT

SEALED SYSTEM REPAIRS TO COOL-ONLY MODELS REQUIRE THE INSTALLATION OF A LIQUID LINE DRIER.

### EQUIPMENT REQUIRED:

1. Voltmeter
2. Ammeter
3. Ohmmeter
4. E.P.A. Approved Refrigerant Recovery System
5. Vacuum Pump (capable of 200 microns or less vacuum.)
6. Acetylene Welder
7. Electronic Halogen Leak Detector capable of detecting HFC (Hydrofluorocarbon) refrigerants.
8. Accurate refrigerant charge measuring device such as:
  - a. Balance Scales - 1/2 oz. accuracy
  - b. Charging Board - 1/2 oz. accuracy
9. High Pressure Gauge - (0 to 750 lbs.)
10. Low Pressure Gauge - (-30 to 200 lbs.)
11. Vacuum Gauge - (0 - 1000 microns)
12. Facilities for flowing nitrogen through refrigeration tubing during all brazing processes.

### EQUIPMENT MUST BE CAPABLE OF:

1. Recovering refrigerant to EPA required levels.
2. Evacuation from both the high side and low side of the system simultaneously.
3. Introducing refrigerant charge into high side of the system.
4. Accurately weighing the refrigerant charge introduced into the system.

---

# R-410A SEALED SYSTEM REPAIRS

<b>⚠ WARNING</b>	
	<b>RISK OF ELECTRIC SHOCK</b> Unplug and/or disconnect all electrical power to the unit before performing inspections, maintenances or service.  Failure to do so could result in electric shock, serious injury or death.

<b>⚠ WARNING</b>	
	<b>HIGH PRESSURE HAZARD</b> Sealed Refrigeration System contains refrigerant and oil under high pressure.  Proper safety procedures must be followed, and proper protective clothing must be worn when working with refrigerants.  Failure to follow these procedures could result in serious injury or death.

## Refrigerant Charging

NOTE: Because the refrigerant system is a sealed system, service process tubes will have to be installed. First install a line tap and remove refrigerant from system. Make necessary sealed system repairs and vacuum system. Crimp process tube line and solder end shut. Do not leave a service valve in the sealed system.

Proper refrigerant charge is essential to proper unit operation. Operating a unit with an improper refrigerant charge will result in reduced performance (capacity) and/or efficiency. Accordingly, the use of proper charging methods during servicing will insure that the unit is functioning as designed and that its compressor will not be damaged.

Too much refrigerant (overcharge) in the system is just as bad (if not worse) than not enough refrigerant (undercharge). They both can be the source of certain compressor failures if they remain uncorrected for any period of time. Quite often, other problems (such as low air flow across evaporator, etc.) are misdiagnosed as refrigerant charge problems. The refrigerant circuit diagnosis chart will assist you in properly diagnosing these systems.

An overcharged unit will at times return liquid refrigerant (slugging) back to the suction side of the compressor eventually causing a mechanical failure within the compressor. This mechanical failure can manifest itself as valve failure, bearing failure, and/or other mechanical failure. The specific type of failure will be influenced by the amount of liquid being returned, and the length of time the slugging continues.

Not enough refrigerant (undercharge) on the other hand, will cause the temperature of the suction gas to increase to the point where it does not provide sufficient cooling for the compressor motor. When this occurs, the motor winding temperature will increase causing the motor to overheat and possibly cycle open the compressor overload protector. Continued overheating of the motor windings and/or cycling of the overload will eventually lead to compressor motor or overload failure.

# R-410A SEALED SYSTEM REPAIRS

<b>⚠ WARNING</b>	
	<b>RISK OF ELECTRIC SHOCK</b> Unplug and/or disconnect all electrical power to the unit before performing inspections, maintenances or service.  Failure to do so could result in electric shock, serious injury or death.

## Undercharged Refrigerant Systems

An undercharged system will result in poor performance (low pressures, etc.) in both the heating and cooling cycle.

Whenever you service a unit with an undercharge of refrigerant, always suspect a leak. The leak must be repaired before charging the unit.

To check for an undercharged system, turn the unit on, allow the compressor to run long enough to establish working pressures in the system (15 to 20 minutes).

During the cooling cycle you can listen carefully at the exit of the metering device into the evaporator; an intermittent hissing and gurgling sound indicates a low refrigerant charge. Intermittent frosting and thawing of the evaporator is another indication of a low charge, however, frosting and thawing can also be caused by insufficient air over the evaporator.

Checks for an undercharged system can be made at the compressor. If the compressor seems quieter than normal, it is an indication of a low refrigerant charge.

A check of the amperage drawn by the compressor motor should show a lower reading. (Check the Unit Specification.) After the unit has run 10 to 15 minutes, check the gauge pressures. Gauges connected to system with an undercharge will have low head pressures and substantially low suction pressures.

<b>⚠ WARNING</b>	
	<b>HIGH PRESSURE HAZARD</b> Sealed Refrigeration System contains refrigerant and oil under high pressure.  Proper safety procedures must be followed, and proper protective clothing must be worn when working with refrigerants.  Failure to follow these procedures could result in serious injury or death.

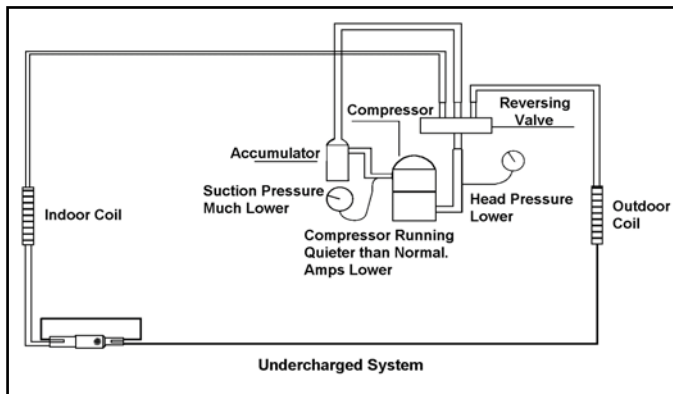



Figure 601 (Undercharged System)



# R-410A SEALED SYSTEM REPAIRS

<b>⚠ WARNING</b>	
	<b>RISK OF ELECTRIC SHOCK</b> Unplug and/or disconnect all electrical power to the unit before performing inspections, maintenances or service.
	Failure to do so could result in electric shock, serious injury or death.

## Overcharged Refrigerant Systems

Compressor amps will be near normal or higher. Noncondensables can also cause these symptoms. To confirm, remove some of the charge, if conditions improve, system may be overcharged. If conditions don't improve, Noncondensables are indicated.

Whenever an overcharged system is indicated, always make sure that the problem is not caused by air flow problems. Improper air flow over the evaporator coil may indicate some of the same symptoms as an over charged system.

An overcharge can cause the compressor to fail, since it would be "slugged" with liquid refrigerant. The charge for any system is critical. When the compressor is noisy, suspect an overcharge, when you are sure that the air quantity over the evaporator coil is correct. Icing of the evaporator will not be encountered because the refrigerant will boil later if at all. Gauges connected to system will usually have higher head pressure (depending upon amount of over charge). Suction pressure should be slightly higher.

<b>⚠ WARNING</b>	
	<b>HIGH PRESSURE HAZARD</b> Sealed Refrigeration System contains refrigerant and oil under high pressure.
	Proper safety procedures must be followed, and proper protective clothing must be worn when working with refrigerants.
	Failure to follow these procedures could result in serious injury or death.

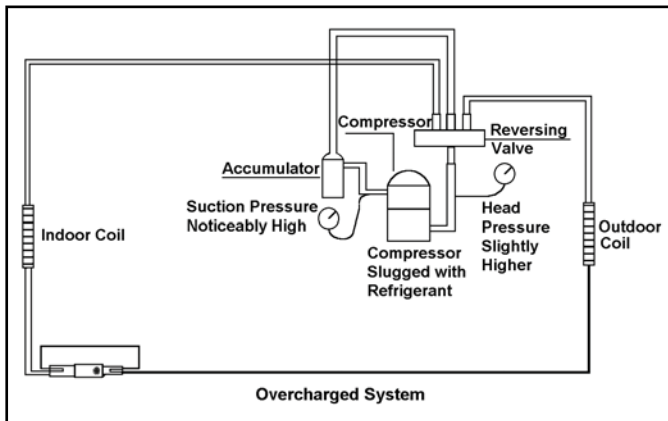

**Figure 602 (Overcharged System)**

# R-410A SEALED SYSTEM REPAIRS

## Restricted Refrigerant System

Troubleshooting a restricted refrigerant system can be difficult. The following procedures are the more common problems and solutions to these problems. There are two types of refrigerant restrictions: Partial restrictions and complete restrictions.

A partial restriction allows some of the refrigerant to circulate through the system.

With a complete restriction there is no circulation of refrigerant in the system. Restricted refrigerant systems display the same symptoms as a "low-charge condition."

When the unit is shut off, the gauges may equalize very slowly.

Gauges connected to a completely restricted system will run in a deep vacuum. When the unit is shut off, the gauges will not equalize at all.

A quick check for either condition begins at the evaporator. With a partial restriction, there may be gurgling sounds at the metering device entrance to the evaporator. The evaporator in a partial restriction could be partially frosted or have an ice ball close to the entrance of the metering device. Frost may continue on the suction line back to the compressor.

Often a partial restriction of any type can be found by feel, as there is a temperature difference from one side of the restriction to the other.

With a complete restriction, there will be no sound at the metering device entrance. An amperage check of the compressor with a partial restriction may show normal current when compared to the unit specification. With a complete restriction the current drawn may be considerably less than normal, as the compressor is running in a deep vacuum (no load.) Much of the area of the condenser will be relatively cool since most or all of the liquid refrigerant will be stored there.

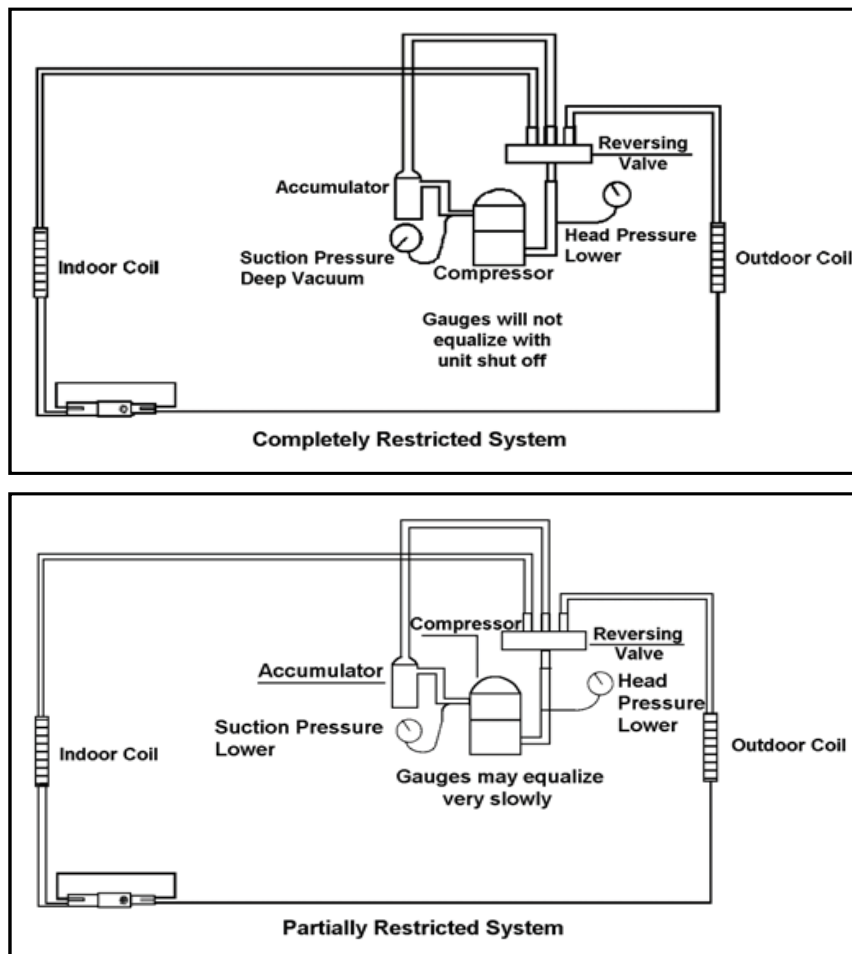



Figure 603 (Restricted System)

---

# R-410A SEALED SYSTEM REPAIRS

## Sealed System Method of Charging/ Repairs

<b>⚠ WARNING</b>		<b>⚠ CAUTION</b>	
	<b>BURN HAZARD</b> Proper safety procedures must be followed, and proper protective clothing must be worn when working with a torch.  Failure to follow these procedures could result in moderate or serious injury.		<b>FREEZE HAZARD</b> Proper safety procedures must be followed, and proper protective clothing must be worn when working with liquid refrigerant.  Failure to follow these procedures could result in minor to moderate injury.

The acceptable method for charging the sealed system is the Weighed in Charge Method. The weighed in charge method is applicable to all units. It is the preferred method to use, as it is the most accurate.

The weighed in method should always be used whenever a charge is removed from a unit such as for a leak repair, compressor replacement, or when there is no refrigerant charge left in the unit. To charge by this method, requires the following steps:

1. Install a piercing valve to remove refrigerant from the sealed system. (Piercing valve must be removed from the system before recharging.)
2. Recover Refrigerant in accordance with EPA regulations.
3. Install a process tube to sealed system.
4. Make necessary repairs to system.
5. Evacuate system to 200 microns or less.
6. Weigh in refrigerant with the property quantity of R-410A refrigerant.
7. Start unit, and verify performance.
8. Crimp the process tube and solder the end shut.

# COMPONENT TESTING

## Hermetic Components Check

<b>⚠ WARNING</b>	
	<p><b>BURN HAZARD</b></p> <p>Proper safety procedures must be followed, and proper protective clothing must be worn when working with a torch.</p> <p>Failure to follow these procedures could result in moderate or serious injury.</p>

<b>⚠ WARNING</b>	
	<p><b>CUT/SEVER HAZARD</b></p> <p>Be careful with the sharp edges and corners. Wear protective clothing and gloves, etc.</p> <p>Failure to do so could result in serious injury.</p>

### Metering Device - Capillary Tube Systems

All units are equipped with capillary tube metering devices. Checking for restricted capillary tubes.

1. Connect pressure gauges to unit.
2. Start the unit in the cooling mode. If after a few minutes of operation the pressures are normal, the check valve and the cooling capillary are not restricted.
3. Switch the unit to the heating mode and observe the gauge readings after a few minutes running time. If the system pressure is lower than normal, the heating capillary is restricted.
4. If the operating pressures are lower than normal in both the heating and cooling mode, the cooling capillary is restricted.

### Check Valve

A unique two-way check valve is used on the reverse cycle heat pumps. It is pressure operated and used to direct the flow of refrigerant through a single filter drier and to the proper capillary tube during either the heating or cooling cycle.

**NOTE:** The slide (check) inside the valve is made of teflon. Should it become necessary to replace the check valve, place a wet cloth around the valve to prevent overheating during the brazing operation.

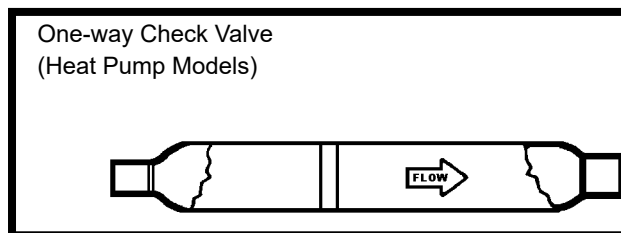

**Figure 701 (Check Valve)**

### CHECK VALVE OPERATION

In the cooling mode of operation, high pressure liquid enters the check valve forcing the slide to close the opposite port (liquid line) to the indoor coil. Refer to refrigerant flow chart. This directs the refrigerant through the filter drier and cooling capillary tube to the indoor coil.

In the heating mode of operation, high pressure refrigerant enters the check valve from the opposite direction, closing the port (liquid line) to the outdoor coil. The flow path of the refrigerant is then through the filter drier and heating capillary to the outdoor coil.

Failure of the slide in the check valve to seat properly in either mode of operation will cause flooding of the cooling coil. This is due to the refrigerant bypassing the heating or cooling capillary tube and entering the liquid line.

### COOLING MODE

In the cooling mode of operation, liquid refrigerant from condenser (liquid line) enters the cooling check valve forcing the heating check valve shut. The liquid refrigerant is directed into the liquid dryer after which the refrigerant is metered through cooling capillary tubes to evaporator. (Note: liquid refrigerant will also be directed through the heating capillary tubes in a continuous loop during the cooling mode).

### HEATING MODE

In the heating mode of operation, liquid refrigerant from the indoor coil enters the heating check valve forcing the cooling check valve shut. The liquid refrigerant is directed into the liquid dryer after which the refrigerant is metered through the heating capillary tubes to outdoor coils. (Note: liquid refrigerant will also be directed through the cooling capillary tubes in a continuous loop during the heating mode).

# COMPONENT TESTING

## Reversing valve description and operation

The Reversing Valve controls the direction of refrigerant flow to the indoor and outdoor coils. It consists of a pressure-operated, main valve and a pilot valve actuated by a solenoid plunger. The solenoid is energized during the heating cycle only. The reversing valves used in the RAC system is a 2-position, 4-way valve.

The single tube on one side of the main valve body is the high-pressure inlet to the valve from the compressor. The center tube on the opposite side is connected to the low pressure (suction) side of the system. The other two are connected to the indoor and outdoor coils. Small capillary tubes connect each end of the main valve cylinder to the "A" and "B" ports of the pilot valve. A third capillary is a common return line from these ports to the suction tube on the main valve body. Four-way reversing valves also have a capillary tube from the compressor discharge tube to the pilot valve.

The piston assembly in the main valve can only be shifted by the pressure differential between the high and low sides of the system. The pilot section of the valve opens and closes ports for the small capillary tubes to the main valve to cause it to shift.

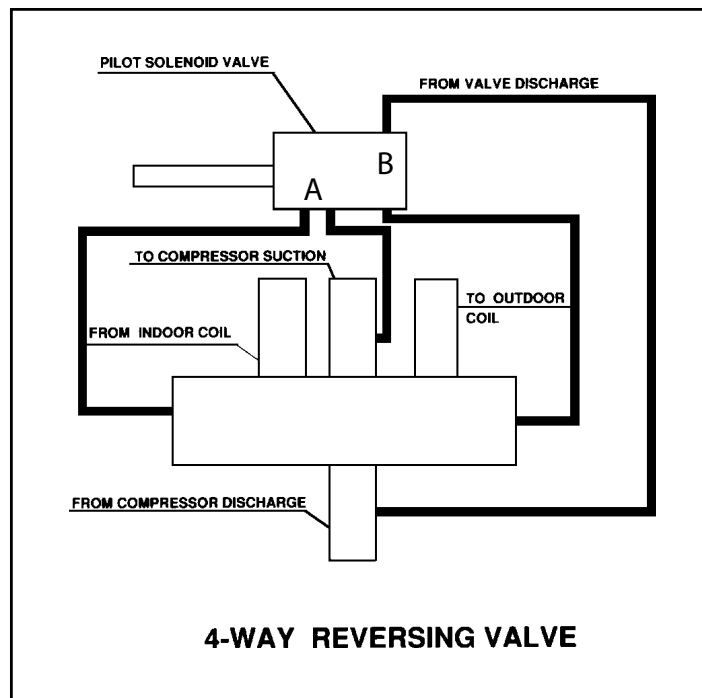



Figure 702 (Reversing Valve)

---

# COMPONENT TESTING

## Testing The Reversing Valve Solenoid Coil

⚠ WARNING	
	<b>ELECTRIC SHOCK HAZARD</b> Disconnect power to the unit before servicing. Failure to follow this warning could result in serious injury or death.

The solenoid coil is an electromagnetic type coil mounted on the reversing valve and is energized during the operation of the compressor in the heating cycle.

1. Turn off high voltage electrical power to unit.
2. Unplug line voltage lead from reversing valve coil.
3. Check for electrical continuity through the coil. If you do not have continuity replace the coil.
4. Check from each lead of coil to the copper liquid line as it leaves the unit or the ground lug. There should be no continuity between either of the coil leads and ground; if there is, coil is grounded and must be replaced.
5. If coil tests okay, reconnect the electrical leads.
6. Make sure coil has been assembled correctly.

**NOTE: Do not start unit with solenoid coil removed from valve, or do not remove coil after unit is in operation. This will cause the coil to burn out.**

### Touch Test in Heating/Cooling Cycle

⚠ WARNING	
	<b>BURN HAZARD</b> Certain unit components operate at temperatures hot enough to cause burns.  Proper safety procedures must be followed, and proper protective clothing must be worn.  Failure to follow these procedures could result in minor to moderate injury.

The only definite indications that the slide is in the mid-position is if all three tubes on the suction side of the valve are hot after a few minutes of running time.

**NOTE:** If both tubes shown as hot or cool are not the same corresponding temperature, refer to figure 703, then the reversing valve is not shifting properly.

# COMPONENT TESTING

## Checking The Reversing Valve

<b>⚠ WARNING</b>	
	<b>HIGH PRESSURE HAZARD</b> Sealed Refrigeration System contains refrigerant and oil under high pressure.
	Proper safety procedures must be followed, and proper protective clothing must be worn when working with refrigerants.
	Failure to follow these procedures could result in serious injury or death.

**NOTE:** You must have normal operating pressures before the reversing valve can shift.

Check the operation of the valve by starting the system and switching the operation from “Cooling” to “Heating” and then back to “Cooling”. Do not hammer on valve.

Occasionally, the reversing valve may stick in the heating or cooling position or in the mid-position. When sluggish or stuck in the mid-position, part of the discharge gas from the compressor is directed back to the suction side, resulting in excessively high suction pressure.

Should the valve fail to shift from cooling to heating, block the air flow through the outdoor coil and allow the discharge pressure to build in the system. Then switch the system from heating to cooling.

If the valve is stuck in the heating position, block the air flow through the indoor coil and allow discharge pressure to build in the system. Then switch the system from heating to cooling.

Should the valve fail to shift in either position after increasing the discharge pressure, replace the valve.

Dented or damaged valve body or capillary tubes can prevent the main slide in the valve body from shifting. If you determine this is the problem, replace the reversing valve.

After all of the previous inspections and checks have been made and determined correct, then perform the “Touch Test” on the reversing valve.

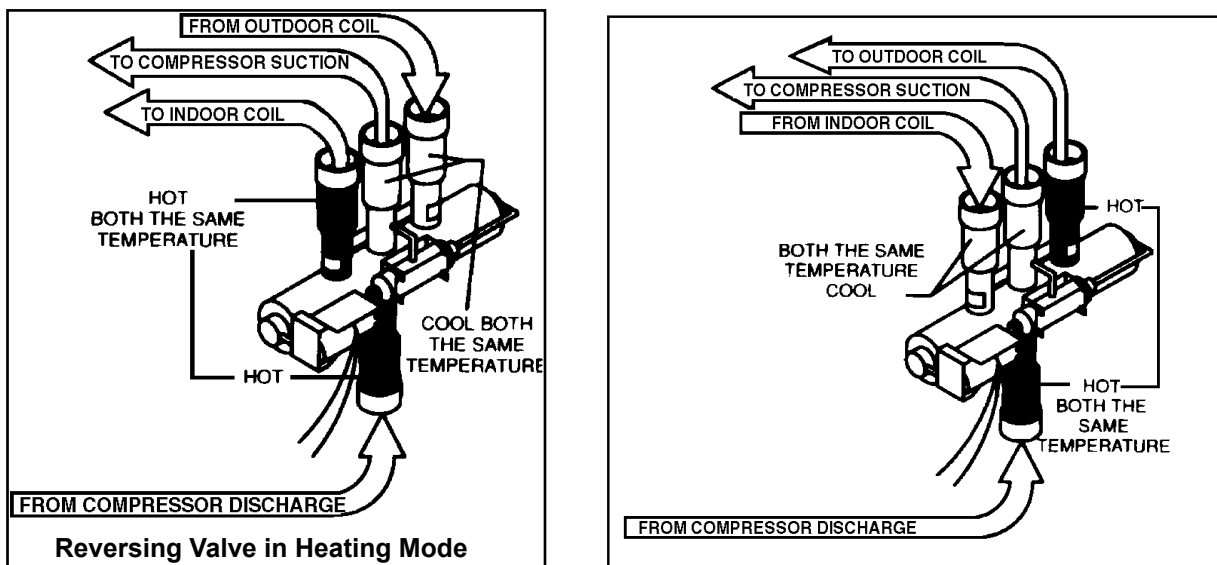



Figure 703 (Checking The Reversing Valve)

# COMPONENT TESTING

## Replace The Reversing Valve

<b>⚠ WARNING</b>	
	<b>HIGH PRESSURE HAZARD</b> Sealed Refrigeration System contains refrigerant and oil under high pressure.
	Proper safety procedures must be followed, and proper protective clothing must be worn when working with refrigerants.
	Failure to follow these procedures could result in serious injury or death.

<b>NOTICE</b>
<b>FIRE HAZARD</b> The use of a torch requires extreme care and proper judgment. Follow all safety recommended precautions and protect surrounding areas with fire proof materials. Have a fire extinguisher readily available. Failure to follow this notice could result in moderate to serious property damage.

1. Install Process Tubes. Recover refrigerant from sealed system. PROPER HANDLING OF RECOVERED REFRIGERANT ACCORDING TO EPA REGULATIONS IS REQUIRED.
2. Remove solenoid coil from reversing valve. If coil is to be reused, protect from heat while changing valve.
3. Unbrazed all lines from reversing valve.
4. Clean all excess braze from all tubing so that they will slip into fittings on new valve.
5. Remove solenoid coil from new valve.
6. Protect new valve body from heat while brazing with plastic heat sink (Thermo Trap) or wrap valve body with wet rag.
7. Fit all lines into new valve and braze lines into new valve.

<b>⚠ WARNING</b>	
	<b>EXPLOSION HAZARD</b> The use of nitrogen requires a pressure regulator. Follow all safety procedures and wear protective safety clothing etc.
	Failure to follow proper safety procedures could result in serious injury or death.

8. Pressurize sealed system with a combination of R-410A and nitrogen and check for leaks, using a suitable leak detector. Recover refrigerant per EPA guidelines.
9. Once the sealed system is leak free, install solenoid coil on new valve and charge the sealed system by weighing in the proper amount and type of refrigerant as shown on rating plate. Crimp the process tubes and solder the ends shut. Do not leave Schrader or piercing valves in the sealed system.

**NOTE: When brazing a reversing valve into the system, it is of extreme importance that the temperature of the valve does not exceed 250°F at any time.**

Wrap the reversing valve with a large rag saturated with water. "Re-wet" the rag and thoroughly cool the valve after each brazing operation of the four joints involved.

The wet rag around the reversing valve will eliminate conduction of heat to the valve body when brazing the line connection.



# COMPONENT TESTING

## Touch Test Chart : To Service Reversing Valves

NORMAL FUNCTION OF VALVE								
VALVE OPERATING CONDITION	DISCHARGE TUBE from Compressor	SUCTION TUBE	COIL	Tube to OUTSIDE COIL	LEFT Pilot	RIGHT Pilot	NOTES:	
	<b>1</b>	<b>2</b>	<b>3</b>	<b>4</b>	<b>5</b>	<b>6</b>	* TEMPERATURE OF VALVE BODY ** WARMER THAN VALVE BODY	
							<b>POSSIBLE CAUSES</b>	<b>CORRECTIONS</b>
Normal Cooling	Hot	Cool	Cool as (2)	Hot as (1)	*TVB	TVB		
Normal Heating	Hot	Cool	Hot as (1)	Cool as (2)	*TVB	TVB		
MALFUNCTION OF VALVE								
Valve will not shift from cool to heat.	Check Electrical circuit and coil						No voltage to coil.	Repair electrical circuit.
							Defective coil.	Replace coil.
	Check refrigeration charge						Low charge.	Repair leak, recharge system.
							Pressure differential too high.	Recheck system.
Valve will not shift from cool to heat.	Hot	Cool	Cool, as (2)	Hot, as (1)	*TVB	Hot	Pilot valve okay. Dirt in one bleeder hole.	Deenergize solenoid, raise head pressure, reenergize solenoid to break dirt loose. If unsuccessful, remove valve, wash out. Check on air before installing. If no movement, replace valve, add strainer to discharge tube, mount valve horizontally.
							Piston cup leak	Stop unit. After pressures equalize, restart with solenoid energized. If valve shifts, reattempt with compressor running. If still no shift, replace valve.
Valve will not shift from cool to heat.	Hot	Cool	Cool, as (2)	Hot, as (1)	*TVB	*TVB	Clogged pilot tubes.	Raise head pressure, operate solenoid to free. If still no shift, replace valve.
	Hot	Cool	Cool, as (2)	Hot, as (1)	Hot	Hot	Both ports of pilot open. (Back seat port did not close).	Raise head pressure, operate solenoid to free partially clogged port. If still no shift, replace valve.
	Warm	Cool	Cool, as (2)	Hot, as (1)	*TVB	Warm	Defective Compressor.	Replace compressor
Starts to shift but does not complete reversal.	Hot	Warm	Warm	Hot	*TVB	Hot	Not enough pressure differential at start of stroke or not enough flow to maintain pressure differential.	Check unit for correct operating pressures and charge. Raise head pressure. If no shift, use valve with smaller port.
							Body damage.	Replace valve
	Hot	Warm	Warm	Hot	Hot	Hot	Both ports of pilot open.	Raise head pressure, operate solenoid. If no shift, use valve with smaller ports.
	Hot	Hot	Hot	Hot	*TVB	Hot	Body damage.	Replace valve
							Valve hung up at mid-stroke. Pumping volume of compressor not sufficient to maintain reversal.	Raise head pressure, operate solenoid. If no shift, use valve with smaller ports.
Apparent leap in heating.	Hot	Cool	Hot, as (1)	Cool, as (2)	*TVB	*TVB	Piston needle on end of slide leaking.	Operate valve several times, then recheck. If excessive leak, replace valve.
	Hot	Cool	Hot, as (1)	Cool, as (2)	**WVB	**WVB	Pilot needle and piston needle leaking.	Operate valve several times, then recheck. If excessive leak, replace valve.
Will not shift from heat to cool.	Hot	Cool	Hot, as (1)	Cool, as (2)	*TVB	*TVB	Pressure differential too high.	Stop unit. Will reverse during equalization period. Recheck system
							Clogged pilot tube.	Raise head pressure, operate solenoid to free dirt. If still no shift, replace valve.
	Hot	Cool	Hot, as (1)	Cool, as (2)	Hot	*TVB	Dirt in bleeder hole.	Raise head pressure, operate solenoid. Remove valve and wash out. Check on air before reinstalling, if no movement, replace valve. Add strainer to discharge tube. Mount valve horizontally.
	Hot	Cool	Hot, as (1)	Cool, as (2)	Hot	*TVB	Piston cup leak.	Stop unit. After pressures equalize, restart with solenoid deenergized. If valve shifts, reattempt with compressor running. If it still will not reverse while running, replace the valve.
	Hot	Cool	Hot, as (1)	Cool, as (2)	Hot	Hot	Defective pilot.	Replace valve.
	Warm	Cool	Warm, as (1)	Cool, as (2)	Warm	*TVB	Defective compressor.	Replace compressor

Figure 704 (Touch Test Chart)

# COMPONENT TESTING

## Compressor Checks

<b>⚠ WARNING</b>	
	<b>ELECTRIC SHOCK HAZARD</b> Turn off electric power before service or installation. All electrical connections and wiring <b>MUST</b> be installed by a qualified electrician and conform to the National Electrical Code and all local codes which have jurisdiction. Failure to do so can result in personal injury or death.

<b>⚠ WARNING</b>	
	<b>BURN HAZARD</b> Proper safety procedures must be followed, and proper protective clothing must be worn when working with a torch. Failure to follow these procedures could result in moderate or serious injury.

### Locked Rotor Voltage (L.R.V.) Test

Locked rotor voltage (L.R.V.) is the actual voltage available at the compressor under a stalled condition.

### Single Phase Connections

Disconnect power from unit. Using a voltmeter, attach one lead of the meter to the run “R” terminal on the compressor and the other lead to the common “C” terminal of the compressor. Restore power to unit.

### Determine L.R.V.

Start the compressor with the volt meter attached; then stop the unit. Attempt to restart the compressor within a couple of seconds and immediately read the voltage on the meter. The compressor under these conditions will not start and will usually kick out on overload within a few seconds since the pressures in the system will not have had time to equalize. Voltage should be at or above minimum voltage of 197 VAC, as specified on the rating plate. If less than minimum, check for cause of inadequate power supply; i.e., incorrect wire size, loose electrical connections, etc.

### Amperage (L.R.A.) Test

The running amperage of the compressor is the most important of these readings. A running amperage higher than that indicated in the performance data indicates that a problem exists mechanically or electrically.

### Single Phase Running and L.R.A. Test

**NOTE:** Consult the specification and performance section for running amperage. The L.R.A. can also be found on the rating plate.

Select the proper amperage scale and clamp the meter probe around the wire to the “C” terminal of the compressor.

Turn on the unit and read the running amperage on the meter. If the compressor does not start, the reading will indicate the locked rotor amperage (L.R.A.).

### Overloads

The compressor is equipped with either an external or internal overload which senses both motor amperage and winding temperature. High motor temperature or amperage heats the overload causing it to open, breaking the common circuit within the compressor. Heat generated within the compressor shell, usually due to recycling of the motor, is slow to dissipate. It may take anywhere from a few minutes to several hours for the overload to reset.

### Checking the Overloads

#### External Overloads

With power off, remove the leads from compressor terminals. If the compressor is hot, allow the overload to cool before starting check. Using an ohmmeter, test continuity across the terminals of the external overload. If you do not have continuity; this indicates that the overload is open and must be replaced.

#### Internal Overloads

Some model compressors are equipped with an internal overload. The overload is embedded in the motor windings to sense the winding temperature and/or current draw. The overload is connected in series with the common motor terminal. Should the internal temperature and/or current draw become excessive, the contacts in the overload will open, turning off the compressor. The overload will automatically reset, but may require several hours before the heat is dissipated.

#### Checking the Internal Overload

1. With no power to unit, remove the leads from the compressor terminals.
2. Using an ohmmeter, test continuity between terminals C-S and C-R. If no continuity, the compressor overload is open and the compressor must be replaced.

# COMPONENT TESTING

## Compressor Checks

<b>⚠ WARNING</b>	
	<p><b>ELECTRIC SHOCK HAZARD</b> Turn off electric power before service or installation. Extreme care must be used, if it becomes necessary to work on equipment with power applied.</p> <p>Failure to do so could result in serious injury or death.</p>

<b>⚠ WARNING</b>	
	<p><b>HIGH PRESSURE HAZARD</b> Sealed Refrigeration System contains refrigerant and oil under high pressure.</p> <p>Proper safety procedures must be followed, and proper protective clothing must be worn when working with refrigerants.</p> <p>Failure to follow these procedures could result in serious injury or death.</p>

### Single Phase Resistance Test

Remove the leads from the compressor terminals and set the ohmmeter on the lowest scale (R x 1).

Touch the leads of the ohmmeter from terminals common to start ("C" to "S"). Next, touch the leads of the ohmmeter from terminals common to run ("C" to "R").

Add values "C" to "S" and "C" to "R" together and check resistance from start to run terminals ("S" to "R"). Resistance "S" to "R" should equal the total of "C" to "S" and "C" to "R."

In a single phase PSC compressor motor, the highest value will be from the start to the run connections ("S" to "R"). The next highest resistance is from the start to the common connections ("S" to "C"). The lowest resistance is from the run to common ("C" to "R") Before replacing a compressor, check to be sure it is defective.

### GROUND TEST

Use an ohmmeter set on its highest scale. Touch one lead to the compressor body (clean point of contact as a good connection is a must) and the other probe in turn to each compressor terminal. If a reading is obtained the compressor is grounded and must be replaced.

Check the complete electrical system to the compressor and compressor internal electrical system, check to be certain that compressor is not out on internal overload.

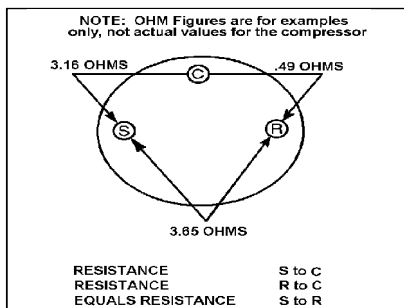

**Figure 705 (Resistance Chart)**

Complete evaluation of the system must be made whenever you suspect the compressor is defective. If the compressor has been operating for sometime, a careful examination must be made to determine why the compressor failed.

Many compressor failures are caused by the following conditions:

- 1.Improper air flow over the evaporator.
- 2.Overcharged refrigerant system causing liquid to be returned to the compressor.
- 3.Restricted refrigerant system.
- 4.Lack of lubrication.
- 5.Liquid refrigerant returning to compressor causing oil to be washed out of bearings.
- 6.Noncondensables such as air and moisture in the system. Moisture is extremely destructive to a refrigerant system.
- 7.Capacitor.

### CHECKING COMPRESSOR EFFICIENCY

The reason for compressor inefficiency is normally due to broken or damaged suction and/or discharge valves, reducing the ability of the compressor to pump refrigerant gas.

This condition can be checked as follows:

1. Install a piercing valve on the suction and discharge or liquid process tube.
2. Attach gauges to the high and low sides of the system.-
3. Start the system and run a "cooling or heating performance test." If test shows:
  - A. Below normal high side pressure
  - B. Above normal low side pressure
  - C. Low temperature difference across coil

The compressor valves are faulty - replace the compressor.

# COMPONENT TESTING

## Compressor Replacement

<b>⚠ WARNING</b>	
	<p><b>ELECTRIC SHOCK HAZARD</b> Turn off electric power before service or installation. Extreme care must be used, if it becomes necessary to work on equipment with power applied.</p> <p>Failure to do so could result in serious injury or death.</p>

<b>⚠ WARNING</b>	
	<p><b>HIGH PRESSURE HAZARD</b> Sealed Refrigeration System contains refrigerant and oil under high pressure.</p> <p>Proper safety procedures must be followed, and proper protective clothing must be worn when working with refrigerants.</p> <p>Failure to follow these procedures could result in serious injury or death.</p>

<b>⚠ WARNING</b>	
	<p><b>EXPLOSION HAZARD</b> The use of nitrogen requires a pressure regulator. Follow all safety procedures and wear protective safety clothing etc.</p> <p>Failure to follow proper safety procedures could result in serious injury or death.</p>

<b>⚠ CAUTION</b>	
	<p><b>FREEZE HAZARD</b> Proper safety procedures must be followed, and proper protective clothing must be worn when working with liquid refrigerant.</p> <p>Failure to follow these procedures could result in minor to moderate injury.</p>

1. Be certain to perform all necessary electrical and refrigeration tests to be sure the compressor is actually defective before replacing.

2. Recover all refrigerant from the system through the process tubes. **PROPER HANDLING OF RECOVERED REFRIGERANT ACCORDING TO EPA REGULATIONS IS REQUIRED.** Do not use gauge manifold for this purpose if there has been a burnout. You will contaminate your manifold and hoses. Use a Schrader valve adapter and copper tubing for burnout failures.

3. After all refrigerant has been recovered, disconnect suction and discharge lines from the compressor and remove compressor. Be certain to have both suction and discharge process tubes open to atmosphere.

4. Carefully pour a small amount of oil from the suction stub of the defective compressor into a clean container.

5. Using an acid test kit (one shot or conventional kit), test the oil for acid content according to the instructions with the kit.

6. If any evidence of a burnout is found, no matter how slight, the system will need to be cleaned up following proper procedures.

7. Install the replacement compressor.

8. Pressurize with a combination of R-410A and nitrogen and leak test all connections with an electronic or Halide leak detector. Recover refrigerant and repair any leaks found.

8a. If leak detector is unavailable remove all refrigerant from system and pressurize with nitrogen to 350 psi. Check that system holds pressure.

Repeat Step 8 to insure no more leaks are present

9. Evacuate the system with a good vacuum pump capable of a final vacuum of 200 microns or less. The system should be evacuated through both liquid line and suction line gauge ports. While the unit is being evacuated, seal all openings on the defective compressor. Compressor manufacturers will void warranties on units received not properly sealed. Do not distort the manufacturers tube connections.

10. Recharge the system with the correct amount of refrigerant. The proper refrigerant charge will be found on the unit rating plate. The use of an accurate measuring device, such as a charging cylinder, electronic scales or similar device is necessary.

# COMPONENT TESTING

## Compressor Replacement -Special Procedure in Case of Compressor Burnout

<b>⚠ WARNING</b>	
	<b>HIGH PRESSURE HAZARD</b> Sealed Refrigeration System contains refrigerant and oil under high pressure.
	Proper safety procedures must be followed, and proper protective clothing must be worn when working with refrigerants.
	Failure to follow these procedures could result in serious injury or death.

1. Recover all refrigerant and oil from the system.
2. Remove compressor, capillary tube and filter drier from the system.
3. Flush evaporator condenser and all connecting tubing with dry nitrogen or equivalent. Use approved flushing agent to remove all contamination from system. Inspect suction and discharge line for carbon deposits. Remove and clean if necessary. Ensure all acid is neutralized.
4. Reassemble the system, including new drier strainer and capillary tube.
5. Pressurize with a combination of R-410A and nitrogen and leak test all connections with an electronic or Halide leak detector. Recover refrigerant and repair any leaks found.
- 5a. If leak detector is unavailable remove all refrigerant from system and pressurize with nitrogen to 350 psi. Check that system holds pressure.

Repeat Step 5 to insure no more leaks are present

<b>⚠ WARNING</b>	
	<b>ELECTRIC SHOCK HAZARD</b> Turn off electric power before service or installation. Extreme care must be used, if it becomes necessary to work on equipment with power applied.
	Failure to do so could result in serious injury or death.

6. Evacuate the system with a good vacuum pump capable of a final vacuum of 200 microns or less. The system should be evacuated through both liquid line and suction line gauge ports. While the unit is being evacuated, seal all openings on the defective compressor. Compressor manufacturers will void warranties on units received not properly sealed. Do not distort the manufacturers tube connections.

7. Recharge the system with the correct amount of refrigerant. The proper refrigerant charge will be found on the unit rating plate. The use of an accurate measuring device, such as a charging cylinder, electronic scales or similar device is necessary.

### ROTARY AND SCROLL COMPRESSOR SPECIAL TROUBLESHOOTING AND SERVICE

Troubleshooting and servicing rotary compressors is basically the same as on the reciprocating compressor with only one main exception:

**NEVER**, under any circumstances, liquid charge a rotary-compressor through the **LOW** side. Doing so would cause permanent damage to the new compressor. Use a charging adapter.

<b>⚠ WARNING</b>	
	<b>EXPLOSION HAZARD</b> The use of nitrogen requires a pressure regulator. Follow all safety procedures and wear protective safety clothing etc.
	Failure to follow proper safety procedures could result in serious injury or death.

# COMPONENTS TESTING

## Fan Motor

A single phase permanent split capacitor motor is used to drive the evaporator blower and condenser fan. A self-resetting overload is located inside the motor to protect against high temperature and high amperage conditions.

<b>⚠ WARNING</b>	
	<p><b>ELECTRIC SHOCK HAZARD</b> Turn off electric power before service or installation. Extreme care must be used, if it becomes necessary to work on equipment with power applied.</p> <p>Failure to do so could result in serious injury or death.</p>

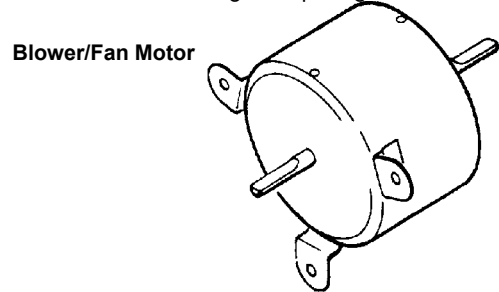

**Figure 706 (Blower)**

### Blower / Fan Motor Test

1. Determine that capacitor is serviceable.
2. Disconnect fan motor wires from fan speed switch or system switch.
3. Apply "live" test cord probes on black wire and common terminal of capacitor. Motor should run at high speed.
4. Apply "live" test cord probes on red wire and common terminal of capacitor. Motor should run at low speed.
5. Apply "live" test cord probes on each of the remaining wires from the speed switch or system switch to test intermediate speeds. If the control is in the "MoneySaver" mode and the thermostat calls for cooling, the fan will start - then stop after approximately 2 minutes; then the fan and compressor will start together approximately 2 minutes later.

## Capacitors

<b>⚠ WARNING</b>	
	<p><b>ELECTRIC SHOCK HAZARD</b> Turn off electric power before service or installation. Extreme care must be used, if it becomes necessary to work on equipment with power applied.</p> <p>Failure to do so could result in serious injury or death.</p>

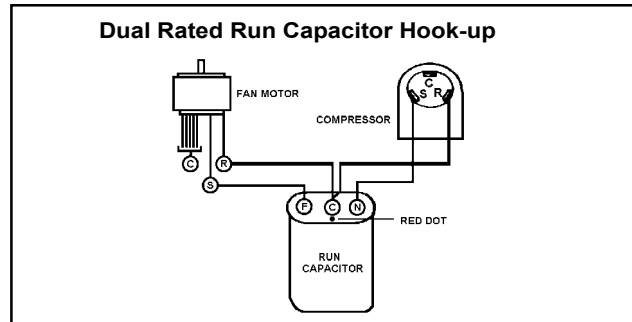

**Figure 707 Dual Rated Capacitor Hook-up**

Many motor capacitors are internally fused. Shorting the terminals will blow the fuse, ruining the capacitor. A 20,000 ohm 2 watt resistor can be used to discharge capacitors safely. Remove wires from capacitor and place resistor across terminals. When checking a dual capacitor with a capacitor analyzer or ohmmeter, both sides must be tested.

### Capacitor Check with Capacitor Analyzer

The capacitor analyzer will show whether the capacitor is "open" or "shorted." It will tell whether the capacitor is within its micro farads rating and it will show whether the capacitor is operating at the proper power-factor percentage. The instrument will automatically discharge the capacitor when the test switch is released.

### Capacitor Connections

The starting winding of a motor can be damaged by a shorted and grounded running capacitor. This damage usually can be avoided by proper connection of the running capacitor terminals.

From the supply line on a typical 230 volt circuit, a 115 volt potential exists from the "R" terminal to ground through a possible short in the capacitor. However, from the "S" or start terminal, a much higher potential, possibly as high as 400 volts, exists because of the counter EMF generated in the start winding. Therefore, the possibility of capacitor failure is much greater when the identified terminal is connected to the "S" or start terminal. The identified terminal should always be connected to the supply line, or "R" terminal, never to the "S" terminal.

When connected properly, a shorted or grounded running capacitor will result in a direct short to ground from the "R" terminal and will blow the line fuse. The motor protector will protect the main winding from excessive temperature.

# TROUBLESHOOTING

ROOM AIR CONDITIONER UNIT PERFORMANCE TEST DATA SHEET		
JOB NAME _____	TECH'S NAME _____	
DATE _____	MODEL# _____	SERIAL # _____
<b>CHECK THE INSTALLATION</b>	ACCEPTABLE YES	NOT ACCEPTABLE NO
IS A CHASIS GASKET INSTALLED?	_____	_____
IS THE FRESH / EXHAUST AIR VENT OPEN?	_____	_____
IS A FRIEDRICH SLEEVE INSTALLED?	_____	_____
IS A FRIEDRICH OUTDOOR GRILLE INSTALLED?	_____	_____
IS MAINTENANCE BEING PERFORMED?	_____	_____
<b>ELECTRICAL</b>		
LINE VOLTAGE (STATIC)	_____	VOLTS
START UP VOLTAGE	_____	VOLTS
AMPERAGE DRAW (COOL)	_____	AMPS
AMPERAGE DRAW (HEAT)	_____	AMPS
<b>COMPRESSOR</b>		
LOCKED ROTOR AMPS	_____	AMPS
RUNNING AMPERAGE DRAW	_____	AMPS
<b>INDOOR CONDITIONS</b>		
INDOOR AMBIENT TEMPERATURE	_____	F
RELATIVE HUMIDITY (RH) INDOOR	_____	%
DISCHARGE AIR TEMPERATURE (INDOOR)(COOL)	_____	F
DISCHARGE AIR TEMPERATURE (INDOOR)(HEAT)	_____	F
RETURN AIR TEMPERATURE (INDOOR)(COOL)	_____	F
RETURN AIR TEMPERATURE (INDOOR) (HEAT)	_____	F
<b>OUTDOOR TEMPERATURE</b>		
OUTDOOR AMBIENT TEMPERATURE	_____	F
RH OUTDOOR RELATIVE HUMIDITY	_____	%
DISCHARGE AIR TEMPERATURE (OUTDOOR)(COOL)	_____	F
DISCHARGE AIR TEMPERATURE (OUTDOOR)(HEAT)	_____	F
INTAKE AIR TEMPERATURE (OUTDOOR)(COOL)	_____	F
INTAKE AIR TEMPERATURE (OUTDOOR)(HEAT)	_____	F
<b>COOLING OR HEATING AREA</b>		
AREA W _____ * L _____ = FEET SQUARED		
FOR A GENERAL GUIDE REFER TO SIZING GUIDE TO THE RIGHT		
FOR EXACT LOAD CALCULATIONS CONSULT MANUAL J OR M.		

Figure 713 (Test Data Sheet)

## COOLING SIZING GUIDE

AREA TO BE CONDITIONED IN SQ. FT.	APPROXIMATE COOLING BTU REQUIRED
100 - 150	5000
150 - 250	6000
250 - 300	7000
300 - 350	8000
350 - 400	9000
400 - 450	10000
450 - 550	12000
550 - 700	14000
700 - 1000	18000
1000 - 1200	21000
1200 - 1400	23000
1400 - 1500	24000
1500 - 2000	30000
2000 - 2500	34000

Guide based on normal room insulation, average number of sun exposed windows and two person occupancy.

1. If heavily shaded, reduce cooling Btus required by 10%
2. If very sunny, increase cooling Btus required by 10%
3. Add 500 Btus per person over 2 people
4. Add 4,000 Btus if the area is a kitchen

Figure 714 (Cooling Sizing Guide)

---

# TROUBLESHOOTING

## Product Does Not Operate At All

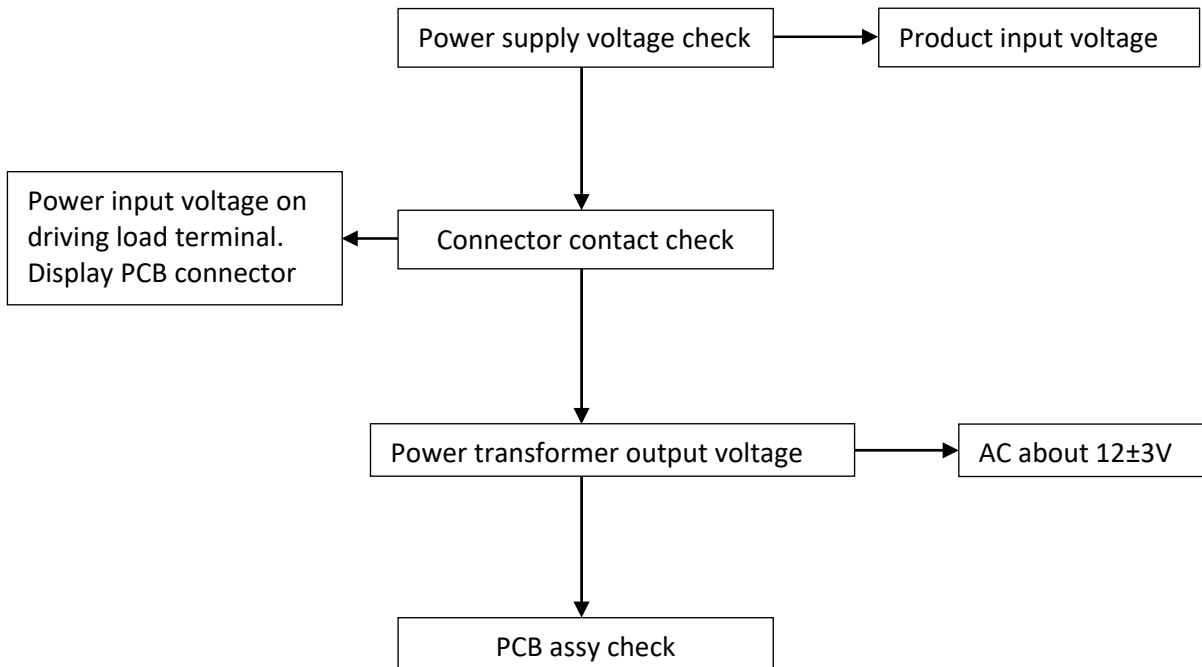

Figure 715



# TROUBLESHOOTING

## Indoor Fan Does Not Operate At All

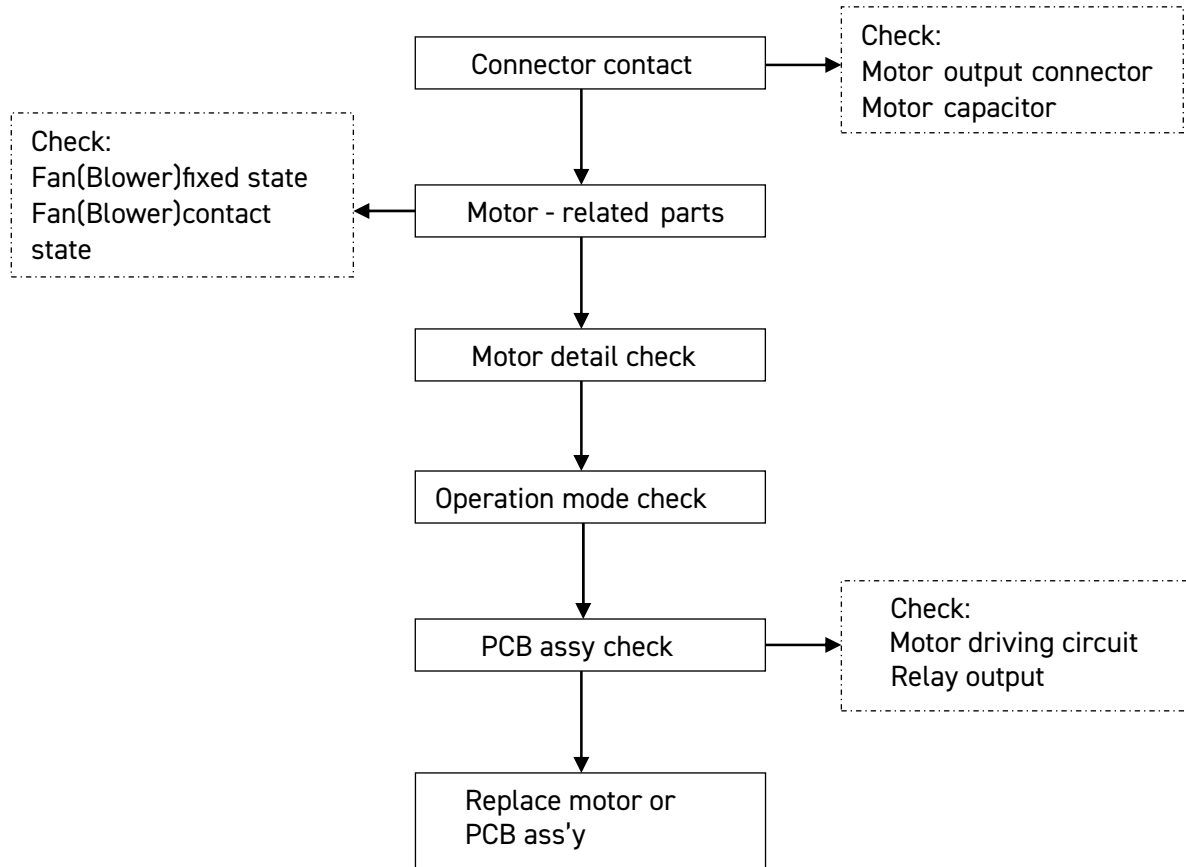

Figure 716

# TROUBLESHOOTING

## Compressor Or Outdoor Fan Does Not Operate At All

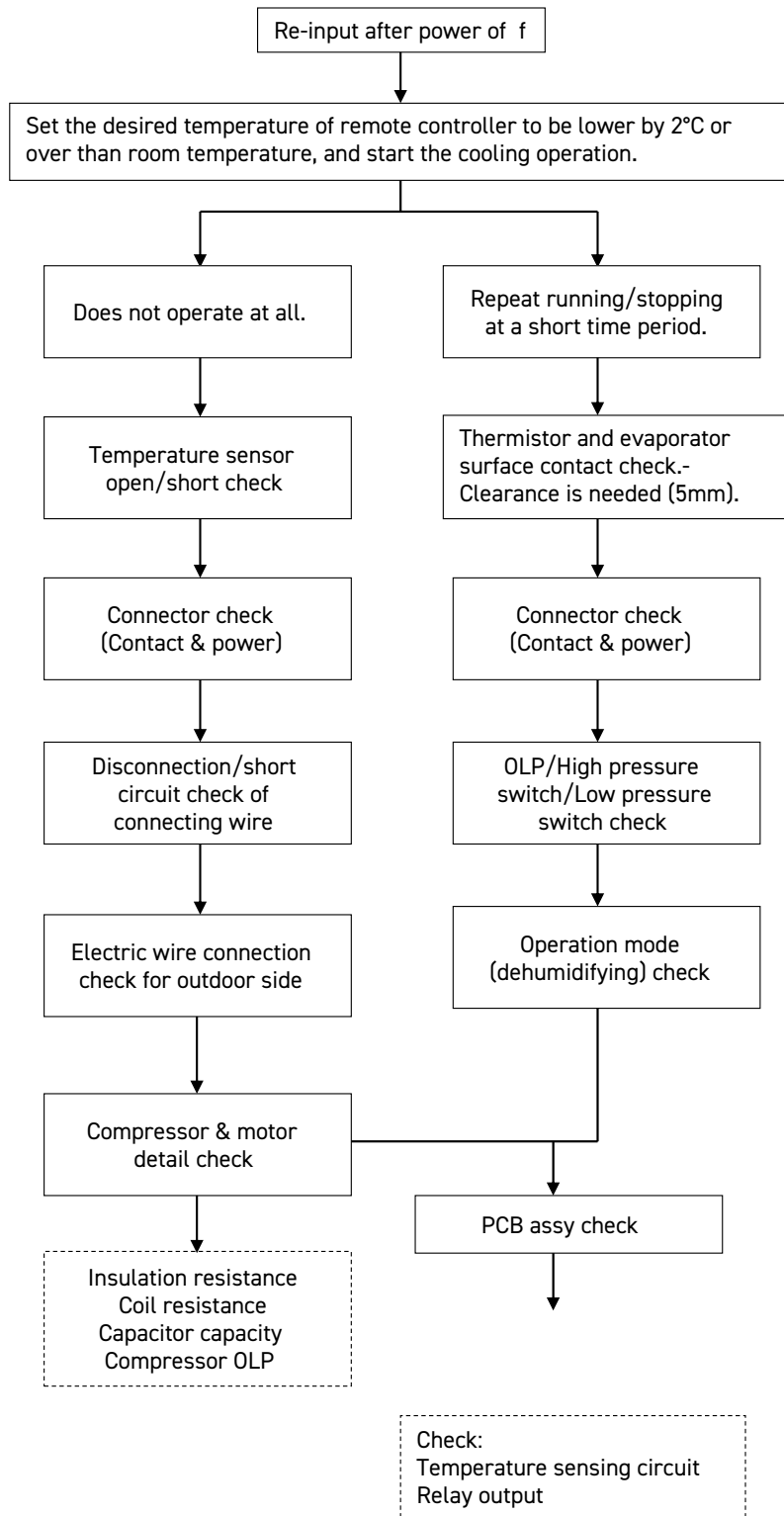

Figure 716

---

# TROUBLESHOOTING

Display E1 or E2

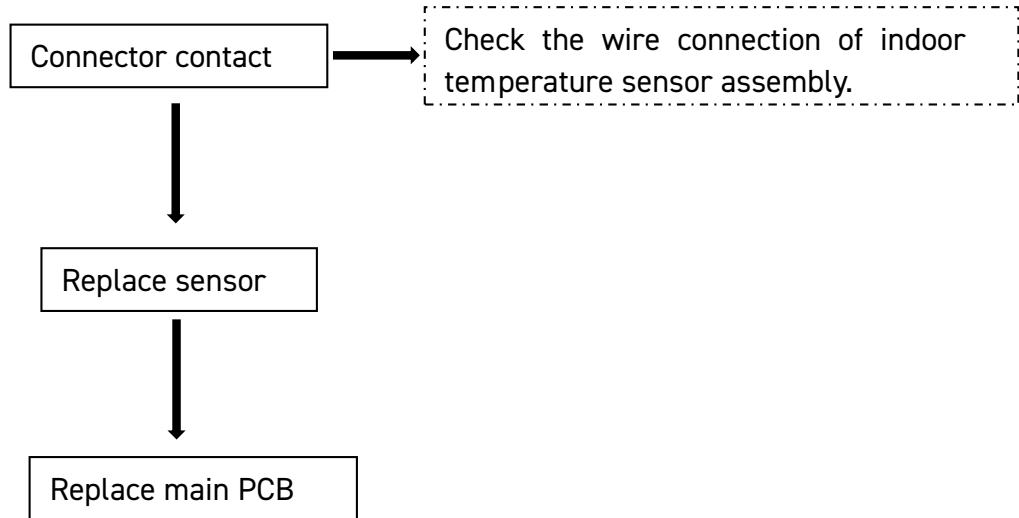

Figure 716

# WIRING DIAGRAMS

Chill Premier CCF

Models: CCF05A10A CCF06A10A CCF08A10A

CCF10A10A CCF12A10A

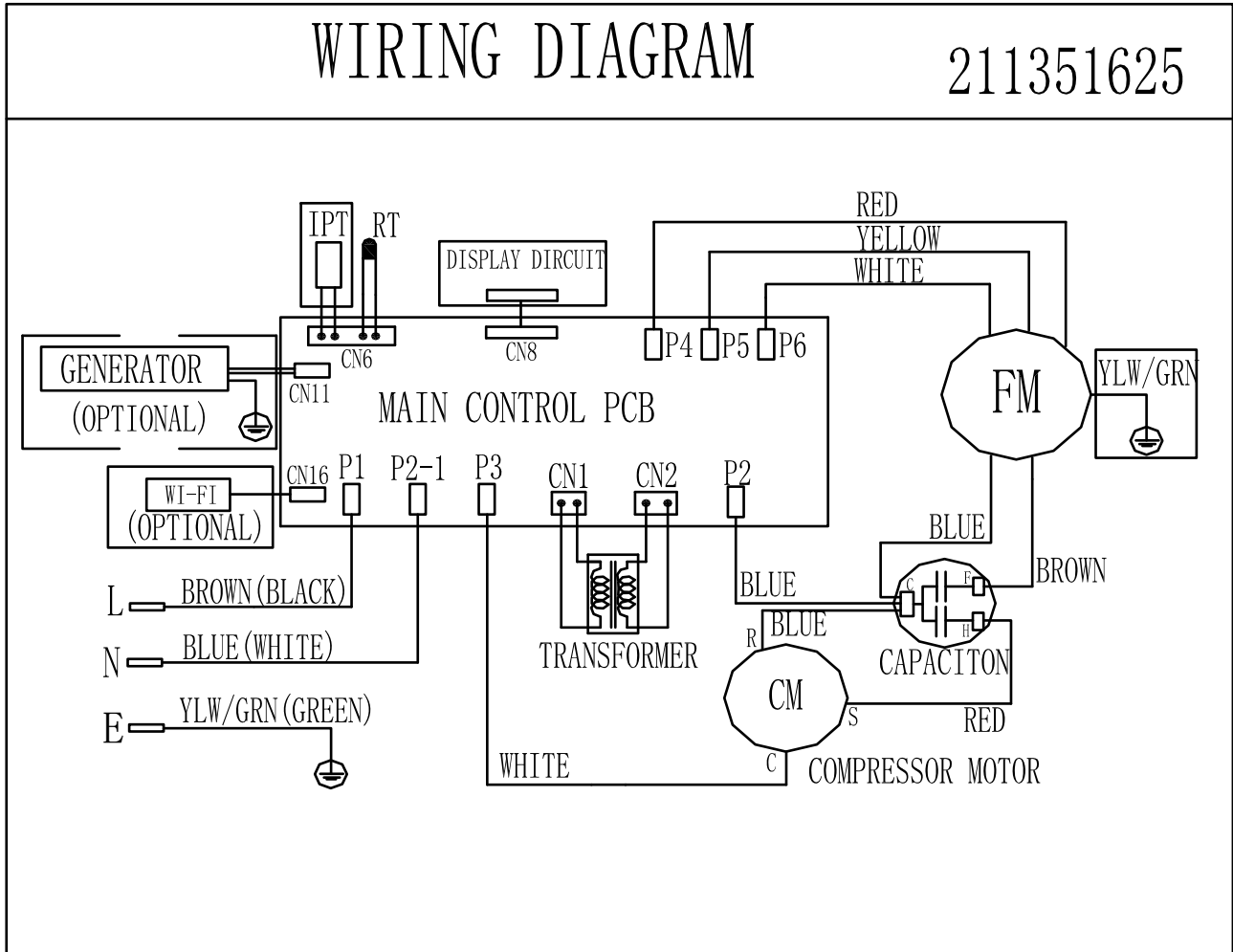

Figure 801

# WIRING DIAGRAMS

Chill Premier CCW

Models: CCW06B10A . CCW24B30A

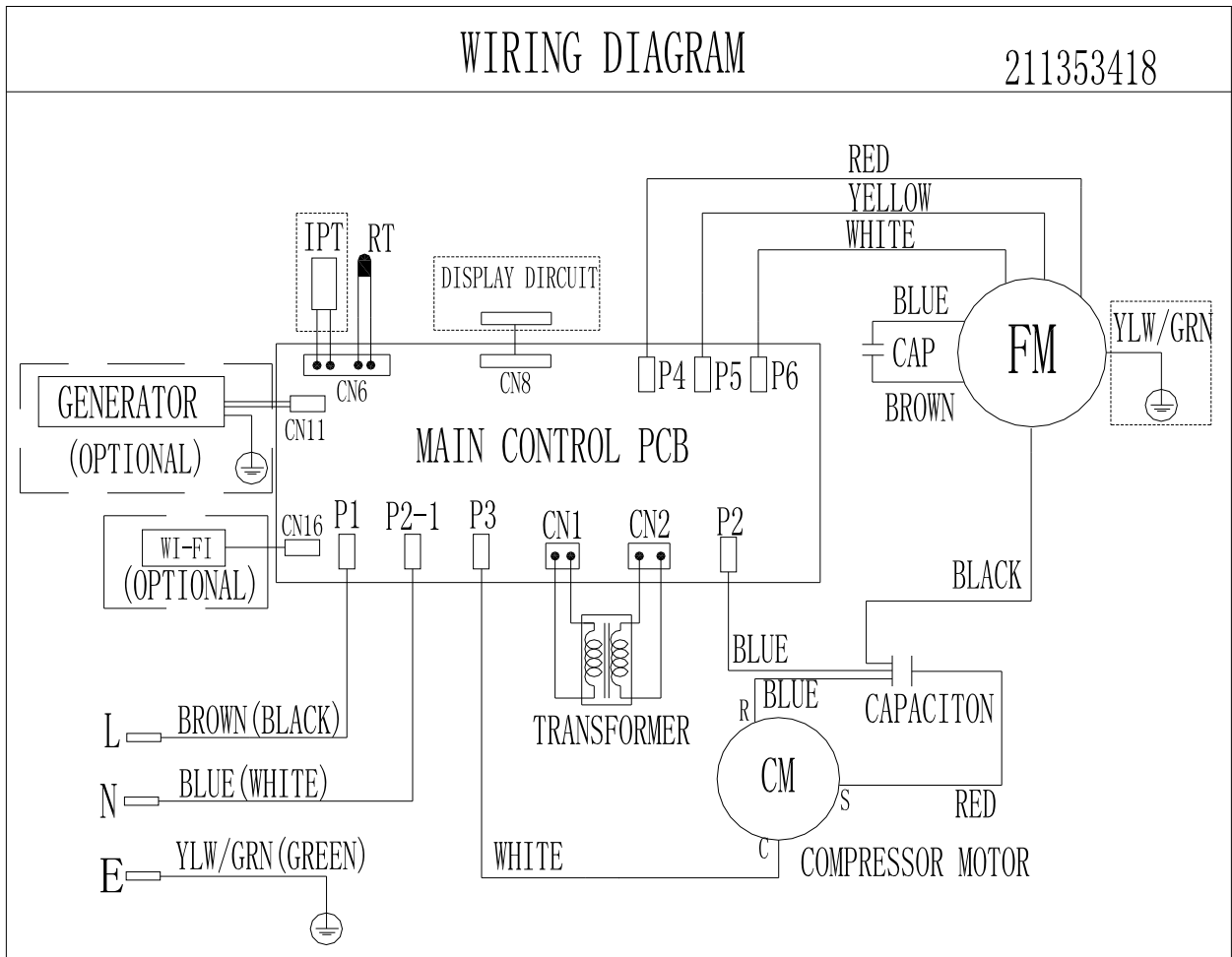

Figure 802

# WIRING DIAGRAMS

Chill Premier CCW  
CCW08B10A

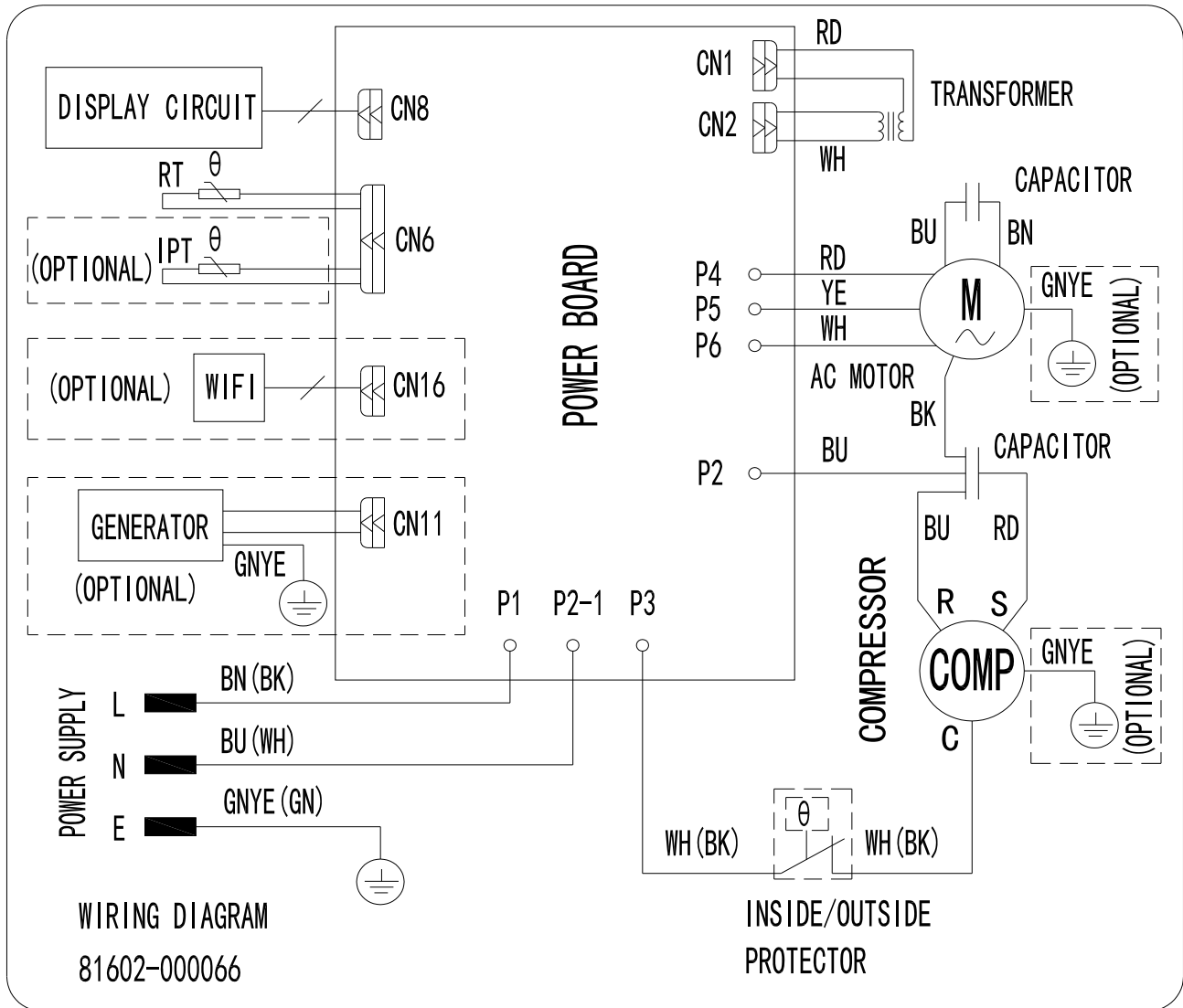

Figure 803

# WIRING DIAGRAMS

Chill Premier

CCW10B10A, CCW12B10A, CCW15B10A, CCW18B30A

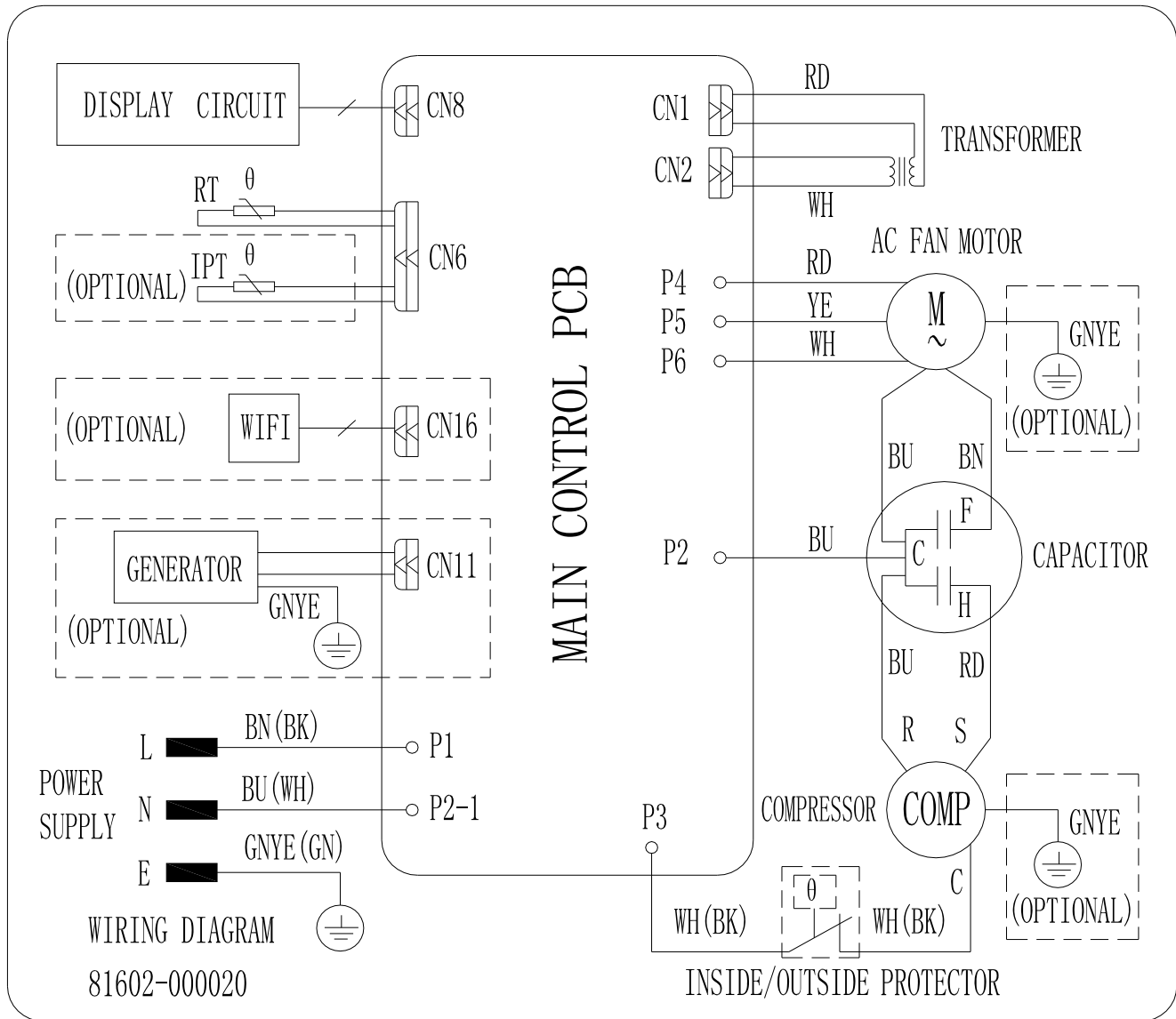

Figure 804

# WIRING DIAGRAMS

Chill Premier CEW  
CEW08B11A

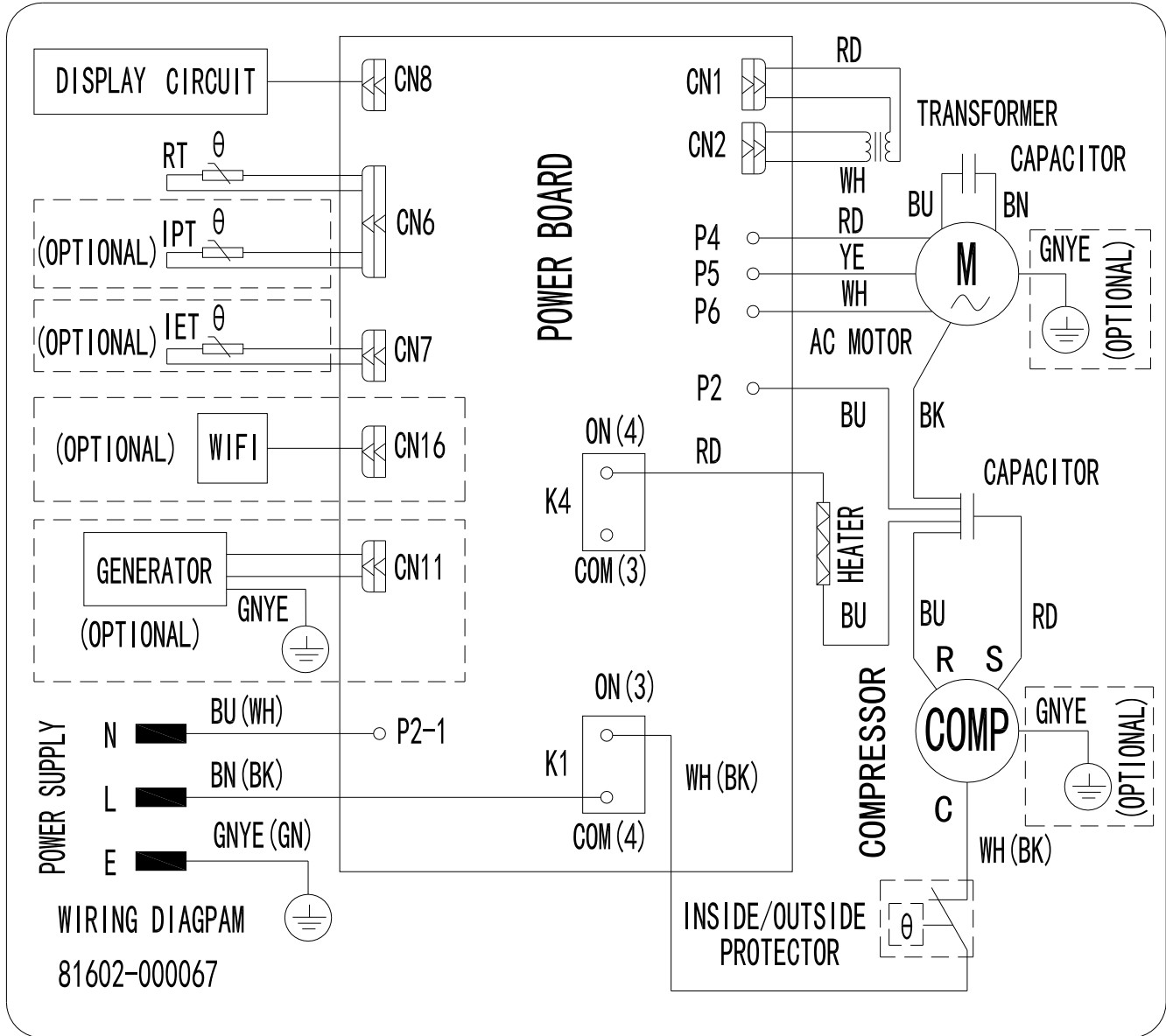

Figure 805



# WIRING DIAGRAMS

Chill Premier CEW

CEW12B33A, CEW18B33A

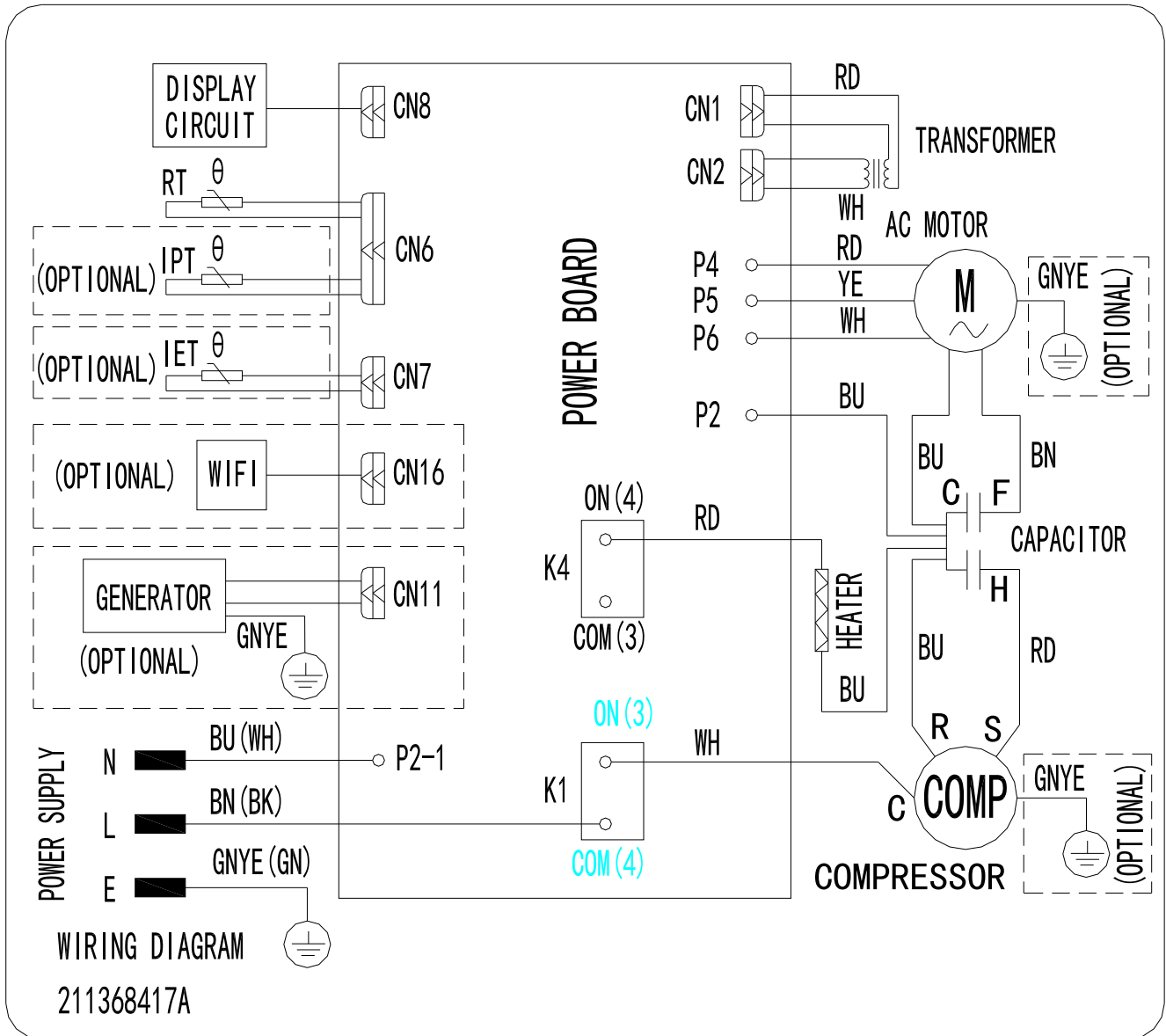

Figure 806

# WIRING DIAGRAMS

Chill Premier CEW  
CEW24B33A

## WIRING DIAGRAM

211366159

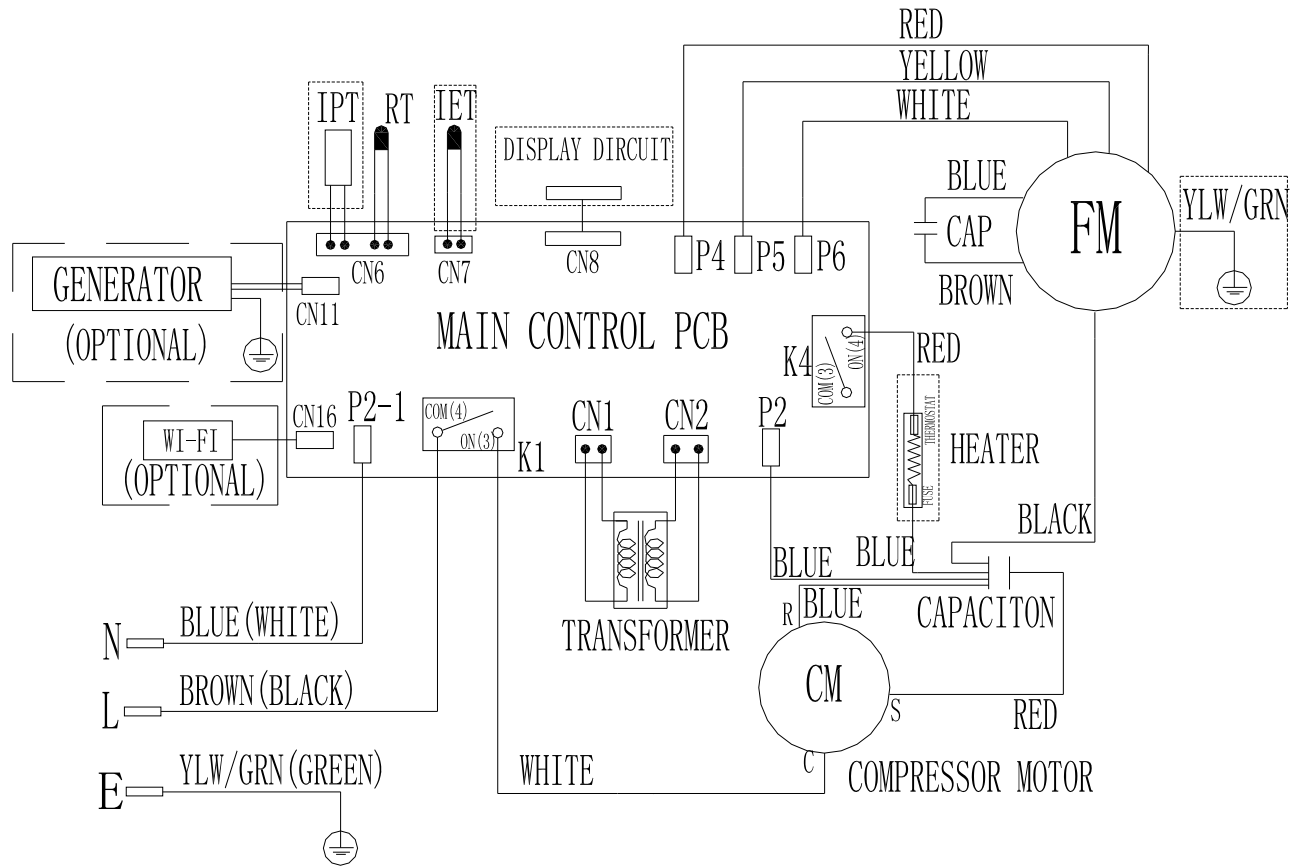

Figure 807

# WIRING DIAGRAMS

Unifit

UCT08A10A, UCT10A10A, UCT12A10A, UCT10A30A, UCT12A30A, UCT14A30A

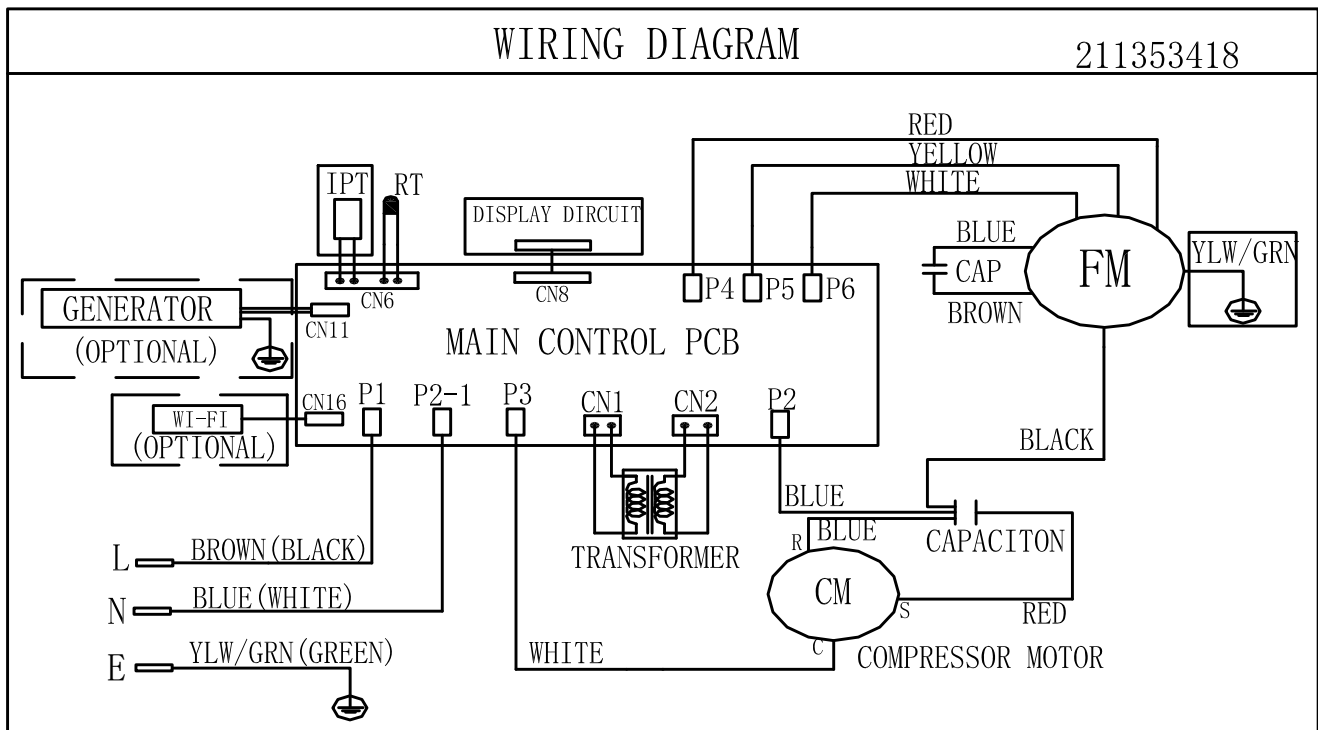

Figure 808

# WIRING DIAGRAMS

Unifit

UET10A33A, UET12A33A, UET14A33A, UET08A11A

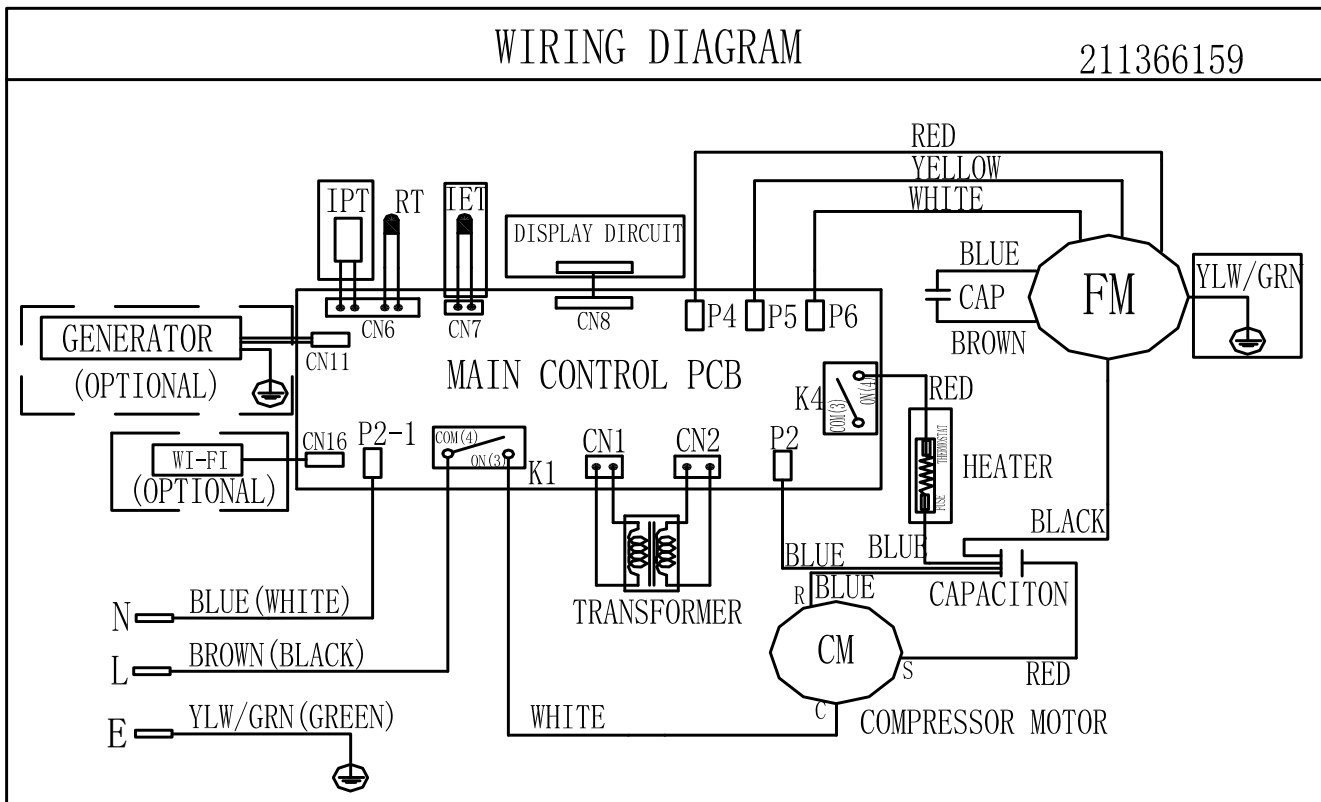
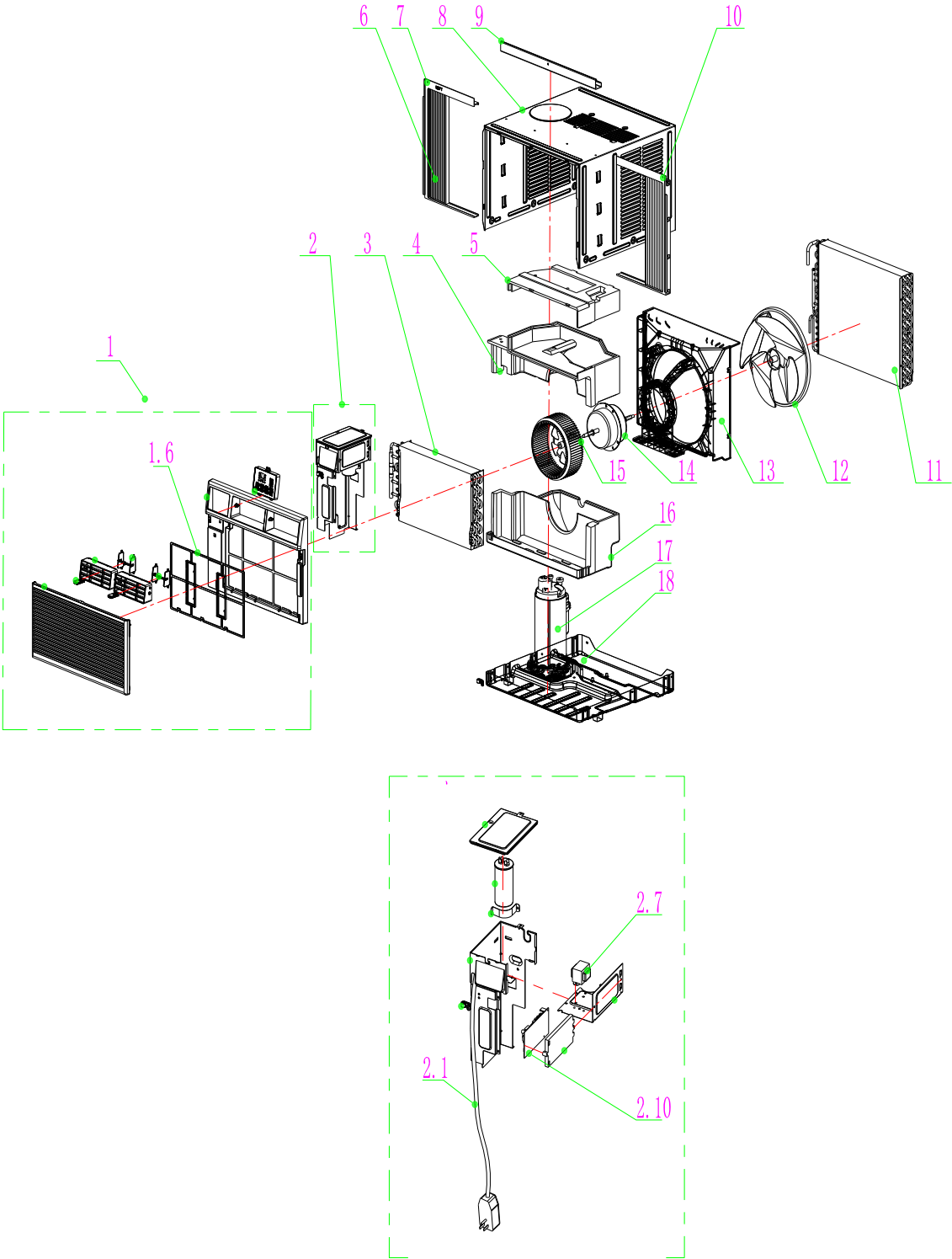

Figure 809

# PARTS CATALOG

Chill Premier Models: CCW06B10A CCW08B10A CCW10B10A CCW12B10A

Figure 901



# PARTS CATALOG

Figure 901

Chill Premier Models: CCW06B10A CCW08B10A CCW10B10A CCW12B10A

ITEM	PART NUMBER	PART DESCRIPTION	USED ON MODEL	QTY
1	68000163	41106-003745_UI - Front Panel Assembly	CCW06B10A, CCW08B10A,CCW10B10A	1
1A	68000264	41106-003738_UI - Front Panel Assembly	CCW12B10A	1
1.6	68000175	41507-000136 - Air Filter	CCW06B10A, CCW08B10A, CCW10B10A, CCW12B10A	1
2	68000181	41505-000230 - Electrical Box Assembly	CCW06B10A, CCW08B10A, CCW10B10A, CCW12B10A	1
2.1	68000183	22007-000068_UI - Power Supply Cord	CCW06B10A, CCW08B10A	1
2.1A	68000256	22007-000069 - Power Supply Cord	CCW10B10A, CCW12B10A	1
2.7	68000197	10502-100032_UI - Transformer	CCW06B10A, CCW08B10A, CCW10B10A , CCW12B10A	1
2.10	68000203	31502-000014_UI - Main pcb	CCW06B10A, CCW08B10A, CCW10B10A, CCW12B10A	1
3	68000205	92011-005038 - Evaporator	CCW06B10A	1
3A	68000245	92011-004873 - Evaporator	CCW08B10A	1
3B	68000259	92011-005089 - Evaporator	CCW10B10A	1
3C	68000267	92011-004459 - Evaporator	CCW12B10A	1
4	68000207	41504-000140_UI - Middle Vortex Shell	CCW06B10A, CCW08B10A, CCW10B10A , CCW12B10A	1
5	68000209	41504-000134_UI - Up Vortex Shell	CCW06B10A, CCW08B10A, CCW10B10A, CCW12B10A	1
6	68000211	41509-000049 - Adjustable shade	CCW06B10A, CCW08B10A, CCW10B10A, CCW12B10A	1
7	68000221	41509-000053 - left Adjustable shade rail	CCW06B10A, CCW08B10A, CCW10B10A, CCW12B10A	1
8	68000222	41508-000016_UI - Cabinet	CCW06B10A, CCW08B10A, CCW10B10A, CCW12B10A	1
9	68000223	41509-000023 - Up Adjustable shade rail	CCW06B10A, CCW08B10A, CCW10B10A, CCW12B10A	1
10	68000224	41509-000051 - Right Adjustable shade rail	CCW06B10A, CCW08B10A, CCW10B10A, CCW12B10A	1
11	68000205	92011-005038 - Condenser	CCW08B10A, CCW10B10A	1
11A	68000260	92011-005088 - Condenser	CCW10B10A	1
11B	68000268	92011-004641 - Condenser	CCW12B10A	1
12	68000225	41503-000007_UI - Propeller Fan	CCW06B10A, CCW08B10A, CCW10B10A, CCW12B10A	1
13	68000226	41504-000192_UI - Back Surround Plate	CCW06B10A, CCW12B10A	1
13A	68000250	41504-000193 - Back Surround Plate	CCW08B10A, CCW10B10A	1
14	68000227	22001-000427_UI - Fan Motor	CCW06B10A, CCW08B10A	1
14A	68000261	22001-000394 - Fan Motor	CCW10B10A, CCW12B10A	1
15	68000228	41503-000010_UI - Centrifugal Fan	CCW06B10A, CCW08B10A, CCW10B10A, CCW12B10A	1
16	68000229	41504-000173_UI - Water drainage pan	CCW06B10A, CCW08B10A, CCW10B10A, CCW12B10A	1

# PARTS CATALOG

Chill Premier Models: CCW06B10A CCW08B10A CCW10B10A CCW12B10A

Figure 901

ITEM	PART NUMBER	PART DESCRIPTION	USED ON MODEL	QTY
17	68000230	92014-000599 - Compressor	CCW06B10A	1
17A	68000254	92014-000259 - Compressor	CCW08B10A	1
17B	68000262	92014-000305 - Compressor	CCW10B10A	1
17C	68000270	92014-000262 - Compressor	CCW12B10A	1
18	68000231	41502-000042 - Base	CCW06B10A, CCW08B10A, CCW10B10A, CCW12B10A	1
-19	68000232	10104-100026 - Sensor	CCW06B10A, CCW08B10A, CCW10B10A, CCW12B10A	1
-20	68000233	31502-000025 - Display PCB	CCW06B10A, CCW08B10A, CCW10B10A, CCW12B10A	1
-24	68000237	32001-000129 - WIFI Assembly	CCW06B10A, CCW08B10A, CCW10B10A, CCW12B10A	1
1-ITEMS ARE NON- ILLUSTRATED				
*1ITEMS ARE NON-STOCKED, WILL NORMALLY REQUIRE 2-3 WEEKS LEAD TIME				

# PARTS CATALOG

Chill Premier Models: CCW15B10A CCW18B30A

Figure 902

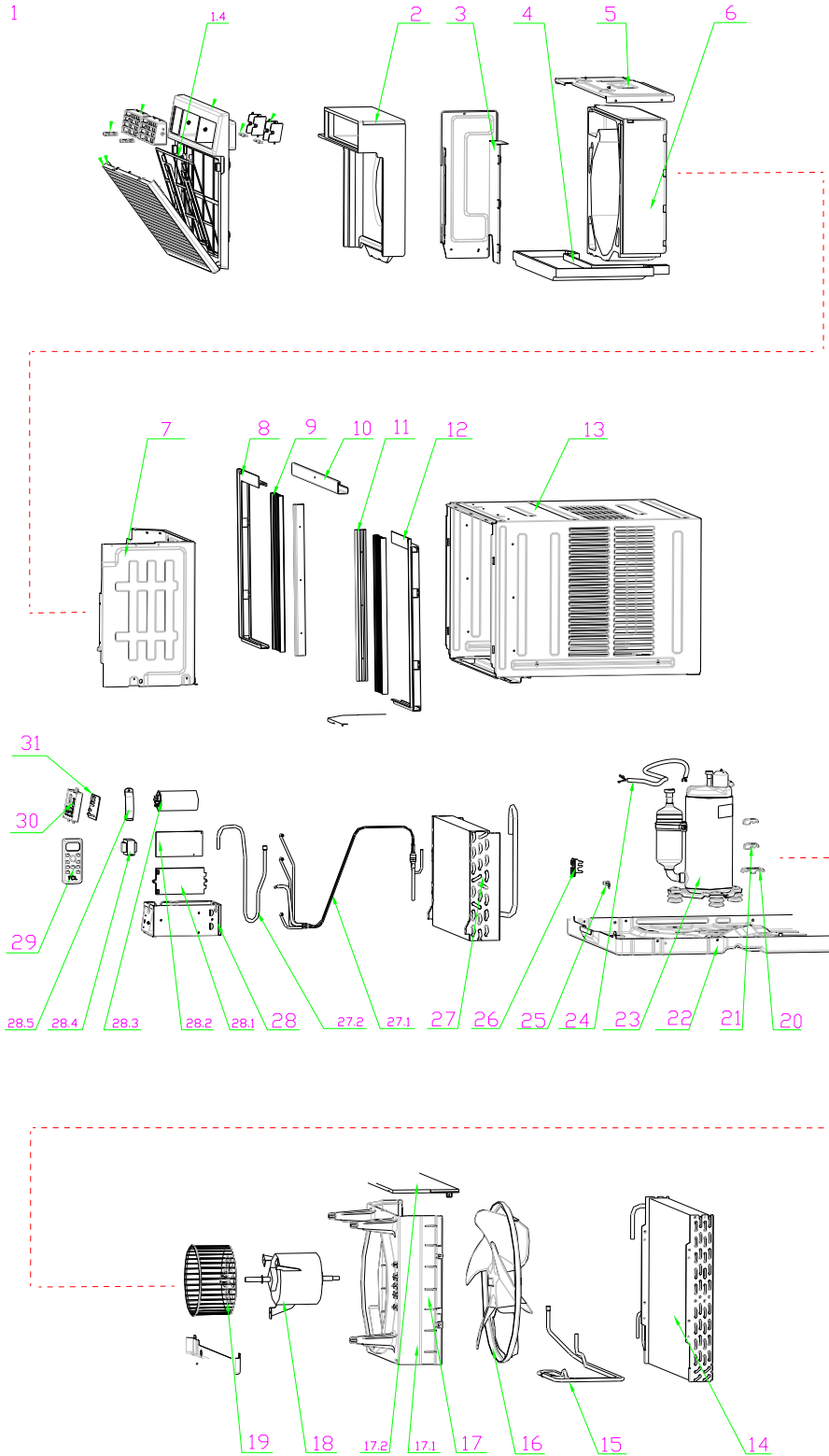



# PARTS CATALOG

Chill Premier Models: CCW15B10A CCW18B30A

Figure 902

ITEM	PART NUMBER	PART DESCRIPTION	USED ON MODEL	QTY
1	68000273	41106-003518_UW - Front Panel Assembly	CCW15B10A, CCW18B30A	1
1.4	68000276	42008-000095 - Air Filter	CCW15B10A, CCW18B30A	1
2	68000280	41504-000148_UW - Front Vortex Shell	CCW15B10A, CCW18B30A	1
3	68000281	41214-001067_UW - Electrical Box Cover supporter	CCW15B10A, CCW18B30A	1
4	68000282	41504-000099 - Water drainage pan	CCW15B10A, CCW18B30A	1
5	68000283	41504-000055 - Top plate	CCW15B10A, CCW18B30A	1
6	68000284	41504-000142_UW - Back Vortex Shell	CCW15B10A, CCW18B30A	1
7	68000285	41504-000038 - Partition plate	CCW15B10A, CCW18B30A	1
8	68000286	41509-000040 - left Adjustable shade rail	CCW15B10A, CCW18B30A	1
9	68000287	41509-000014 - Adjustable shade	CCW15B10A, CCW18B30A	1
10	68000288	41509-000026 - Up Adjustable shade rail	CCW15B10A, CCW18B30A	1
11	68000289	41214-000913 - Adjustable shade rod	CCW15B10A, CCW18B30A	1
12	68000290	41509-000030 - Right Adjustable shade rail	CCW15B10A, CCW18B30A	1
13	68000291	41608-000012_UW - Cabinet	CCW15B10A, CCW18B30A	1
14	68000292	92011-000770 - Condenser	CCW15B10A, CCW18B30A	1
15	68000293	92007-003562 - cold tube	CCW15B10A, CCW18B30A	1
16	68000294	41503-000008_UW - Propeller Fan	CCW15B10A, CCW18B30A	1
17	68000295	41706-000002_UW - Back Surround Plate Assembly	CCW15B10A, CCW18B30A	1
18	68000320	22001-000165_UW - Fan Motor	CCW15B10A, CCW18B30A	1
19	68000299	41503-000009_UW - Centrifugal Fan	CCW15B10A, CCW18B30A	1
20	68000300	41214-000857 - Pipe Cover (four-way)	CCW15B10A, CCW18B30A	1
21	68000301	41214-000856 - Pipe Cover (two-way)	CCW15B10A, CCW18B30A	1
22	68000302	41602-000016_UW - Base	CCW15B10A, CCW18B30A	1
23	68000303	92014-000260 - Compressor	CCW15B10A	1
23A	68000321	92014-000275 - Compressor	CCW18B30A	1
24	68000304	22007-000280_UW - Compressor wire	CCW15B10A, CCW18B30A	1
25	68000257	42001-000057 - Cable Clamp	CCW15B10A, CCW18B30A	1
25A	68000322	42001-000058 - Cable Clamp	CCW15B10A, CCW18B30A	1
26	68000305	41605-000011 - Sensor Holder	CCW15B10A, CCW18B30A	1

# PARTS CATALOG

Chill Premier Models: CCW15B10A CCW18B30A

Figure 902

ITEM	PART NUMBER	PART DESCRIPTION	USED ON MODEL	QTY
27	68000306	92011-003343 - Evaporator	CCW15B10A	1
27A	68000323	92011-003349 - Evaporator	CCW18B30A	1
27.1	68000307	92007-001542 - Capillary Assembly	CCW15B10A	1
27.1A	68000324	92007-001525 - Capillary Assembly	CCW18B30A	1
27.2	68000308	92006-000181 - Discharge Pipe	CCW15B10A	1
27.2A	68000325	92006-000180 - Discharge Pipe	CCW18B30A	1
28	68000309	41505-000233 - Electrical Box	CCW15B10A, CCW18B30A	1
28.1	68000310	41214-000877_UW - Main pcb supporter	CCW15B10A, CCW18B30A	1
28.2	68000311	11201-100000 - Main pcb	CCW15B10A	1
28.2A	68000326	31502-000006_UW - Main pcb	CCW18B30A	1
28.3	68000312	10303-100043_UW - Capacitor	CCW15B10A	1
28.3A	68000327	10303-100040_UW - Capacitor	CCW18B30A	1
28.4	68000313	10502-100032_UW - Transformer	CCW15B10A	1
28.4A	68000328	10502-100034_UW - Transformer	CCW18B30A	1
28.5	68000189	42001-000027 - Capacitor Strip	CCW15B10A	1
28.5A	68000329	42001-000025 - Capacitor Strip	CCW18B30A	1
29	68000314	22013-000936 - Remote Controller	CCW15B10A, CCW18B30A	1
30	68000179	41507-000031 - Control Box panel	CCW15B10A, CCW18B30A	1
31	68000315	31502-000027 - Display PCB	CCW15B10A, CCW18B30A	1
-35	68000319	22007-000069_UW - Power Supply Cord	CCW15B10A	1
-35A	68000331	22007-000067_UW - Power Supply Cord	CCW18B30A	1
-36	68000237	32001-000129 - WIFI Assembly	CCW15B10A, CCW18B30A	1
-ITEMS ARE NON- ILLUSTRATED				
*ITEMS ARE NON-STOCKED, WILL NORMALLY REQUIRE 2-3 WEEKS LEAD TIME				

# PARTS CATALOG

Chill Premier Models: CCW24B30A

Figure 903

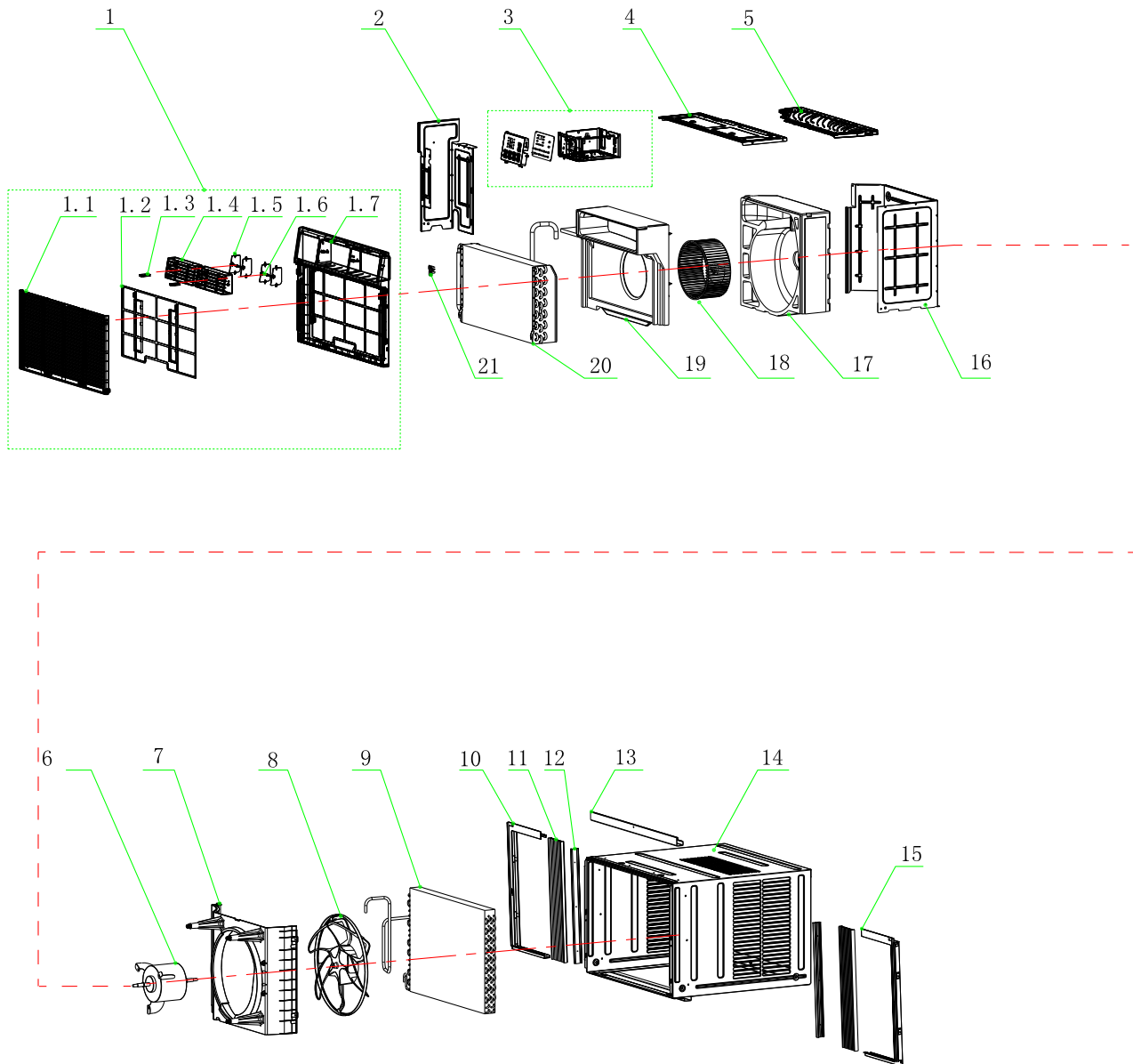

# PARTS CATALOG

Chill Premier Models: CCW24B30A

Figure 903

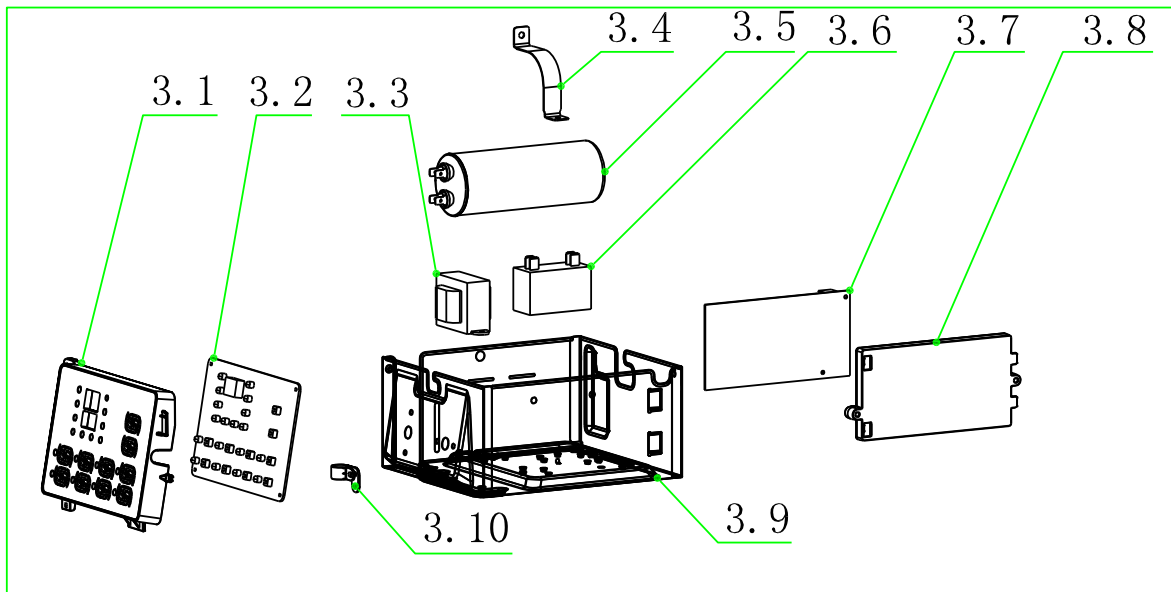
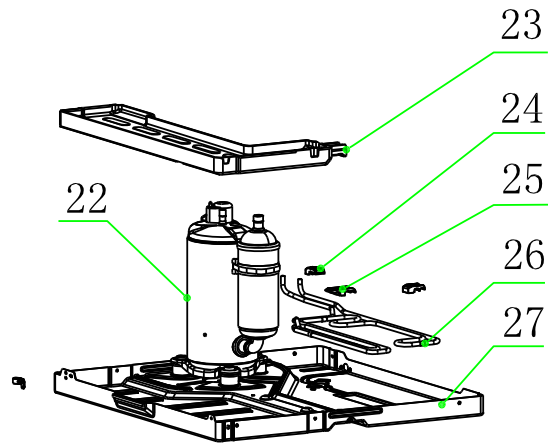

# PARTS CATALOG

Chill Premier Models: CCW24B30A

Figure 903

ITEM	PART NUMBER	PART DESCRIPTION	USED ON MODEL	QTY
1	68000332	41106-003519_UW - Front Panel Assembly	CCW24B30A	1
1.2	68000334	41507-000137 - Air Filter	CCW24B30A	1
2	68000339	41205-000164 - Left Supporter	CCW24B30A	1
3	68000340	41505-000229 - Electrical Box Assembly	CCW24B30A	1
3.1	68000341	41507-000033 - Control Box panel	CCW24B30A	1
3.2	68000342	31502-000026 - Display PCB	CCW24B30A	1
3.3	68000328	10502-100034_UW - Transformer	CCW24B30A	1
3.4	68000189	42001-000027 - Capacitor Strip	CCW24B30A	1
3.5	68000343	22003-000006_UW - Compressor Capacitor	CCW24B30A	1
3.6	68000344	10303-100018_UW - Fan Motor Capacitor	CCW24B30A	1
3.7	68000326	31502-000006_UW - Main pcb	CCW24B30A	1
3.8	68000310	41214-000877_UW - Main pcb supporter	CCW24B30A	1
3.9	68000345	41505-000232 - Electrical Box	CCW24B30A	1
3.1	68000322	42001-000058 - Cable Clamp	CCW24B30A	1
4	68000346	41504-000056 - Top Cover	CCW24B30A	1
5	68000347	41504-000051 - Back Surround Cover Plate	CCW24B30A	1
6	68000348	22001-000167_UW - Fan Motor	CCW24B30A	1
7	68000349	41504-000045_UW - Back Surround Plate	CCW24B30A	1
8	68000294	41503-000008_UW - Propeller Fan	CCW24B30A	1
9	68000350	92011-000773 - Condenser	CCW24B30A	1
10	68000351	41509-000046 - left Adjustable shade rail	CCW24B30A	1
11	68000352	41509-000018 - Adjustable shade	CCW24B30A	1
12	68000353	41214-000579 - Adjustable shade rod	CCW24B30A	1
13	68000354	41509-000025 - Up Adjustable shade rail	CCW24B30A	1
14	68000355	41508-000009_UW - Cabinet	CCW24B30A	1
15	68000356	41509-000036 - Right Adjustable shade rail	CCW24B30A	1
16	68000357	41504-000037 - Partition plate	CCW24B30A	1
17	68000358	41504-000144_UW - Back Vortex Shell	CCW24B30A	1
18	68000359	41503-000011_UW - Centrifugal Fan	CCW24B30A	1

# PARTS CATALOG

Chill Premier Models: CCW24B30A

Figure 903

ITEM	PART NUMBER	PART DESCRIPTION	USED ON MODEL	QTY
19	68000360	41504-000150_UW - Front Vortex Shell	CCW24B30A	1
20	68000361	92011-003350 - Evaporator	CCW24B30A	1
21	68000305	41605-000011 - Sensor Holder	CCW24B30A	1
22	68000362	92014-000276 - Compressor	CCW24B30A	1
23	68000363	41504-000098 - Water drainage pan	CCW24B30A	1
24	68000301	41214-000856 - Pipe Cover (two-way)	CCW24B30A	1
25	68000300	41214-000857 - Pipe Cover (four-way)	CCW24B30A	1
26	68000364	92007-003557 - cold tube	CCW24B30A	1
27	68000365	41502-000004_UW - Base	CCW24B30A	1
-28	68000331	22007-000067_UW - Power Supply Cord	CCW24B30A	1
-29	68000314	22013-000936 - Remote Controller	CCW24B30A	1
-30	68000232	10104-100026 - Sensor Assembly	CCW24B30A	1
-35	68000237	32001-000129 - WIFI Assembly	CCW24B30A	1
-ITEMS ARE NON- ILLUSTRATED				
*ITEMS ARE NON-STOCKED, WILL NORMALLY REQUIRE 2-3 WEEKS LEAD TIME				

# PARTS CATALOG

Chill Premier Models: CEW08B11A, CEW12B33A

Figure 904

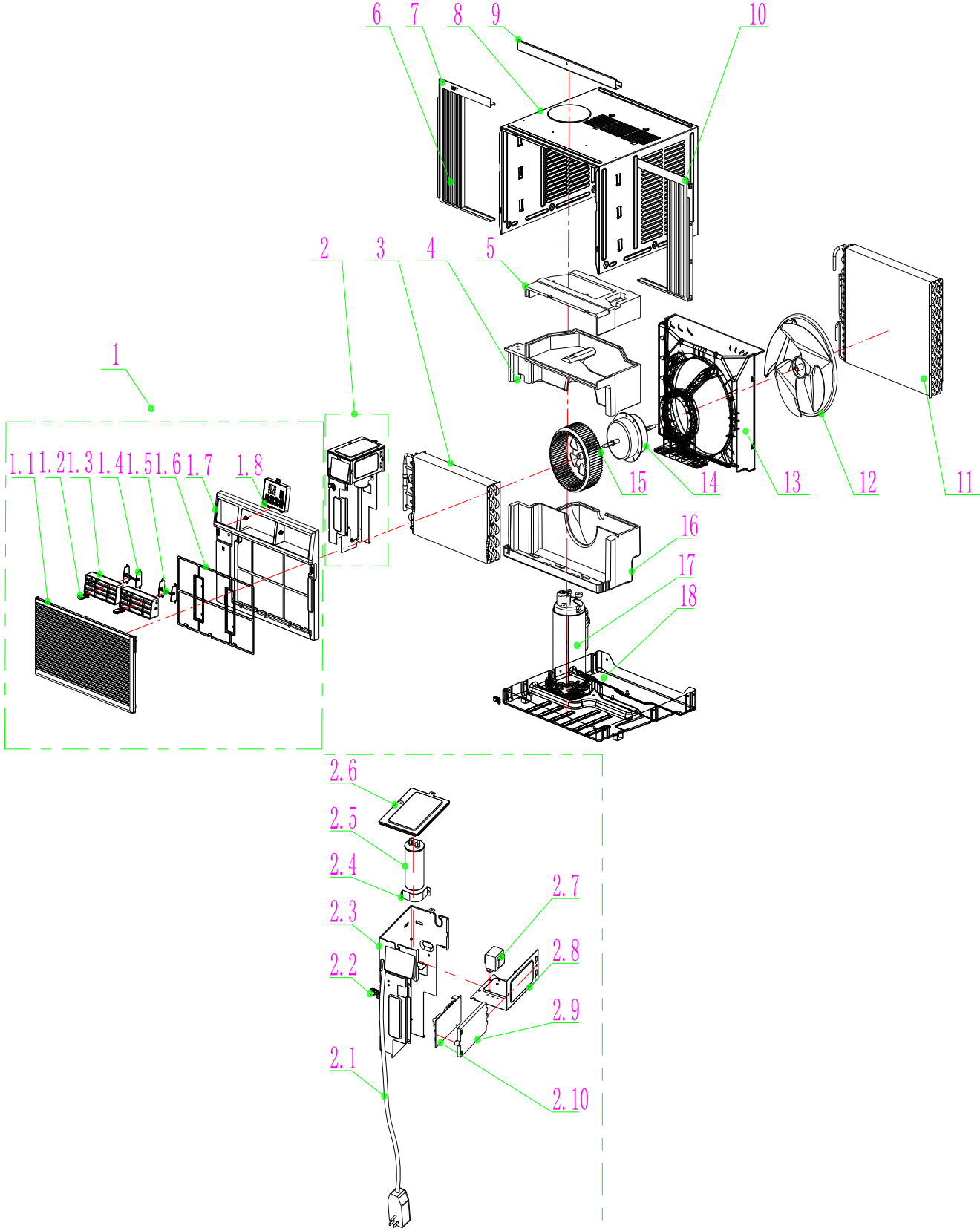

# PARTS CATALOG

Figure 904

Chill Premier Models: CEW08B11A, CEW12B33A

ITEM	PART NUMBER	PART DESCRIPTION	USED ON MODEL	QTY
<u>1</u>	68000449	Front Panel Assembly	ALL	1
1.1	68000165	Intake grille	ALL	1
1.2	68000167	swing rod	ALL	1
1.3	68000169	Leading Flow Circle	ALL	1
1.4	68000171	Louver	ALL	1
1.5	68000173	Louver Connector	ALL	1
1.6	68000175	Air Filter	ALL	1
1.7	68000177	Front Panel	ALL	1
1.8	68000179	Control Box panel	ALL	1
2	68000181	Electrical Box Assembly	ALL	1
2.1	68000256	Power Supply Cord	CEW08B11A	1
2.1	68000331	Power Supply Cord	CEW12B33A	1
2.2	68000257	Cable Clamp	CEW08B11A	1
2.2	68000322	Cable Clamp	CEW12B33A	1
2.3	68000187	Electrical Box	ALL	1
2.4	68000189	Capacitor Strip	ALL	1
2.5	68000193	Fan Capacitor	CEW08B11A	1
2.5	68000457	Compressor Capacitor	CEW12B33A	1
2.6	68000195	Electrical Box Cover	ALL	1
2.7	68000197	Transformer	CEW08B11A	1
2.7	68000328	Transformer	CEW12B33A	1
2.8	#N/A	Electrical Box base supporter	CEW12B33A	1
2.9	68000201	Main pcb supporter	ALL	1
2.10	68000450	Main pcb	CEW08B11A	1
2.10	68000421	Main pcb	CEW12B33A	1
3	68000245	Evaporator	CEW08B11A	1
3	68000458	Evaporator	CEW12B33A	1
4	68000451	Middle Vortex Shell	ALL	1
5	68000452	Up Vortex Shell	ALL	1
6	68000211	Adjustable shade	ALL	1
7	68000221	left Adjustable shade rail	ALL	1
8	68000222	Cabinet	ALL	1
8	68000222	Cabinet	ALL	1
9	68000223	Up Adjustable shade rail	ALL	1
10	68000224	Right Adjustable shade rail	ALL	1
11	68000205	Condenser	CEW08B11A	1
11	68000260	Condenser	CEW12B33A	1
12	68000225	Propeller Fan	ALL	1



# PARTS CATALOG

Figure 904

Chill Premier Models: CEW08B11A, CEW12B33A

ITEM	PART NUMBER	PART DESCRIPTION	USED ON MODEL	QTY
13	68000250	Back Surround Plate	ALL	1
14	68000227	Fan Motor	CEW08B11A	1
14	68000459	Fan Motor	CEW12B33A	1
15	68000453	Centrifugal Fan	ALL	1
16	68000229	Water drainage pan	ALL	1
17	68000254	Compressor	CEW08B11A	1
17	68000460	Compressor	CEW12B33A	1
18	68000454	Base	ALL	1
19	68000232	Sensor	ALL	1
20	68000315	Display PCB	ALL	1
21	68000455	carton	ALL	1
22	68000235	Base Carton Assembly	ALL	1
23	68000236	Top cover	ALL	1
24	68000237	WIFI Assembly	ALL	1
25	68000422	Remote Controller	ALL	1
26	68000456	Electric heating	CEW08B11A	1
26	68000461	Electric heating	CEW12B33A	1
-27	68000241	Compressor Capacitor	CEW08B11A	1
-ITEMS ARE NON- ILLUSTRATED				

# PARTS CATALOG

Chill Premier Models: CEW18B33A

Figure 905

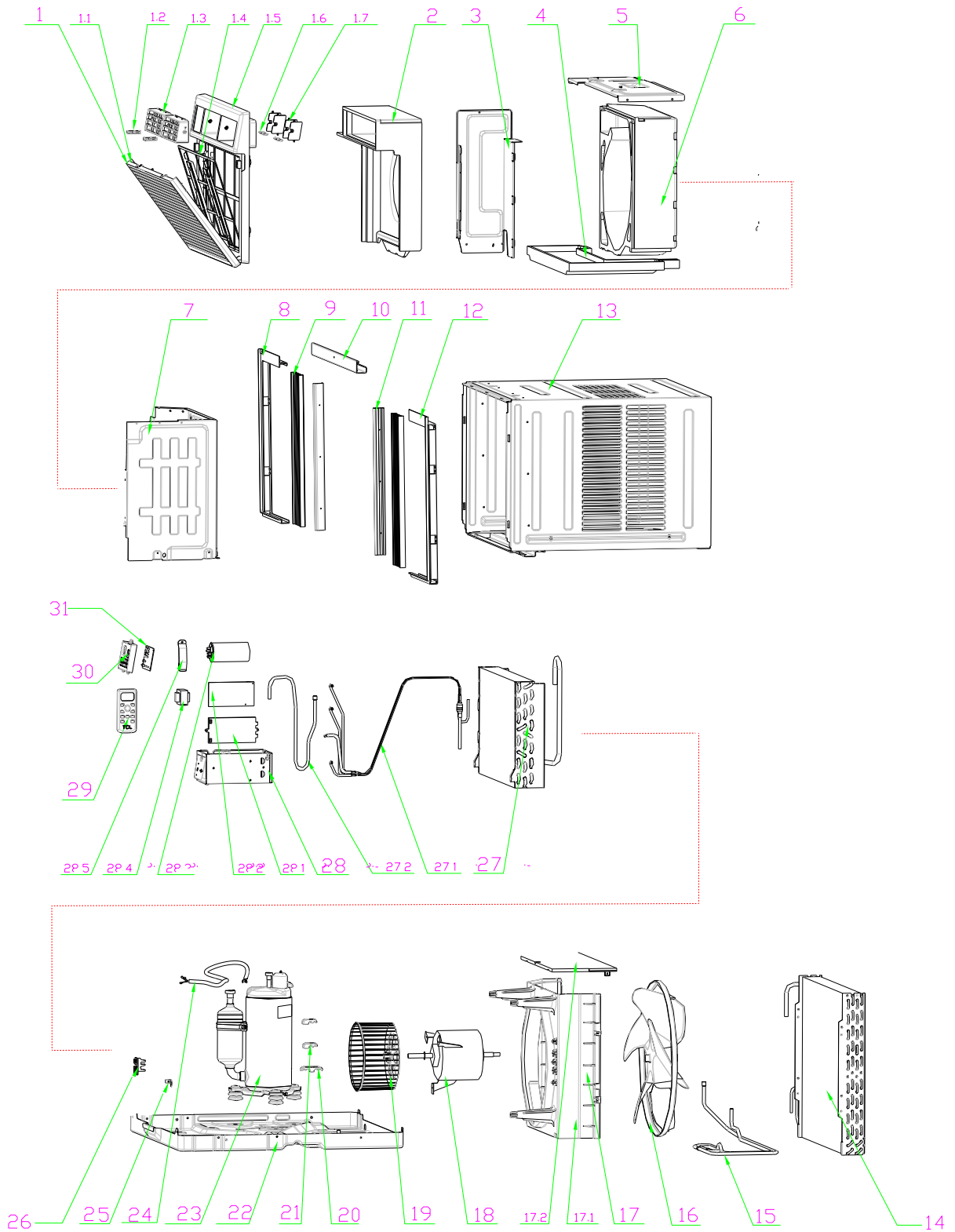

# PARTS CATALOG

Chill Premier Models: CEW18B33A

Figure 905

ITEM	PART NUMBER	PART DESCRIPTION	USED ON MODEL	QTY
1	68000273	41106-003518 - Front Panel Assembly	CEW18B1833A	1
1.1	68000274	41607-000080 - Intake grille	CEW18B1833A	1
1.2	68000167	41507-000106 - swing rod	CEW18B1833A	1
1.3	68000275	41507-000126 - Leading Flow Circle	CEW18B1833A	1
1.4	68000276	42008-000095 - Air Filter	CEW18B1833A	1
1.5	68000277	41607-000059 - Front Panel	CEW18B1833A	1
1.6	68000278	41507-000072 - Louver Connector	CEW18B1833A	1
1.7	68000279	41507-000098 - Louver	CEW18B1833A	1
2	68000415	41504-000088 - Front Vortex Shell(UP)	CEW18B1833A	1
3	68000417	41214-001077 - Electrical Box Cover supporter	CEW18B1833A	1
4	68000282	41504-000099 - Water drainage pan	CEW18B1833A	1
5	68000283	41504-000055 - Top plate	CEW18B1833A	1
6	68000418	41304-000072 - Back Vortex Shell	CEW18B1833A	1
7	68000285	41504-000038 - Partition plate	CEW18B1833A	1
8	68000286	41509-000040 - left Adjustable shade rail	CEW18B1833A	1
9	68000287	41509-000014 - Adjustable shade	CEW18B1833A	1
10	68000288	41509-000026 - Up Adjustable shade rail	CEW18B1833A	1
11	68000289	41214-000913 - Adjustable shade rod	CEW18B1833A	1
12	68000290	41509-000030 - Right Adjustable shade rail	CEW18B1833A	1
13	68000291	41608-000012 - Cabinet	CEW18B1833A	1
14	68000292	92011-000770 - Condenser	CEW18B1833A	1
15	68000293	92007-003562 - cold tube	CEW18B1833A	1
16	68000294	41503-000008 - Propeller Fan	CEW18B1833A	1
17	68000295	41706-000002 - Back Surround Plate Assembly	CEW18B1833A	1
17.1	68000296	41604-000010 - Back Surround Plate	CEW18B1833A	1
17.2	68000297	41504-000049 - Back Surround Cover Plate	CEW18B1833A	1
18	68000320	22001-000172 - Fan Motor	CEW18B1833A	1
19	68000419	41503-000012 - Centrifugal Fan	CEW18B1833A	1
20	68000300	41214-000857 - Pipe Cover (four-way)	CEW18B1833A	1

# PARTS CATALOG

Chill Premier Models: CEW18B33A

Figure 905

ITEM	PART NUMBER	PART DESCRIPTION	USED ON MODEL	QTY
21	68000301	41214-000856 - Pipe Cover (two-way)	CEW18B1833A	1
22	68000420	41602-000022 - Base	CEW18B1833A	1
23	68000321	92014-000275 - Compressor	CEW18B1833A	1
24	68000304	22007-000280 - Compressor wire	CEW18B1833A	1
25	68000322	42001-000058 - Cable Clamp	CEW18B1833A	1
26	68000305	41605-000011 - Sensor Holder	CEW18B1833A	1
27	68000323	92011-003349 - Evaporator	CEW18B1833A	1
27.1	68000324	92007-001525 - Capillary Assembly	CEW18B1833A	1
27.2	68000325	92006-000180 - Discharge Pipe	CEW18B1833A	1
28	68000309	41505-000233 - Electrical Box	CEW18B1833A	1
28.1	68000201	41214-000877 - Main pcb supporter	CEW18B1833A	1
28.2	68000421	31502-000010 - Main pcb	CEW18B1833A	1
28.3	68000327	10303-100040 - Capacitor	CEW18B1833A	1
28.4	68000328	10502-100034 - Transformer	CEW18B1833A	1
28.5	68000329	42001-000025 - Capacitor Strip	CEW18B1833A	1
29	68000422	22013-000789 - Remote Controller	CEW18B1833A	1
30	68000179	41507-000031 - Control Box panel	CEW18B1833A	1
31	68000315	31502-000027 - Display PCB	CEW18B1833A	1
32	68000331	22007-000067 - Power Supply Cord	CEW18B1833A	1
33	68000232	10104-100026 - Sensor Assembly	CEW18B1833A	1
34	68000423	22004-000067 - Electrically assisted heating	CEW18B1833A	1
38	68000237	32001-000129 - WIFI Assembly	CEW18B1833A	1
39	68000425	12501-100001 - battery	CEW18B1833A	1
40	68000426	41214-000499 - sponge (PU 1100X40X25)	CEW18B1833A	1
41	68000427	42006-000235 - sponge (PU 1050*50*3)	CEW18B1833A	1
42	68000428	41399-000023 - Insulating sponge	CEW18B1833A	1
43	68000288	41509-000026 - Up Adjustable shade rail	CEW18B1833A	1
44	68000429	41509-000006 - Adjustable shade Assembly	CEW18B1833A	1
45	68000430	41214-000132 - sash lock	CEW18B1833A	1
46	68000431	41214-000411 - Support plate	CEW18B1833A	1
47	68000432	50803-100002 - bolt( M6×18)	CEW18B1833A	1
48	68000433	50612-100010 - nut(M6)	CEW18B1833A	1

# PARTS CATALOG

Figure 905

Chill Premier Models: CEW18B33A

ITEM	PART NUMBER	PART DESCRIPTION	USED ON MODEL	QTY
49	68000434	50209-100009 - gasket(inner diameter 4.3x1.0)	CEW18B1833A	1
50	68000435	51307-100006 - screw(ST4.2x12)	CEW18B1833A	1
51	68000436	51314-100035 - screw(ST4.8x16-F-H)	CEW18B1833A	1
52	68000437	50704-100001 - bolt(M5x13)	CEW18B1833A	1
53	68000438	50610-100019 - screw(M5)	CEW18B1833A	1
54	68000439	51307-100005 - screw(ST4.8x8)	CEW18B1833A	1
-56	68000416	41504-000094 - Front Vortex Shell(DOWN)	CEW18B1833A	1
-ITEMS ARE NON- ILLUSTRATED *ITEMS ARE NON-STOCKED, WILL NORMALLY REQUIRE 2-3 WEEKS LEAD TIME				

# PARTS CATALOG

Figure 906

Chill Premier Models: CEW24B33A

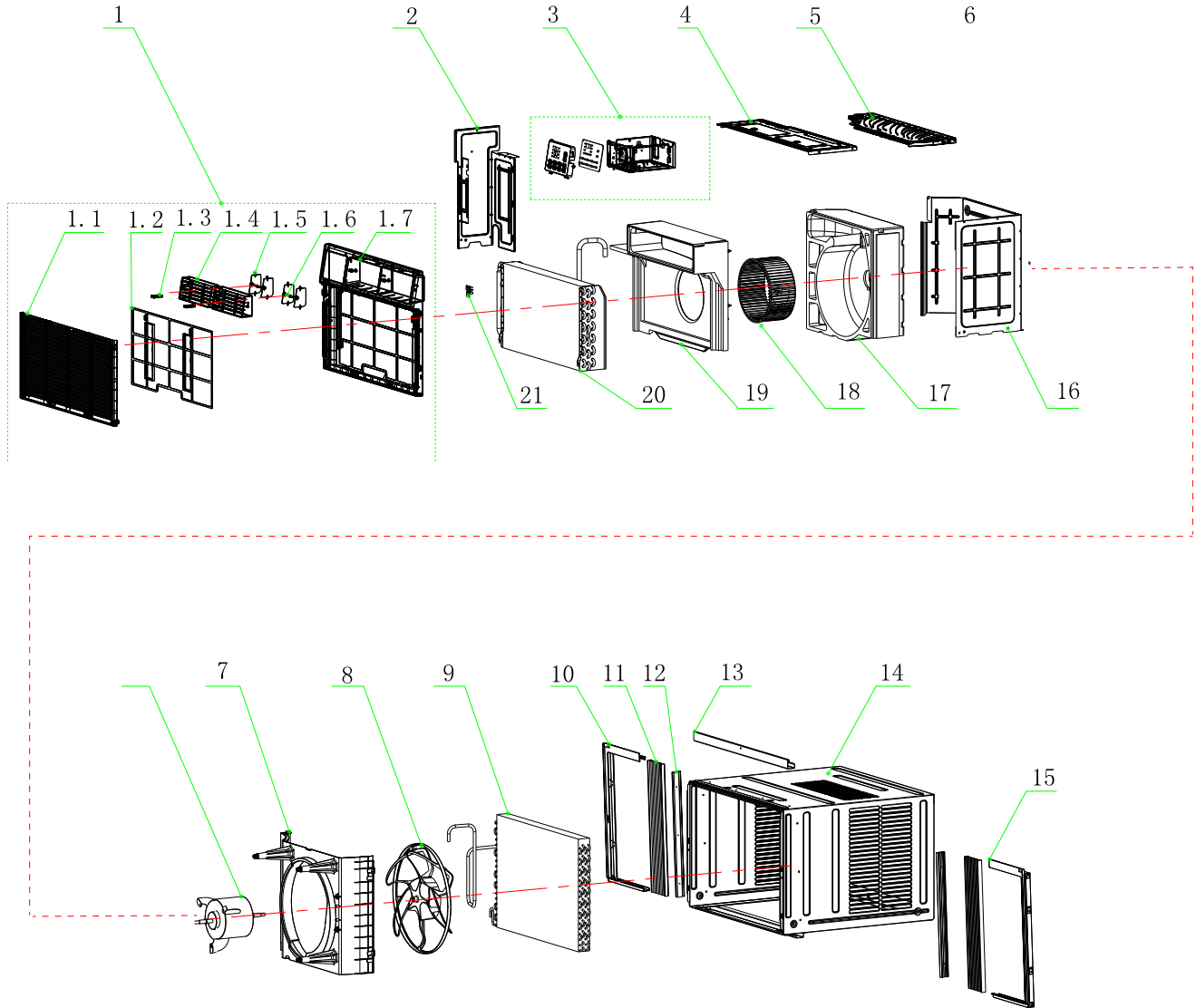

# PARTS CATALOG

Chill Premier Models: CEW24B33A

Figure 906

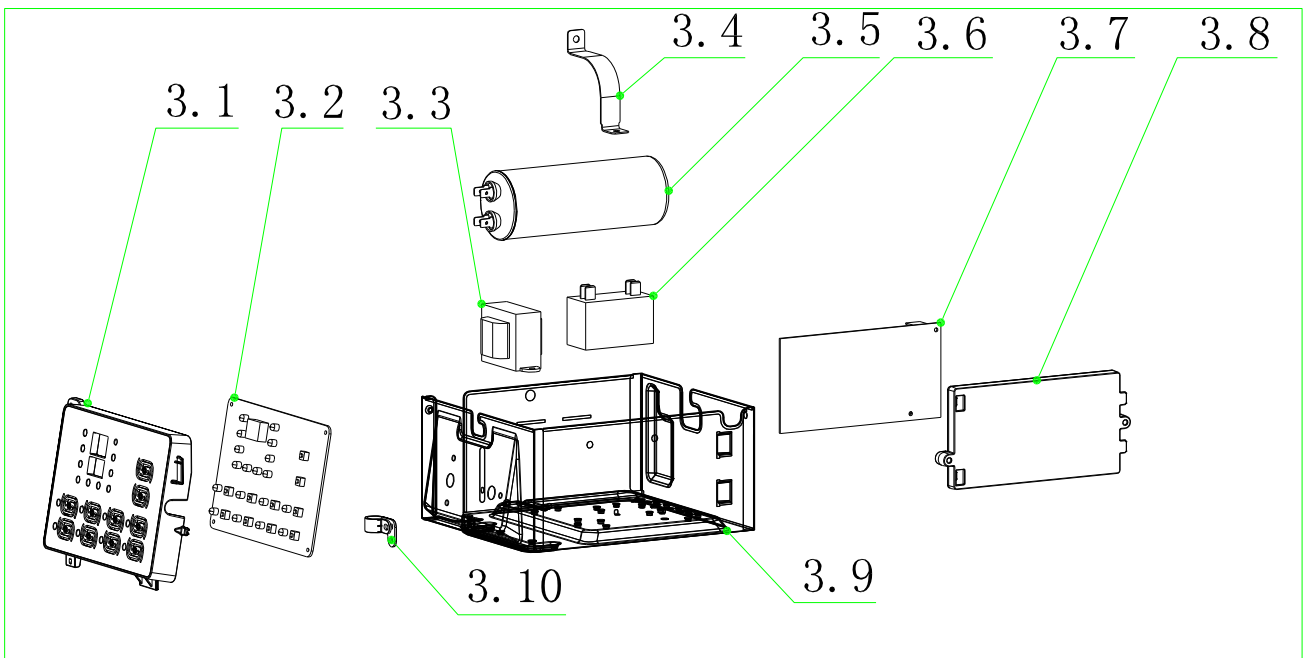
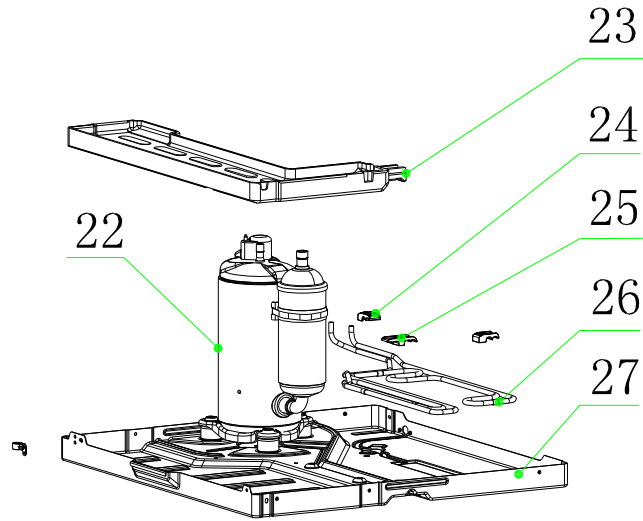

# PARTS CATALOG

Chill Premier Models: CEW24B33A

Figure 906

ITEM	PART NUMBER	PART DESCRIPTION	USED ON MODEL	QTY
1	68000441	41106-003887 - Front Panel Assembly	CEW24B33A	1
1.1	68000333	41507-000055 - Intake grille	CEW24B33A	1
1.2	68000334	41507-000137 - Air Filter	CEW24B33A	1
1.3	68000167	41507-000106 - swing rod	CEW24B33A	1
1.4	68000335	41507-000117 - Leading Flow Circle	CEW24B33A	1
1.5	68000336	41507-000093 - Louver	CEW24B33A	1
1.6	68000337	41507-000075 - Louver Connector	CEW24B33A	1
1.7	68000338	41507-000023 - Front Panel	CEW24B33A	1
2	68000442	41504-000054 - Left Supporter	CEW24B33A	1
3	68000340	41505-000229 - Electrical Box Assembly	CEW24B33A	1
3.1	68000322	42001-000058 - Cable Clamp	CEW24B33A	1
3.1	68000341	41507-000033 - Control Box panel	CEW24B33A	1
3.2	68000342	31502-000026 - Display PCB	CEW24B33A	1
3.3	68000328	10502-100034 - Transformer	CEW24B33A	1
3.4	68000189	42001-000027 - Capacitor Strip	CEW24B33A	1
3.5	68000343	22003-000006 - Compressor Capacitor	CEW24B33A	1
3.6	68000344	10303-100018 - Fan Motor Capacitor	CEW24B33A	1
3.7	68000421	31502-000010 - Main pcb	CEW24B33A	1
3.8	68000201	41214-000877 - Main pcb supporter	CEW24B33A	1
3.9	68000345	41505-000232 - Electrical Box	CEW24B33A	1
4	68000346	41504-000056 - Top Cover	CEW24B33A	1
5	68000347	41504-000051 - Back Surround Cover Plate	CEW24B33A	1
6	68000348	22001-000167 - Fan Motor	CEW24B33A	1
7	68000349	41504-000045 - Back Surround Plate	CEW24B33A	1
8	68000294	41503-000008 - Propeller Fan	CEW24B33A	1
9	68000350	92011-000773 - Condenser	CEW24B33A	1
10	68000351	41509-000046 - left Adjustable shade rail	CEW24B33A	1
11	68000352	41509-000018 - Adjustable shade	CEW24B33A	1
12	68000353	41214-000579 - Adjustable shade rod	CEW24B33A	1
13	68000354	41509-000025 - Up Adjustable shade rail	CEW24B33A	1
14	68000355	41508-000009 - Cabinet	CEW24B33A	1



ITEM	PART NUMBER	PART DESCRIPTION	USED ON MODEL	QTY
15	68000356	41509-000036 - Right Adjustable shade rail	CEW24B33A	1
16	68000357	41504-000037 - Partition plate	CEW24B33A	1
17	68000443	41304-000070 - Back Vortex Shell	CEW24B33A	1
18	68000419	41503-000012 - Centrifugal Fan	CEW24B33A	1
19	68000444	41504-000090 - Front Vortex Shell□UP□	CEW24B33A	1
20	68000361	92011-003350 - Evaporator	CEW24B33A	1
21	68000305	41605-000011 - Sensor Holder	CEW24B33A	1
22	68000362	92014-000276 - Compressor	CEW24B33A	1
23	68000363	41504-000098 - Water drainage pan	CEW24B33A	1
24	68000301	41214-000856 - Pipe Cover (two-way)	CEW24B33A	1
25	68000300	41214-000857 - Pipe Cover (four-way)	CEW24B33A	1
26	68000364	92007-003557 - cold tube	CEW24B33A	1
27	68000446	41502-000015 - Base	CEW24B33A	1
28	68000331	22007-000067 - Power Supply Cord	CEW24B33A	1
29	68000423	22004-000067 - Electrically assisted heating	CEW24B33A	1
30	68000237	32001-000129 - WIFI Assembly	CEW24B33A	1
31	68000422	22013-000789 - Remote Controller	CEW24B33A	1
32	68000232	10104-100026 - Sensor Assembly	CEW24B33A	1
33	68000366	41110-000316 - Cover Forming	CEW24B33A	1
34	68000219	A1202-000038 - Base Forming	CEW24B33A	1
35	68000220	A2005-000537 - Base Carton	CEW24B33A	1
36	68000425	12501-100001 - battery	CEW24B33A	1
37	68000447	41509-000002 - Adjustable shade Assembly	CEW24B33A	1
38	68000354	41509-000025 - Up Adjustable shade rail	CEW24B33A	1
39	68000426	41214-000499 - sponge (PU 1100X40X25)	CEW24B33A	1
40	68000427	42006-000235 - sponge (PU 1050*50*3)	CEW24B33A	1
41	68000448	41399-000026 - Insulating sponge	CEW24B33A	1
42	68000430	41214-000132 - sash lock	CEW24B33A	1
43	68000431	41214-000411 - Support plate	CEW24B33A	1
44	68000432	50803-100002 - bolt( M6×18)	CEW24B33A	1
45	68000433	50612-100010 - nut(M6)	CEW24B33A	1
46	68000434	50209-100009 - gasket(inner diameter□4.3×t1.0)	CEW24B33A	1
47	68000435	51307-100006 - screw(ST4.2×12)	CEW24B33A	1

ITEM	PART NUMBER	PART DESCRIPTION	USED ON MODEL	QTY
48	68000436	51314-100035 - screw(ST4.8×16-F-H)	CEW24B33A	1
49	68000437	50704-100001 - bolt(M5×13)	CEW24B33A	1
50	68000438	50610-100019 - screw(M5)	CEW24B33A	1
51	68000439	51307-100005 - screw(ST4.8×8)	CEW24B33A	1
52	68000440	211407853 - Packaging plastic bags	CEW24B33A	1
-53	68000445	41504-000092 - Front Vortex Shell (DOWN)	CEW24B33A	1
1-ITEMS ARE NON- ILLUSTRATED *ITEMS ARE NON-STOCKED, WILL NORMALLY REQUIRE 2-3 WEEKS LEAD TIME				

# PARTS CATALOG

Chill Premier Models: CCF05A10A CCF06A10A CCF08A10A

Figure 907

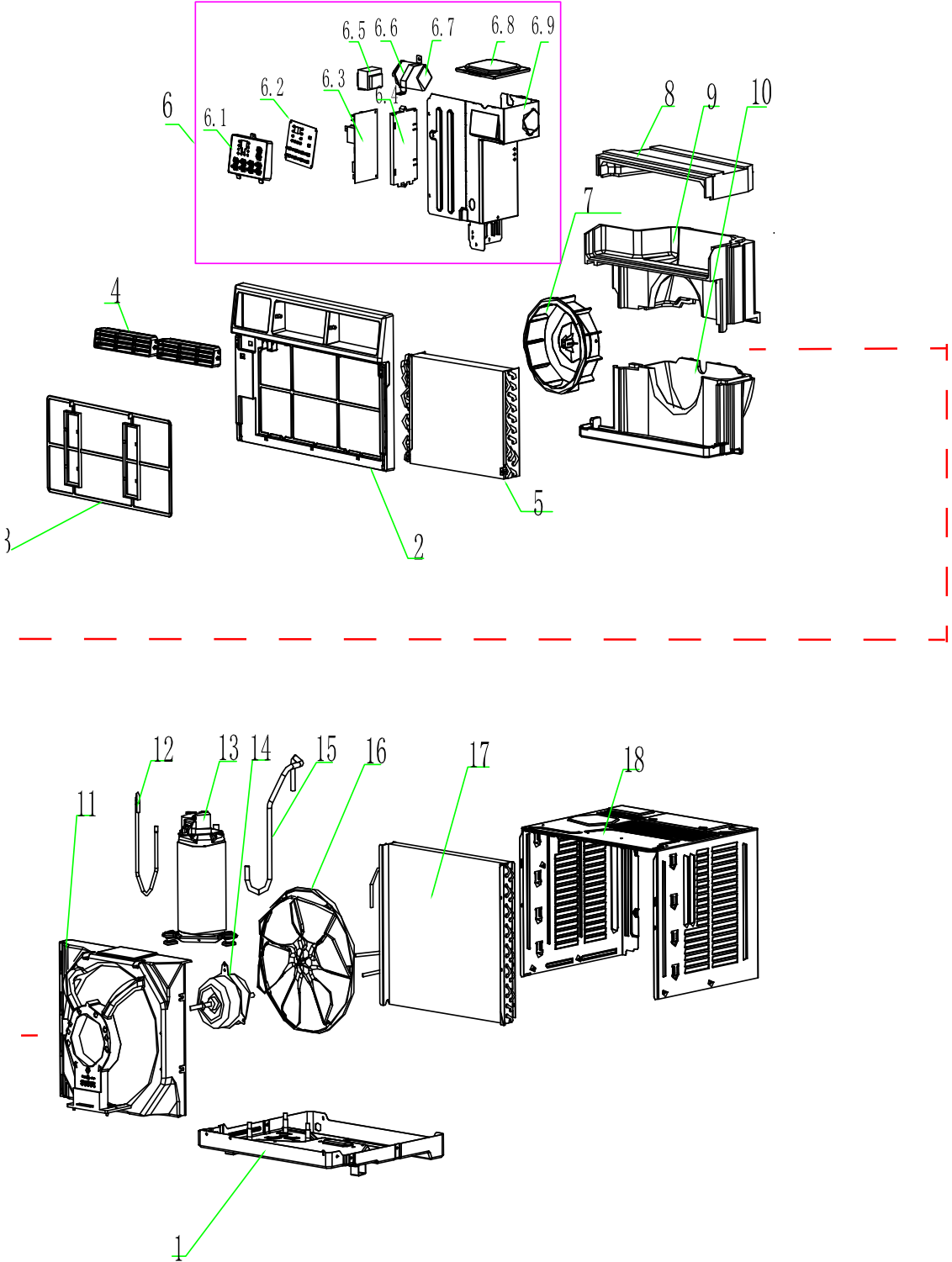

# PARTS CATALOG

Figure 907

Chill Premier Models: CCF05A10A CCF06A10A CCF08A10A

ITEM	PART NUMBER	PART DESCRIPTION	USED ON MODEL	QTY
1	68000216	210826698 - Base	CCF05A10A, CCF06A10A	1
1A	68000145	210826701 - Base	CCF08A10A	1
2	68000218	210755572 - Front Panel Assembly	CCF05A10A, CCF06A10A, CCF08A10A	1
3	68000014	210736640A - Air Filter	CCF05A10A, CCF06A10A, CCF08A10A	1
4	68000008	210755573 - Leading Flow Circle	CCF05A10A, CCF06A10A, CCF08A10A	1
5	68000118	211241456 - Evaporator	CCF05A10A, CCF06A10A	1
5A	68000146	211241581 - Evaporator	CCF08A10A	1
6	68000119	214146283C - Electrical Assembly	CCF05A10A, CCF06A10A	1
6A	68000147	214169039 - Electrical Assembly	CCF08A10A	1
6.1	68000120	210736632 - Control Box panel	CCF05A10A, CCF06A10A, CCF08A10A	1
6.2	68000029	210901461E - display pcb	CCF05A10A, CCF06A10A, CCF08A10A	1
6.3	68000015	210901411N - Main pcb	CCF05A10A, CCF06A10A, CCF08A10A	1
6.4	68000065	210736568 - Main pcb supporter	CCF05A10A, CCF06A10A, CCF08A10A	1
6.5	68000040	210901721 - Transformer	CCF05A10A, CCF06A10A, CCF08A10A	1
6.6	68000121	210826496 - Capacitor Strip	CCF05A10A, CCF06A10A, CCF08A10A	1
6.7	68000009	210901420 - Capacitor	CCF05A10A, CCF06A10A	1
6.7A	68000025	210901421 - Capacitor	CCF08A10A	1
6.8	68000122	210826675 - Electrical Box Cover	CCF05A10A, CCF06A10A	1
6.8A	68000148	210826680 - Electrical Box Cover	CCF08A10A	1
7	68000010	210736634 - Centrifugal Fan	CCF05A10A, CCF06A10A	1
7A	68000016	210736645 - Centrifugal Fan	CCF08A10A	1
8	68000123	210736642A - Up Vortex Shell	CCF05A10A, CCF06A10A	1
8A	68000150	210736646A - Up Vortex Shell	CCF08A10A	1
9	68000124	210736643A - Middle Vortex Shell	CCF05A10A, CCF06A10A	1
9A	68000151	210736647A - Middle Vortex Shell	CCF08A10A	1
10	68000125	210736644A - Down Vortex Shell	CCF05A10A, CCF06A10A	1
10A	68000152	210736648A - Down Vortex Shell	CCF08A10A	1
11	68000053	210736635A - Back Partition plate	CCF05A10A, CCF06A10A, CCF08A10A	1
12	68000126	211244320 - Discharge Pipe	CCF05A10A	1
12a	68000143	211241569 - Discharge Pipe	CCF06A10A	1
12B	68000153	211241653 - Discharge Pipe	CCF08A10A	1
13	68000217	211233963 - Compressor	CCF05A10A	1
13a	68000073	211234046 - Compressor	CCF06A10A	1
13B	68000154	211234047 - Compressor	CCF08A10A	1
14	68000011	210901425 - Fan Motor	CCF05A10A, CCF06A10A	1
14A	68000017	210901424 - Fan Motor	CCF08A10A	1
15	68000127	211233812 - Suction Pipe	CCF05A10A, CCF06A10A	1
15A	68000155	211233801 - Suction Pipe	CCF08A10A	1

# PARTS CATALOG

Figure 907

Chill Premier Models: CCF05A10A CCF06A10A CCF08A10A

ITEM	PART NUMBER	PART DESCRIPTION	USED ON MODEL	QTY
16	68000018	210736633 - Propeller Fan	CCF05A10A, CCF06A10A, CCF08A10A	1
17	68000128	211237530B - Condenser	CCF05A10A	1
17a	68000144	211241574B - Condenser	CCF06A10A	1
17B	68000156	211241577B - Condenser	CCF08A10A	1
18	68000012	210826699 - Cabinet	CCF05A10A, CCF06A10A	1
18A	68000019	210826702 - Cabinet	CCF08A10A	1
22	68000036	210902158A - Remote Controller	CCF05A10A, CCF06A10A, CCF08A10A	1
23	68000020	210901453 - Power Supply Cord	CCF05A10A, CCF06A10A, CCF08A10A	1
24	68000021	210901454 - Sensor Assembly	CCF05A10A, CCF06A10A, CCF08A10A	1
25	68000061	214169183 - installation accessories	CCF05A10A, CCF06A10A, CCF08A10A	1
25.1	68000133	210737549 - Insulation strip sponge	CCF05A10A, CCF06A10A, CCF08A10A	1
25.2	68000134	210737020 - Window Sash seal	CCF05A10A, CCF06A10A, CCF08A10A	1
25.3	68000135	210737051 - Foam Top window Gasket	CCF05A10A, CCF06A10A, CCF08A10A	1
25.4	68000022	210826772 - Top mounting Rail	CCF05A10A, CCF06A10A, CCF08A10A	1
25.5	68000023	210755639 - Filler Panels	CCF05A10A, CCF06A10A, CCF08A10A	1
25.6	68000023	210755640 - Filler Panels left Rail	CCF05A10A, CCF06A10A, CCF08A10A	1
25.7	68000023	210755641 - Filler Panels right Rail	CCF05A10A, CCF06A10A, CCF08A10A	1
25.8	68000023	211353335A - Filler Panels bag	CCF05A10A, CCF06A10A, CCF08A10A	1
25.9	68000136	214146620 - Screw accessories	CCF05A10A, CCF06A10A, CCF08A10A	1
25.9.1	68000137	1193070510 - Screw bag	CCF05A10A, CCF06A10A, CCF08A10A	1
25.9.2	68000138	210826603 - Sash lock	CCF05A10A, CCF06A10A, CCF08A10A	1
25.9.3	68000139	210826602 - Lock Frame	CCF05A10A, CCF06A10A, CCF08A10A	1
25.9.4	68000140	1180010035 - screw 4.2*9.5	CCF05A10A, CCF06A10A, CCF08A10A	1
25.9.5	68000141	1180010019 - screw 4.2*13	CCF05A10A, CCF06A10A, CCF08A10A	1
25.9.6	68000142	1180010025 - screw 4.2*19	CCF05A10A, CCF06A10A, CCF08A10A	1
26	68000039	214154672 - Wifi module	CCF05A10A, CCF06A10A, CCF08A10A	1
-ITEMS ARE NON- ILLUSTRATED				
*ITEMS ARE NON-STOCKED, WILL NORMALLY REQUIRE 2-3 WEEKS LEAD TIME				

# PARTS CATALOG

Chill Premier Models: CCF10A10A CCF12A10A

Figure 908

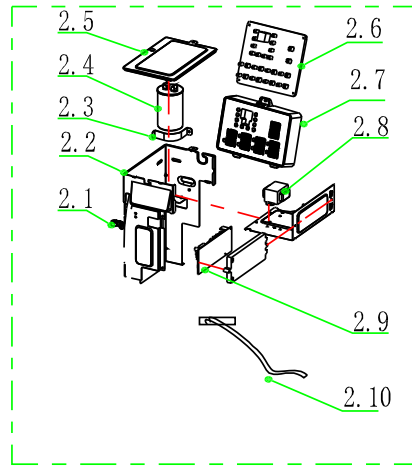
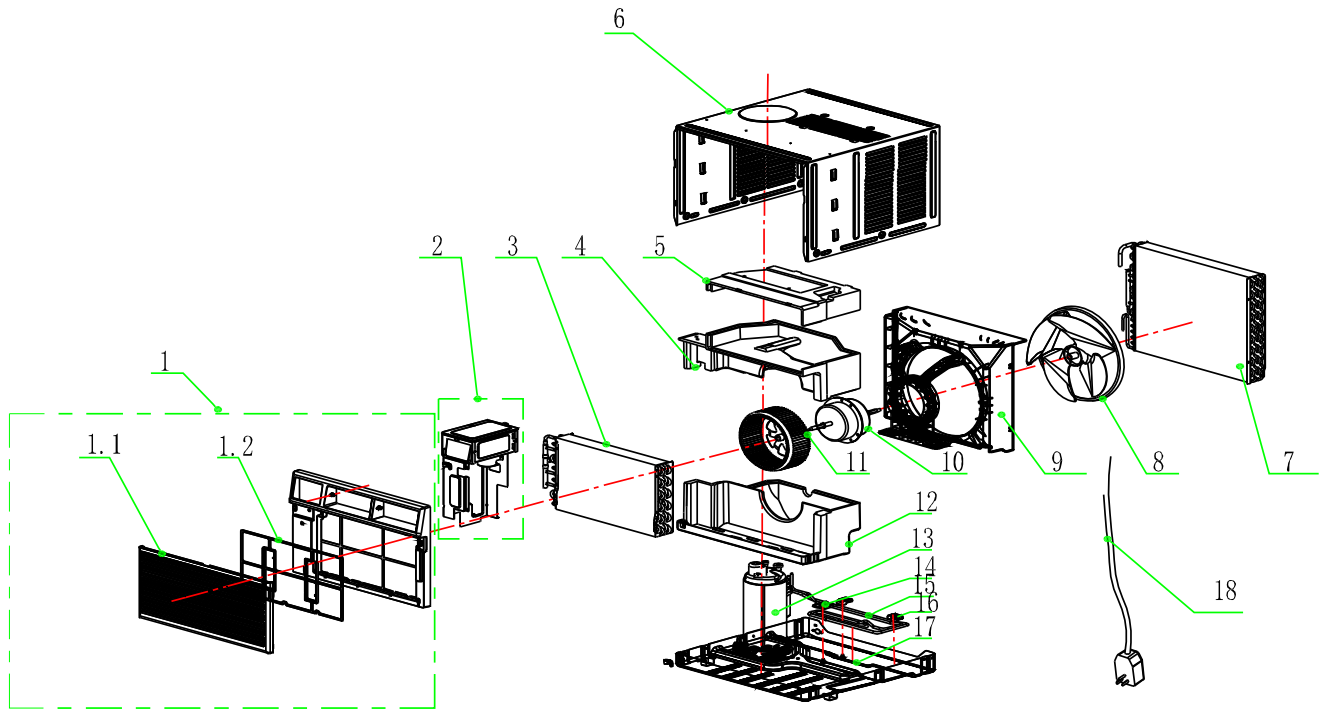

# PARTS CATALOG

Figure 908

## Chill Premier Models: CCF10A10A CCF12A10A

ITEM	PART NUMBER	PART DESCRIPTION	USED ON MODEL	QTY
1	68000160	214146537B - Front Panel Assembly	CCF10A10A, CCF12A10A	1
1.1	68000024	210755514 - Intake grille	CCF10A10A, CCF12A10A	1
1.2	68000027	210736617A - Air Filter	CCF10A10A, CCF12A10A	1
2	68000161	214146589D - Electrical Assembly	CCF10A10A, CCF12A10A	1
2.1	68000162	210736672 - Cable Clamp	CCF10A10A, CCF12A10A	1
2.2	68000164	210826720 - Electrical Box Assembly	CCF10A10A, CCF12A10A	1
2.3	68000121	210826496 - Capacitor Strip	CCF10A10A, CCF12A10A	1
2.4	68000025	210901421 - Capacitor	CCF10A10A	1
2.4A	68000028	210901423 - Capacitor	CCF12A10A	1
2.5	68000166	210826683 - Electrical Box Cover	CCF12A10A	1
2.6	68000029	210901461E - Display PCB	CCF10A10A, CCF12A10A	1
2.7	68000168	210736561 - Control Box panel	CCF10A10A, CCF12A10A	1
2.8	68000040	210901721 - Transformer	CCF10A10A, CCF12A10A	1
2.9	68000030	210901411P - Main pcb	CCF10A10A, CCF12A10A	1
2.10	68000031	210901539 - Sensor Assembly	CCF10A10A, CCF12A10A	1
3	68000170	211234445 - Evaporator	CCF10A10A	1
3A	68000200	211234361 - Evaporator	CCF12A10A	1
4	68000172	210736652A - Middle Vortex Shell	CCF10A10A, CCF12A10A	1
5	68000174	210736651A - Up Vortex Shell	CCF10A10A, CCF12A10A	1
6	68000176	214146541 - Cabinet	CCF10A10A, CCF12A10A	1
7	68000178	211234443B - Condenser	CCF10A10A	1
7A	68000202	211234345B - Condenser	CCF12A10A	1
8	68000032	210736728 - Propeller Fan	CCF10A10A, CCF12A10A	1
9	68000180	210736621A - Back Surround Plate	CCF10A10A, CCF12A10A	1
10	68000033	210901435 - Fan Motor	CCF10A10A, CCF12A10A	1
11	68000034	210736727 - Centrifugal Fan	CCF10A10A, CCF12A10A	1
12	68000182	210736653A - Down Vortex Shell	CCF10A10A, CCF12A10A	1
13	68000184	211234297 - Compressor	CCF10A10A	1
13A	68000204	211234298 - Compressor	CCF12A10A	1
14	68000206	210736570 - Pipe Cover (two-way)	CCF12A10A	1
15	68000208	211234354 - cold tube	CCF12A10A	1
16	68000210	210736569 - Pipe Cover (four-way)	CCF12A10A	1
17	68000186	210826728 - Base	CCF10A10A, CCF12A10A	1
18	68000035	210901453A - Power Supply Cord	CCF10A10A, CCF12A10A	1
19	68000188	211351575AU - carton	CCF10A10A, CCF12A10A	1
20	68000190	211351574 - Base Carton	CCF10A10A, CCF12A10A	1
21	68000192	211350337 - Base Foaming	CCF10A10A, CCF12A10A	1

# PARTS CATALOG

Figure 908

Chill Premier Models: CCF10A10A CCF12A10A

ITEM	PART NUMBER	PART DESCRIPTION	USED ON MODEL	QTY
22	68000194	211350338 - Top cover	CCF10A10A, CCF12A10A	1
23	68000036	210902158A - Remote Controller	CCF10A10A, CCF12A10A	1
24	68000196	210755642 - installation accessories	CCF10A10A, CCF12A10A	1
24.1	68000198	210737550 - Insulation strip sponge	CCF10A10A, CCF12A10A	1
24.2	68000134	210737020 - Window Sash seal	CCF10A10A, CCF12A10A	1
24.3	68000135	210737051 - Foam Top window Gasket	CCF10A10A, CCF12A10A	1
24.4	68000212	210755644 - Filler Panels	CCF10A10A, CCF12A10A	1
24.5	68000213	210755645 - Filler Panels Left Rail	CCF10A10A, CCF12A10A	1
24.6	68000214	210755646 - Filler Panels Right Rail	CCF10A10A, CCF12A10A	1
24.7	68000215	211354038A - Filler Panels bag	CCF10A10A, CCF12A10A	1
24.8	68000136	214146620 - Screw accessories	CCF10A10A, CCF12A10A	1
24.8.1	68000137	1193070510 - Screw bag	CCF10A10A, CCF12A10A	1
24.8.2	68000138	210826603 - Sash lock	CCF10A10A, CCF12A10A	1
24.8.3	68000139	210826602 - Lock Frame	CCF10A10A, CCF12A10A	1
24.8.4	68000140	1180010035 - screw 4.2*9.5	CCF10A10A, CCF12A10A	1
24.8.5	68000141	1180010019 - screw 4.2*13	CCF10A10A, CCF12A10A	1
24.8.6	68000142	1180010025 - screw 4.2*19	CCF10A10A, CCF12A10A	1
25	68000038	210826820 - Top mounting Rail	CCF10A10A, CCF12A10A	1
26	68000039	214154672 - Wifi module	CCF10A10A, CCF12A10A	1
-ITEMS ARE NON- ILLUSTRATED				
*ITEMS ARE NON-STOCKED, WILL NORMALLY REQUIRE 2-3 WEEKS LEAD TIME				



# PARTS CATALOG

Unifit Models: UCT08A10A UCT10A10A UCT12A10A UCT10A30A

Figure 909

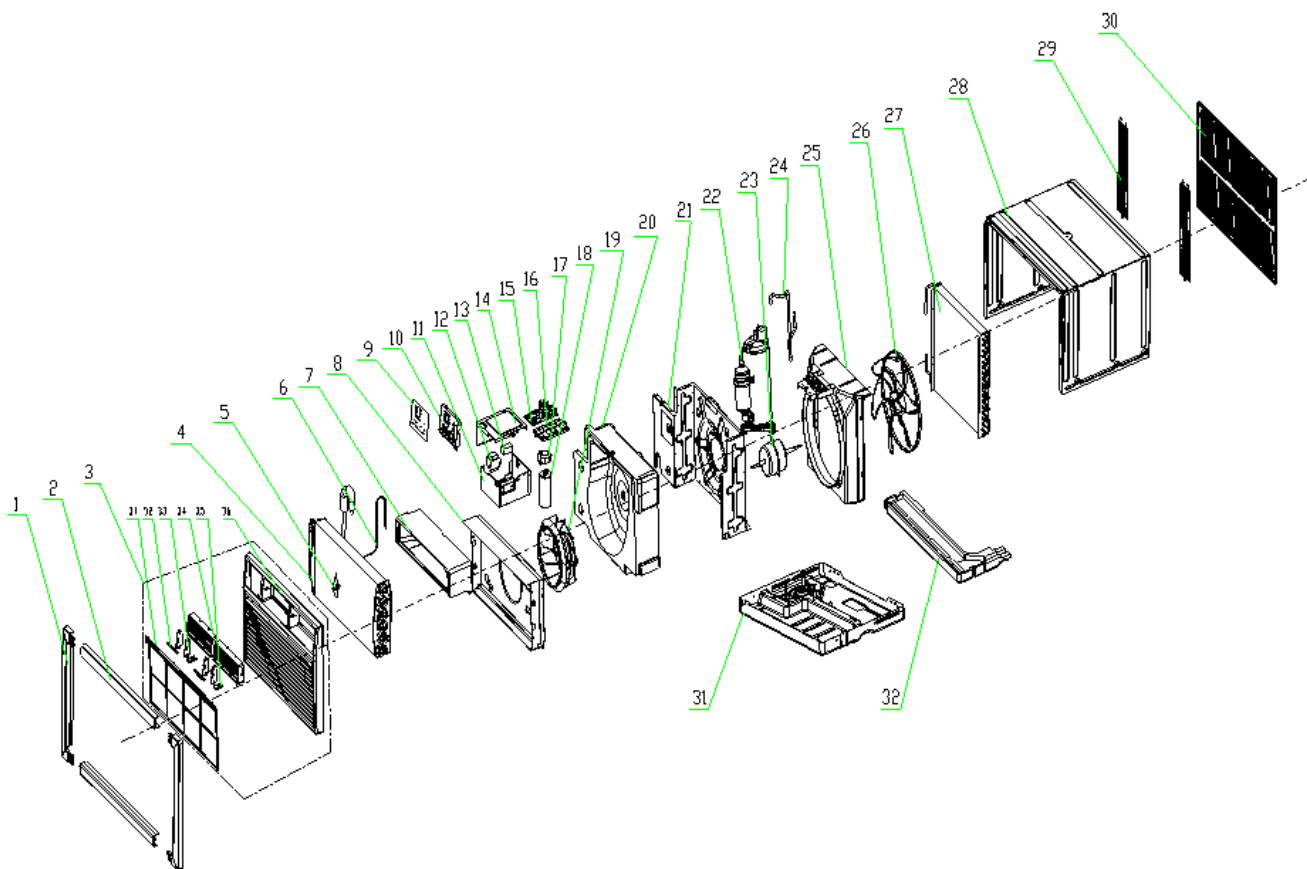

ITEM	PART NUMBER	PART DESCRIPTION	USED ON MODEL	QTY
1	68000055	210738331 - Display decorative piece1	UCT08A10A, UCT10A10A, UCT12A10A, UCT10A30A	1
2	68000056	210738332 - Display decorative piece2	UCT08A10A, UCT10A10A, UCT12A10A, UCT10A30A	1
3	68000057	210755503 - Front Panel Assembly	UCT08A10A, UCT10A10A, UCT12A10A, UCT10A30A	1
3.1	68000058	210755506 - Air Filter	UCT08A10A, UCT10A10A, UCT12A10A, UCT10A30A	1
4	68000373	211244404 - Evaporator	UCT08A10A,	1
4A	68000391	211238697 - Evaporator	UCT10A10A, UCT10A30A	1
4B	68000398	211238079 - Evaporator	UCT12A10A	1
5	#N/A	#N/A	UCT08A10A, UCT10A10A, UCT12A10A, UCT10A30A	1
6	68000374	211244403 - Capillary Assembly	UCT08A10A	1
6A	68000392	211238698 - Capillary Assembly	UCT10A10A, UCT10A30A	1
6B	68000399	211238080 - Capillary Assembly	UCT12A10A	1
7	68000375	210738268A - Outlet foam	UCT08A10A, UCT10A10A, UCT12A10A, UCT10A30A	1
8	68000376	210836747 - Front Partition plate	UCT08A10A, UCT10A10A, UCT12A10A, UCT10A30A	1

# PARTS CATALOG

Figure 909

Unifit Models: UCT08A10A UCT10A10A UCT12A10A UCT10A30A

ITEM	PART NUMBER	PART DESCRIPTION	USED ON MODEL	QTY
9	68000377	210755615A - Display PCB cover	UCT08A10A, UCT10A10A, UCT12A10A, UCT10A30A	1
10	68000132	210738277 - Control Box panel	UCT08A10A, UCT10A10A, UCT12A10A, UCT10A30A	1
11	68000378	210836910 - Electrical Box	UCT08A10A, UCT10A10A, UCT12A10A, UCT10A30A	1
12	68000040	210901721 - Transformer	UCT08A10A, UCT10A10A, UCT12A10A	1
12A	68000062	210901700 - Transformer	UCT10A30A	1
13	68000041	210901745 - Fan Motor Capacitor	UCT08A10A, UCT10A10A, UCT12A10A, UCT10A30A	1
14	68000379	210836752 - Electrical Box Cover	UCT08A10A, UCT10A10A, UCT12A10A, UCT10A30A	1
15	68000030	210901411P - Main pcb	UCT08A10A, UCT10A10A, UCT12A10A, UCT10A30A	1
16	68000065	210736568 - Main pcb supporter	UCT08A10A, UCT10A10A, UCT12A10A, UCT10A30A	1
17	68000380	210738282 - Capacitor Strip	UCT08A10A, UCT10A10A, UCT12A10A, UCT10A30A	1
18	68000043	1170100033A - Compressor Capacitor	UCT08A10A	1
18A	68000000	1170100007C - Compressor Capacitor	UCT10A10A	1
18B	68000047	1170100023A - Compressor Capacitor	UCT10A30A	1
18C	68000001	210901831 - Compressor Capacitor	UCT12A10A	1
19	68000006	210738336 - Centrifugal Fan	UCT08A10A, UCT10A10A, UCT12A10A, UCT10A30A	1
20	68000381	210738267A - foam shell	UCT08A10A, UCT10A10A, UCT12A10A, UCT10A30A	1
21	68000382	210836909A - Partition plate	UCT08A10A, UCT10A10A, UCT12A10A, UCT10A30A	1
22	68000383	211237425 - Compressor	UCT08A10A	1
22A	68000393	211236834 - Compressor	UCT10A10A	1
22B	68000396	211231767 - Compressor	UCT10A30A	1
22C	68000400	211238084 - Compressor	UCT12A10A	1
23	68000044	210901757 - Fan Motor	UCT08A10A, UCT10A10A	1
23A	68000068	210901723 - Fan Motor	UCT10A30A	1
23B	68000002	210901722 - Fan Motor	UCT12A10A	1
24	68000384	211237435 - Discharge Pipe	UCT08A10A	1
24A	68000394	211238696 - Discharge Pipe	UCT10A10A	1
24B	68000394	211238696 - Discharge Pipe	UCT10A30A	1
24C	68000401	211236902 - Discharge Pipe	UCT12A10A	1
25	68000069	210738266A - Back Partition plate	UCT08A10A, UCT10A10A, UCT12A10A, UCT10A30A	1
26	68000070	210738337 - Propeller Fan	UCT08A10A, UCT10A10A, UCT12A10A, UCT10A30A	1
27	68000385	211236831B - Condenser	UCT08A10A, UCT10A10A, UCT12A10A, UCT10A30A	1
27A	68000402	211236922B - Condenser	UCT12A10A	1
28	68000071	210836745 - Cabinet	UCT08A10A, UCT10A10A, UCT12A10A, UCT10A30A	1
29	68000072	210836793 - grille	UCT08A10A, UCT10A10A, UCT12A10A, UCT10A30A	1

# PARTS CATALOG

Unifit Models: UCT08A10A UCT10A10A UCT12A10A UCT10A30A

Figure 909

ITEM	PART NUMBER	PART DESCRIPTION	USED ON MODEL	QTY
30	68000048	210836767 - intake and outtake grille	UCT08A10A, UCT10A10A, UCT12A10A, UCT10A30A	1
31	68000386	210836781A - Base	UCT08A10A, UCT10A10A, UCT12A10A, UCT10A30A	1
32	68000051	210738265 - Water drainage pan	UCT08A10A, UCT10A10A, UCT12A10A, UCT10A30A	1
-34	68000035	210901453A - Power Supply Cord	UCT08A10A, UCT10A10A, UCT12A10A	1
-34A	68000397	210901453E - Power Supply Cord	UCT10A30A	1
-35	68000036	210902158A - Remote Controller	UCT08A10A, UCT10A10A, UCT12A10A, UCT10A30A	1
-36	68000054	210901730A - Display PCB	UCT08A10A, UCT10A10A, UCT12A10A, UCT10A30A	1
-ITEMS ARE NON- ILLUSTRATED *ITEMS ARE NON-STOCKED, WILL NORMALLY REQUIRE 2-3 WEEKS LEAD TIME				

# PARTS CATALOG

Unifit Models: UCT12A30, UCT14A30A

Figure 910

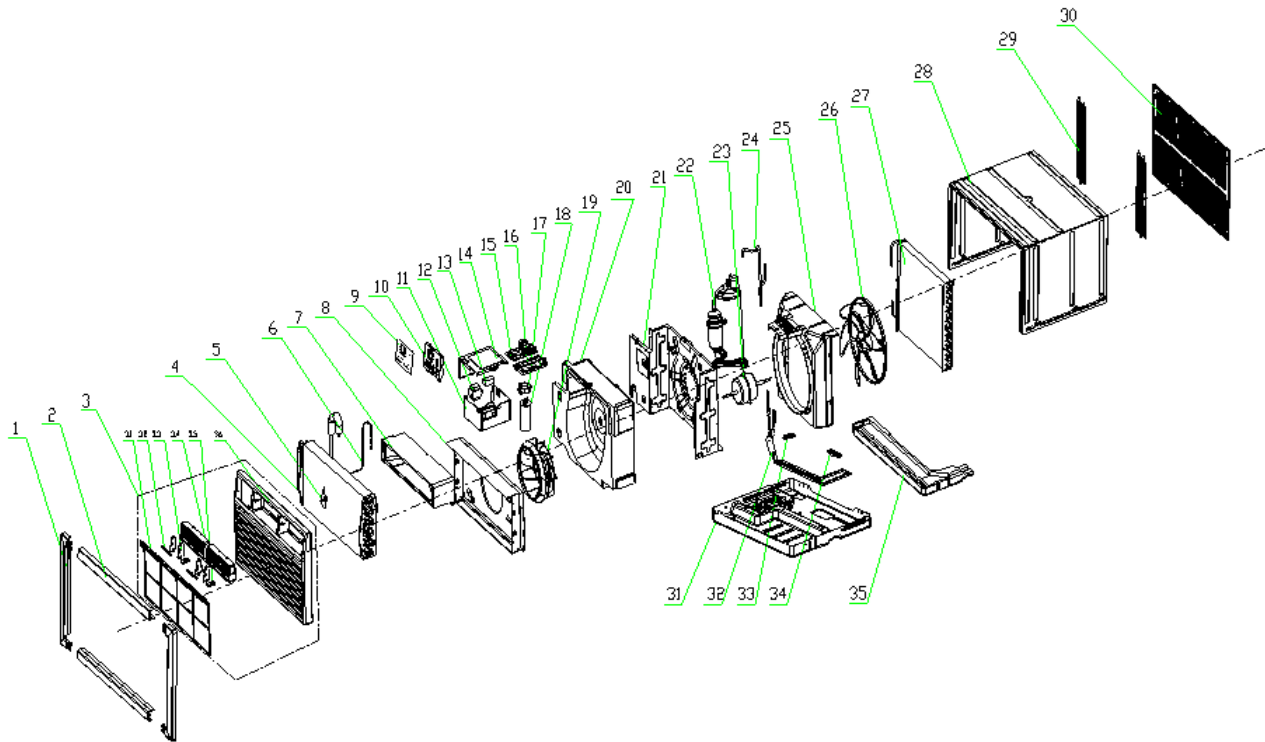

ITEM	PART NUMBER	PART DESCRIPTION	USED ON MODEL	QTY
1	68000055	210738331 - Display decorative piece1	UCT12A30A, UCT14A30A	1
2	68000056	210738332 - Display decorative piece2	UCT12A30A, UCT14A30A	1
3	68000057	210755503 - Front Panel Assembly	UCT12A30A, UCT14A30A	1
3.1	68000058	210755506 - Air Filter	UCT12A30A, UCT14A30A	1
4	68000398	211238079 - Evaporator	UCT12A30A	1
4A	68000407	211244409 - Evaporator	UCT14A30A	1
6	68000399	211238080 - Capillary Assembly	UCT12A30A	1
6A	68000408	211244408 - Capillary Assembly	UCT14A30A	1
7	68000375	210738268A - Outlet foam	UCT12A30A, UCT14A30A	1
8	68000376	210836747 - Front Partition plate	UCT12A30A, UCT14A30A	1
9	68000377	210755615A - Display PCB cover	UCT12A30A, UCT14A30A	1
10	68000132	210738277 - Control Box panel	UCT12A30A, UCT14A30A	1
11	68000378	210836910 - Electrical Box	UCT12A30A, UCT14A30A	1
12	68000062	210901700 - Transformer	UCT12A30A, UCT14A30A	1
13	68000063	1170100034A - Fan Motor Capacitor	UCT12A30A, UCT14A30A	1
14	68000379	210836752 - Electrical Box Cover	UCT12A30A, UCT14A30A	1

# PARTS CATALOG

Unifit Models: UCT12A30A, UCT14A30A

Figure 910

ITEM	PART NUMBER	PART DESCRIPTION	USED ON MODEL	QTY
15	68000395	210901411H - Main pcb	UCT12A30A, UCT14A30A	
16	68000065	210736568 - Main pcb supporter	UCT12A30A, UCT14A30A	1
17	68000380	210738282 - Capacitor Strip	UCT12A30A, UCT14A30A	1
18	68000066	1170100004A - Compressor Capacitor	UCT12A30A	1
18A	68000074	1170100026A - Compressor Capacitor	UCT14A30A	1
19	68000006	210738336 - Centrifugal Fan	UCT12A30A, UCT14A30A	1
20	68000381	210738267A - foam shell	UCT12A30A, UCT14A30A	1
21	68000382	210836909A - Partition plate	UCT12A30A, UCT14A30A	1
22	68000403	211238076 - Compressor	UCT12A30A	1
22A	68000409	211236912 - Compressor	UCT14A30A	1
23	68000068	210901723 - Fan Motor	UCT12A30A, UCT14A30A	1
24	68000401	211236902 - Discharge Pipe	UCT12A30A, UCT14A30A	1
25	68000069	210738266A - Back Partition plate	UCT12A30A, UCT14A30A	1
26	68000070	210738337 - Propeller Fan	UCT12A30A, UCT14A30A	1
27	68000402	211236922B - Condenser	UCT12A30A, UCT14A30A	1
28	68000071	210836745 - Cabinet	UCT12A30A, UCT14A30A	1
29	68000072	210836793 - grille	UCT12A30A, UCT14A30A	1
30	68000048	210836767 - intake and outtake grille	UCT12A30A, UCT14A30A	1
31	68000386	210836781A - Base	UCT12A30A, UCT14A30A	1
32	68000404	211236909 - cold tube	UCT12A30A	1
33	68000405	210738333 - Pipe Cover (two-way)	UCT12A30A, UCT14A30A	1
34	68000406	210738334 - Pipe Cover (three-way)	UCT12A30A, UCT14A30A	1
35	68000051	210738265 - Water drainage pan	UCT12A30A, UCT14A30A	1
-36	68000036	210902158A - Remote Controller	UCT12A30A, UCT14A30A	1
-37	68000397	210901453E - Power Supply Cord	UCT12A30A, UCT14A30A	1
-39	68000054	210901730A - Display PCB	UCT12A30A, UCT14A30A	1
-ITEMS ARE NON- ILLUSTRATED				
*ITEMS ARE NON-STOCKED, WILL NORMALLY REQUIRE 2-3 WEEKS LEAD TIME				

# PARTS CATALOG

Unifit Models: UET08A11A UET10A33A UET12A33A

Figure 911

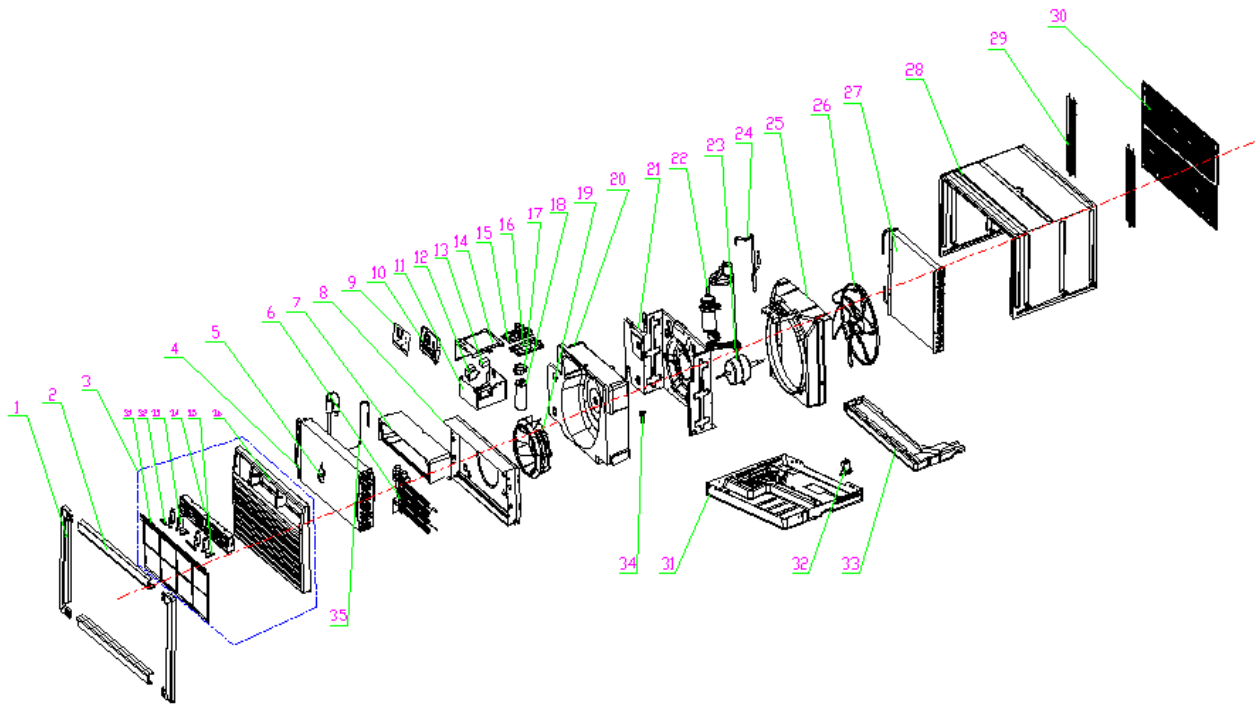

1	68000055	210738331 - Display decorative piece1	UET08A11A, UET10A33A, UET12A33A	1
2	68000056	210738332 - Display decorative piece2	UET08A11A, UET10A33A, UET12A33A	1
3	68000057	210755503 - Front Panel Assembly	UET08A11A, UET10A33A, UET12A33A	1
3.1	68000058	210755506 - Air Filter	UET08A11A, UET10A33A, UET12A33A	1
4	68000373	211244404 - Evaporator	UET08A11A	1
4A	68000391	211238697 - Evaporator	UET10A33A	1
4B	68000398	211238079 - Evaporator	UET12A33A	1
5	#N/A	#N/A	UET08A11A, UET10A33A, UET12A33A	1
6	68000410	210901744 - Heater	UET08A11A	1
6A	68000059	210901743 - Heater	UET10A33A, UET12A33A	1
7	68000375	210738268A - Outlet foam	UET08A11A, UET10A33A, UET12A33A	1
8	68000060	210755614A - Front Partition plate	UET08A11A	1
8A	68000376	210836747 - Front Partition plate	UET10A33A, UET12A33A	1
9	68000060	210755614A - Display PCB cover	UET08A11A, UET10A33A, UET12A33A	1
10	68000132	210738277 - Control Box panel	UET08A11A, UET10A33A, UET12A33A	1
11	68000378	210836910 - Electrical Box	UET08A11A, UET10A33A, UET12A33A	1

# PARTS CATALOG

Unifit Models: UET08A11A UET10A33A UET12A33A

Figure 911

12	68000040	210901721 - Transformer	UET08A11A	1
12A	68000062	210901700 - Transformer	UET10A33A, UET12A33A	1
13	68000041	210901745 - Fan Motor Capacitor	UET08A11A	1
13A	68000046	1170100030A - Fan Motor Capacitor	UET10A33A	1
13B	68000063	1170100034A - Fan Motor Capacitor	UET12A33A	1
14	68000379	210836752 - Electrical Box Cover	UET08A11A, UET10A33A, UET12A33A	1
15	68000042	210901411S - Main pcb	UET08A11A	1
15A	68000064	210901411R - Main pcb	UET10A33A, UET12A33A	1
16	68000065	210736568 - Main pcb supporter	UET08A11A, UET10A33A, UET12A33A	1
17	68000380	210738282 - Capacitor Strip	UET08A11A, UET10A33A, UET12A33A	1
18	68000043	1170100033A - Compressor Capacitor	UET08A11A	1
18A	68000047	1170100023A - Compressor Capacitor	UET10A33A	1
18B	68000066	1170100004A - Compressor Capacitor	UET12A33A	1
19	68000067	210738381 - Centrifugal Fan	UET08A11A, UET10A33A, UET12A33A	1
20	68000411	210738267 - foam shell	UET08A11A, UET10A33A, UET12A33A	1
21	68000382	210836909A - Partition plate	UET08A11A, UET10A33A, UET12A33A	1
22	68000383	211237425 - Compressor	UET08A11A	1
22A	68000396	211231767 - Compressor	UET10A33A	1
22B	68000403	211238076 - Compressor	UET12A33A	1
23	68000044	210901757 - Fan Motor	UET08A11A	1
23A	68000068	210901723 - Fan Motor	UET10A33A, UET12A33A	1
24	68000384	211237435 - Discharge Pipe	UET08A11A	1
24A	68000394	211238696 - Discharge Pipe	UET10A33A	1
24B	68000401	211236902 - Discharge Pipe	UET12A33A	1
25	68000069	210738266A - Back Partition plate	UET08A11A, UET10A33A, UET12A33A	1
26	68000070	210738337 - Propeller Fan	UET08A11A, UET10A33A, UET12A33A	1
27	68000385	211236831B - Condenser	UET08A11A, UET10A33A	1
27A	68000402	211236922B - Condenser	UET12A33A	1
28	68000071	210836745 - Cabinet	UET08A11A, UET10A33A, UET12A33A	1
29	68000072	210836793 - grille	UET08A11A, UET10A33A, UET12A33A	1
30	68000048	210836767 - intake and outtake grille	UET08A11A, UET10A33A, UET12A33A	1
31	68000412	210836781 - Base	UET08A11A, UET10A33A, UET12A33A	1
32	68000050	210901012 - Drainage valve	UET08A11A, UET10A33A, UET12A33A	1
33	68000051	210738265 - Water drainage pan	UET08A11A, UET10A33A, UET12A33A	1

# PARTS CATALOG

Unifit Models: UET08A11A UET10A33A UET12A33A

Figure 911

-34	68000413	210738117 - Sensor supporter (outlet)	UET08A11A, UET10A33A, UET12A33A	1
-35	68000374	211244403 - Capillary Assembly	UET08A11A	1
-35A	68000392	211238698 - Capillary Assembly	UET10A33A	1
-35B	68000399	211238080 - Capillary Assembly	UET12A33A	1
-37	68000045	210901453D - Power Supply Cord	UET08A11A	1
-37A	68000052	210901453B - Power Supply Cord	UET10A33A, UET12A33A	1
-38	68000036	210902158A - Remote Controller	UET08A11A, UET10A33A, UET12A33A	1
-39	68000054	210901730A - Display PCB	UET08A11A, UET10A33A, UET12A33A	1
<p>-ITEMS ARE NON- ILLUSTRATED          *ITEMS ARE NON-STOCKED, WILL NORMALLY REQUIRE 2-3 WEEKS LEAD TIME</p>				



# PARTS CATALOG

Unifit Models: UET14A33A

Figure 912

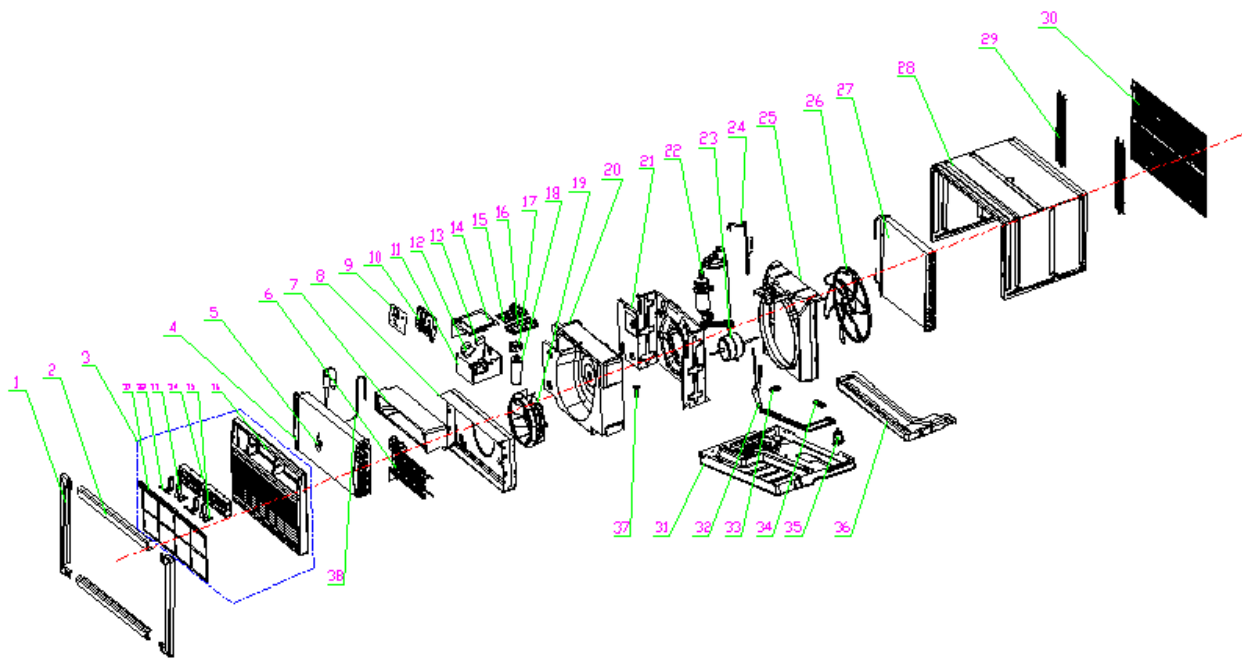

ITEM	PART NUMBER	PART DESCRIPTION	USED ON MODEL	QTY
1	68000055	210738331 - Display decorative piece1	UET14A33A	1
2	68000056	210738332 - Display decorative piece2	UET14A33A	1
3	68000057	210755503 - Front Panel Assembly	UET14A33A	1
3.1	68000058	210755506 - Air Filter	UET14A33A	1
4	68000407	211244409 - Evaporator	UET14A33A	1
5	#N/A	#N/A	UET14A33A	1
6	68000059	210901743 - Heater	UET14A33A	1
7	68000375	210738268A - Outlet foam	UET14A33A	1
8	68000376	210836747 - Front Partition plate	UET14A33A	1
9	68000060	210755614A - Display PCB cover	UET14A33A	1
10	68000132	210738277 - Control Box panel	UET14A33A	1
11	68000378	210836910 - Electrical Box	UET14A33A	1
12	68000062	210901700 - Transformer	UET14A33A	1
13	68000062	210901700 - Fan Motor Capacitor	UET14A33A	1
14	68000379	210836752 - Electrical Box Cover	UET14A33A	1
15	68000064	210901411R - Main pcb	UET14A33A	1
16	68000065	210736568 - Main pcb supporter	UET14A33A	1
17	68000380	210738282 - Capacitor Strip	UET14A33A	1

# PARTS CATALOG

Figure 912

Unifit Models: UET14A33A

ITEM	PART NUMBER	PART DESCRIPTION	USED ON MODEL	QTY
18	68000074	1170100026A - Compressor Capacitor	UET14A33A	1
19	68000067	210738381 - Centrifugal Fan	UET14A33A	1
20	68000411	210738267 - foam shell	UET14A33A	1
21	68000382	210836909A - Partition plate	UET14A33A	1
22	68000409	211236912 - Compressor	UET14A33A	1
23	68000068	210901723 - Fan Motor	UET14A33A	1
24	68000401	211236902 - Discharge Pipe	UET14A33A	1
25	68000069	210738266A - Back Partition plate	UET14A33A	1
26	68000070	210738337 - Propeller Fan	UET14A33A	1
27	68000402	211236922B - Condenser	UET14A33A	1
28	68000071	210836745 - Cabinet	UET14A33A	1
29	68000072	210836793 - grille	UET14A33A	1
30	68000048	210836767 - intake and outtake grille	UET14A33A	1
31	68000412	210836781 - Base	UET14A33A	1
32	68000404	211236909 - cold tube	UET14A33A	1
33	68000405	210738333 - Pipe Cover (two-way)	UET14A33A	1
34	68000406	210738334 - Pipe Cover (three-way)	UET14A33A	1
35	68000050	210901012 - Drainage valve	UET14A33A	1
36	68000051	210738265 - Water drainage pan	UET14A33A	1
37	68000413	210738117 - Sensor supporter (outlet)	UET14A33A	1
38	68000408	211244408 - Capillary Assembly	UET14A33A	1
-40	68000052	210901453B - Power Supply Cord	UET14A33A	1
-41	68000036	210902158A - Remote Controller	UET14A33A	1
-42	68000054	210901730A - Display PCB	UET14A33A	1
-ITEMS ARE NON- ILLUSTRATED				
*ITEMS ARE NON-STOCKED, WILL NORMALLY REQUIRE 2-3 WEEKS LEAD TIME				

# WSE SLEEVE/ EXTERIOR GRILLES

## Available Accessories

### Unifit

#### USC SLEEVE

An existing or new sleeve is required for installation. The Friedrich USC sleeve ships with the accessories needed for installation in new construction, or installation into an existing sleeve.

#### INCLUDED WITH USC SLEEVE

USC wall sleeve ships with weather panels (2) and grille. Sleeve is shown at right with:

1. Painted steel inner panel
2. Painted steel outer panel
3. Painted steel standard grille



USC sleeve



Inner weather panel



Outer weather panel

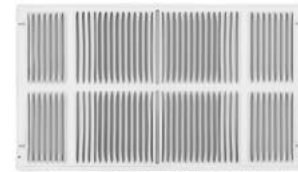

Standard grille

#### OPTIONAL GRILLE

##### ARCHITECTURAL GRILLE-UXAA

Optional extruded brushed aluminum grille.



UXAA, optional architectural grille

#### IMPORTANT:

When installing into an existing sleeve, consult Installation Section of your Installation/Operation Manual to determine whether or not the grille needs to be replaced and/or a baffle adapter (included with chassis) should be used.

#### SLEEVE/ CHASSIS DIMENSIONS

Model	Height	Width	Depth	Depth with Front	Minimum Extension Into Room	Minimum Extension Outside	Thru-the-wall Finished Hole		
							Height	Width	Max. Depth
Uni-Fit *									
USC Sleeve	15 1/2"	25 7/8"	16 3/4"	20 1/2"	-	1/2"	15 3/4"	26 1/8"	16 1/4"
UCT, UET Chassis	14 1/2"	24 1/4"	-	20 5/16"	3 3/4"	-	-	-	-



Friedrich Air Conditioning Company  
10001 Reunion Place, Suite 500  
San Antonio, TX 78216  
800-541-6645  
[www.friedrich.com](http://www.friedrich.com)

## ROOM AIR CONDITIONERS LIMITED WARRANTY

### FIRST YEAR

**ANY PART:** If any part supplied by FRIEDRICH fails because of a defect in workmanship or material within twelve months from date of original purchase, FRIEDRICH will repair the product at no charge, provided room air conditioner is reasonably accessible for service. Any additional labor cost for removing inaccessible units and/or charges for mileage related to travel by a Service Agency that exceeds 25 miles one way will be the responsibility of the owner. This remedy is expressly agreed to be the exclusive remedy within twelve months from the date of the original purchase.

### SECOND THROUGH FIFTH YEAR

**SEALED REFRIGERANT SYSTEM:** If the Sealed Refrigeration System (defined for this purpose as the compressor, condenser coil, evaporator coil, reversing valve, check valve, capillary, filter drier, and all interconnecting tubing) supplied by FRIEDRICH in your Room Air Conditioner fails because of a defect in workmanship or material within sixty months from date of purchase, FRIEDRICH will pay a labor allowance of \$100 and parts necessary to repair the Sealed Refrigeration System; PROVIDED FRIEDRICH will not pay any additional labor charges over the prescribed labor allowance including the cost of diagnosis of the problem, removal, freight charges, and transportation of the air conditioner to and from the Service Agency, and the reinstallation charges associated with repair of the Sealed Refrigeration System. All such cost will be the sole responsibility of the owner. This remedy is expressly agreed to be the exclusive remedy within sixty months from the date of the original purchase.

**APPLICABILITY AND LIMITATIONS:** This warranty is applicable only to units retained within the Fifty States of the U.S.A., District of Columbia, and Canada. This warranty is not applicable to:

1. Air filters, fuses, batteries and the front grille removal tool.
2. Products on which the model and serial numbers have been removed.
3. Products which have defects or damage which results from improper installation, wiring, electrical current characteristics, or maintenance; or caused by accident, misuse or abuse, fire, flood, alterations and/or misapplication of the product and/or units installed in a corrosive atmosphere, default or delay in performance caused by war, government restrictions or restraints, strikes, material shortages beyond the control of FRIEDRICH, or acts of God.

**OBTAINING WARRANTY PERFORMANCE:** Service will be provided by the FRIEDRICH Authorized Dealer or Service Organization in your area. They are listed in the Yellow Pages. If assistance is required in obtaining warranty performance, write to: Room Air Conditioner Service Manager (the Friedrich address is at the top of this warranty) or email [tac@friedrich.com](mailto:tac@friedrich.com).

**LIMITATIONS: THIS WARRANTY IS GIVEN IN LIEU OF ALL OTHER WARRANTIES. Anything in the warranty notwithstanding, ANY IMPLIED WARRANTIES OF FITNESS FOR PARTICULAR PURPOSE AND/OR MERCHANTABILITY SHALL BE LIMITED TO THE DURATION OF THIS EXPRESS WARRANTY. MANUFACTURER EXPRESSLY DISCLAIMS AND EXCLUDES ANY LIABILITY FOR CONSEQUENTIAL OR INCIDENTAL DAMAGE FOR BREACH OF ANY EXPRESSED OR IMPLIED WARRANTY.**

Performance of Friedrich's Warranty obligation is limited to one of the following methods:

1. Repair of the unit
2. A refund to the customer for the prorated value of the unit based upon the remaining warranty period of the unit.
3. Providing a replacement unit of equal value

**The method of fulfillment of the warranty obligation is at the sole discretion of Friedrich Air Conditioning.**

**NOTE:** Some states do not allow limitations on how long an implied warranty lasts, or do not allow the limitation or exclusion of consequential or incidental damages, so the foregoing exclusions and limitations may not apply to you.

**OTHER:** This warranty gives you specific legal rights, and you may also have other rights which vary from state to state.

**PROOF OF PURCHASE:** Owner must provide proof of purchase in order to receive any warranty related services.

All service calls for explaining the operation of this product will be the sole responsibility of the consumer.

All warranty service must be provided by an **Authorized FRIEDRICH Service Agency**, unless authorized by FRIEDRICH prior to repairs being made.

---

**THIS PAGE LEFT INTENTIONALLY BLANK.**

---

## CUSTOMER SATISFACTION and QUALITY ASSURANCE

Friedrich is a conscientious manufacturer, concerned about customer satisfaction, product quality, and controlling warranty costs. As an Authorized Service Provider you play a vital role in these areas. By adhering to the policies and procedures you provide us with vital information on each warranty repair you complete. This information is used to identify product failure trends, initiate corrective action, and improve product quality, thereby further reducing warranty expenses while increasing customer satisfaction levels.

## FRIEDRICH AUTHORIZED PARTS DEPOTS

### **AAA Refrigeration Service**

1322 24th Street, Suite B Kenner,  
Louisiana 70062 504-464-7444  
877-813-7444

### **Alamo Service Company**

1450 North Flores Street San  
Antonio, Texas 78212 210-227-  
2450  
800-328-2450

### **The Gabbert Company**

6868 Ardmore  
Houston, Texas 77054

713-747-4110

800-458-4110

### **Johnstone Supply of Woodside**

27-01 Brooklyn Queens Expway  
Woodside, New York 11377 718-  
545-5464  
800-431-1143

### **Reeve Air Conditioning, Inc.**

2501 South Park Road Hallandale, Florida  
33009 954-962-0252  
800-962-3383



## TECHNICAL SUPPORT CONTACT INFORMATION

Friedrich Air Conditioning Co.  
10001 Reunion Place, Suite 500 • San Antonio, Texas 78216  
1-800-541-6645  
[www.friedrich.com](http://www.friedrich.com)