



INSTALLATION INSTRUCTIONS

EWC V-Series™ Models

This manual must be left with the homeowner for future reference.



This is a safety alert symbol and should never be ignored. When you see this symbol on labels or in manuals, be alert to the potential for personal injury or death.

WARNING

Improper installation, adjustment, alteration, service or maintenance can cause property damage, personal injury or loss of life. Installation and service must be performed by a licensed professional installer (or equivalent), service agency or the gas supplier.

WARNING

Installation and servicing of air conditioning equipment can be hazardous due to internal refrigerant pressure and live electrical components. Only trained and qualified service personnel should install or service this equipment. Installation and service performed by unqualified persons can result in property damage, personal injury or death.

WARNING

For your safety, do not store or use gasoline or other flammable vapors and liquids in the vicinity of this or any other appliance. Such actions could result in property damage, personal injury, or death.

Table of Contents

Unit Dimensions	2
Installation	3
Electrical Connections	4
Operation	5
Maintenance	6
Wiring Diagrams	8

CAUTION

Installation shall be made in accordance with the requirements of the local utility and other authorities having jurisdiction, or with the National Fuel Gas Code, ANSI Z223.1 (latest edition) and the National Electrical Code. Any alteration of internal wiring will void certification and warranties.

WARNING

These units are not approved for mobile home applications. Such use could result in property damage, personal injury, or death.

Manufactured By
Allied Air Enterprises LLC
A Lennox International, Inc. Company
215 Metropolitan Drive
West Columbia, SC 29170



(P) 507390-02

Check that equipment complies with all applicable building codes, laws, and regulations for its intended use prior to installation.

Unit Dimensions

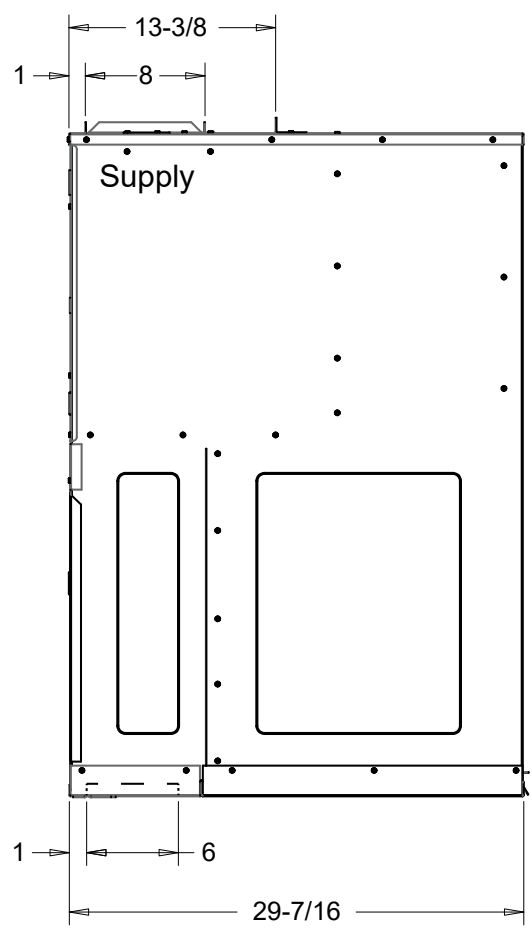
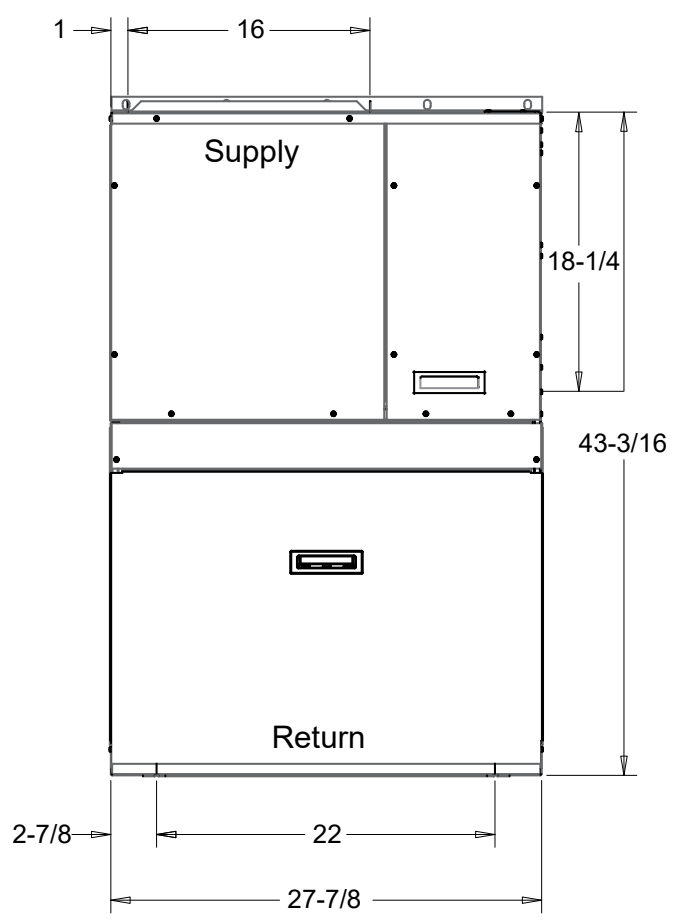
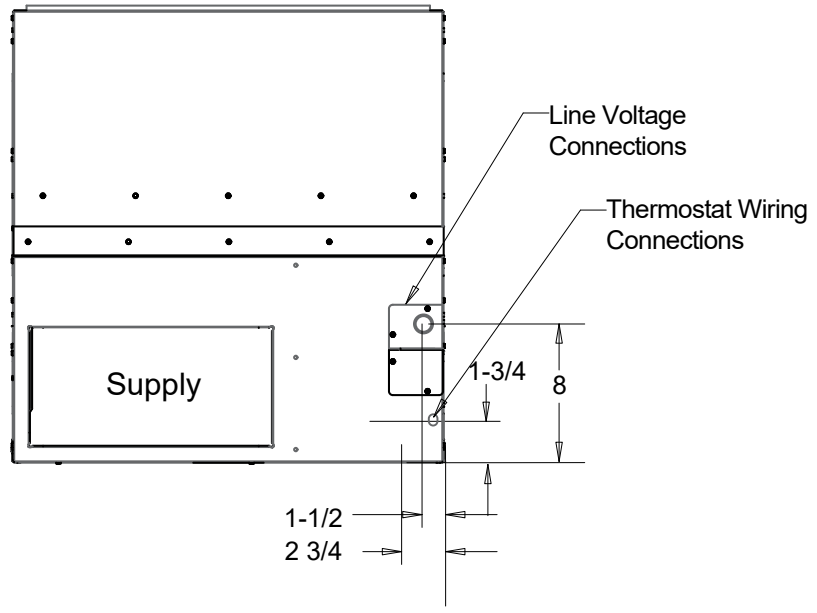

Installation

Installation shall be made in accordance with local utility requirements and any other authorities having jurisdiction.

General

The MagicPak All-In-One™ HVAC system model EWC V-Series™ unit is a self-contained electric heating and cooling unit. This unit has been examined for compliance with Canadian Standards Association CAN/CSA-C22.2 No. 236 (latest edition) and Underwriters Laboratories UL 1995. This unit is also in compliance with AHRI Performance Standard 210/240. Any alterations of internal wiring will void these listings and warranties.

Inspection

This unit is shipped in one package, completely assembled and wired. The drain tubing is in the cooling compartment behind the filter access panel.

If any damage is found, proper notation should be made on the carrier's freight bill. Damage claims should be filed with the carrier at once. Check the rating plate to confirm heating and cooling capacities.

NOTE: Be sure to remove the chassis hold down brackets from the outdoor side of unit before installation. These brackets are located below the louver panels.

Location

The unit is approved for indoor installation only. It must not be installed completely outside. Duct connections as well as service access must be inside the building. The interior portions of the unit may be surrounded by a closet with clearances to combustible material held to 0" at sides, 2" top, and 0" front and plenum. The floor may be combustible.

The grille side of the unit may be flush with, or extend beyond, the face of the exterior wall, but should not be recessed more than 2" from the face of the building and should not be obstructed with trees, landscape materials, or building structure.

If the unit is to be enclosed, provisions should be made allowing access to the indoor side of the unit for changing filters and for inspection. At least 29" of unobstructed space should be provided in front of the indoor side, whether enclosed or not, to permit removal of the cooling chassis should repairs or inspection be required.

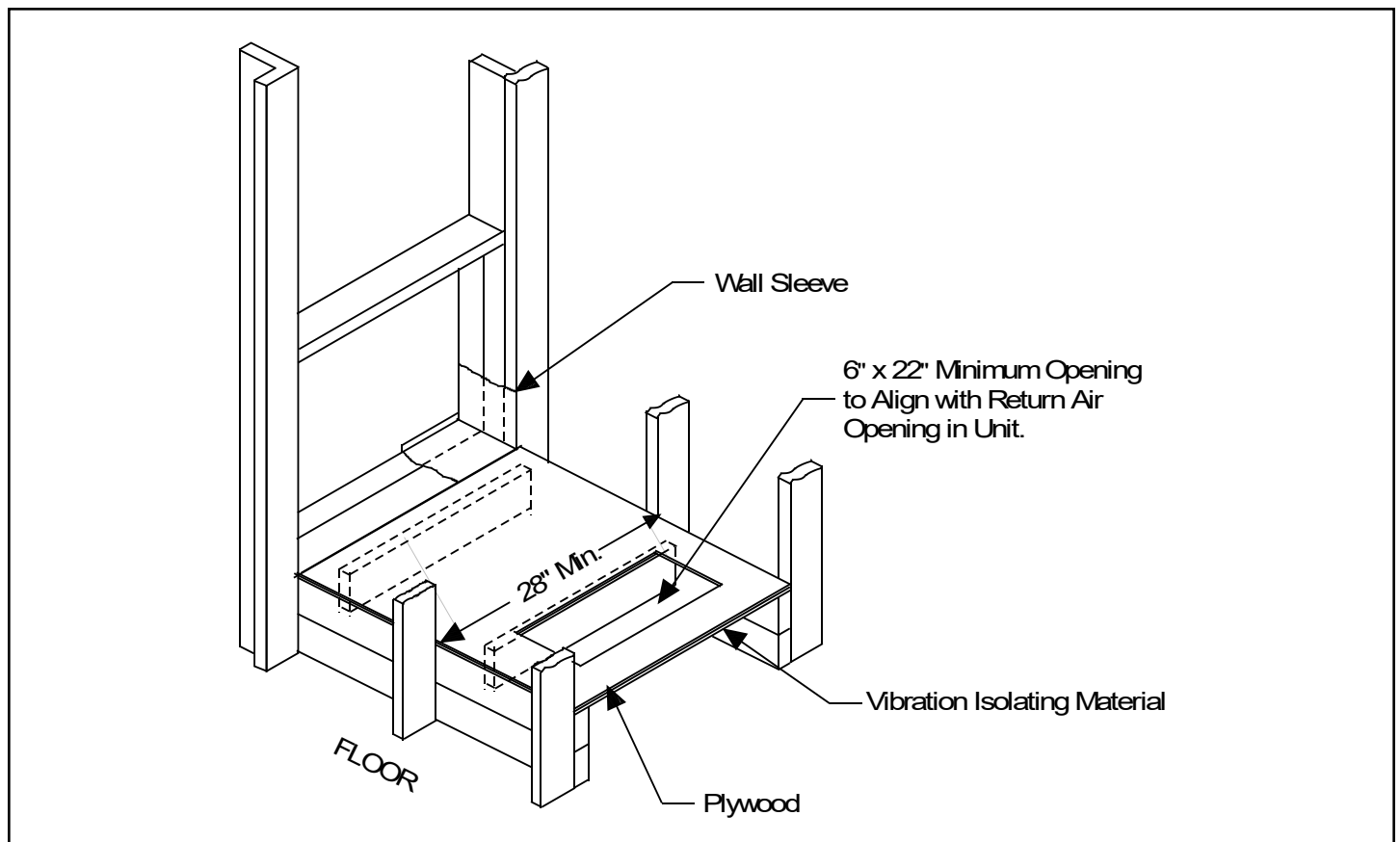

Figure 1. EWC Installation

Installing with a Wall Sleeve

Refer to the installation instructions packed with the wall sleeve and Figure 1 for guidance in assembly and mounting using a wall sleeve.

- Make sure that the gaskets attached to the sleeve are not damaged.
- Seal the space between the wall sleeve and the building opening using non-hardening caulking compound. This seal must be watertight.
- Assure that the unit is completely seated against the gaskets on the wall sleeve.
- Slide the unit into the sleeve. When properly nested, the angle on top of the unit should line up with the top flange of the sleeve and should almost touch. Fasten the unit to the sleeve with five screws furnished with the sleeve.

CAUTION

The sleeve is not intended as the sole support for the unit. An additional support must be provided near the return opening on the unit for adequate support. The use of vibration isolation material between the unit and the support is recommended.

Condensate Drain

To install the condensate line, connect one end of the plastic tube over the 5/8" O.D. fitting in the center of the condensate pan. Connect the other end to the drain tube running to the open trap (see Figure 2).

The drain line should pitch gradually downward at least 1" per 10 feet of horizontal run to the open drain trap.

Be certain that the plastic drain tube has free drainage and is not crimped or flattened at any bend.

Test drainage by pouring water into the drain pan under the evaporator and see that it is removed rapidly through the drain tubing.

The plastic drain connection is provided so that it may be disconnected from the permanent drain tubing in the building without unsoldering in the event it becomes necessary to remove the refrigeration chassis assembly.

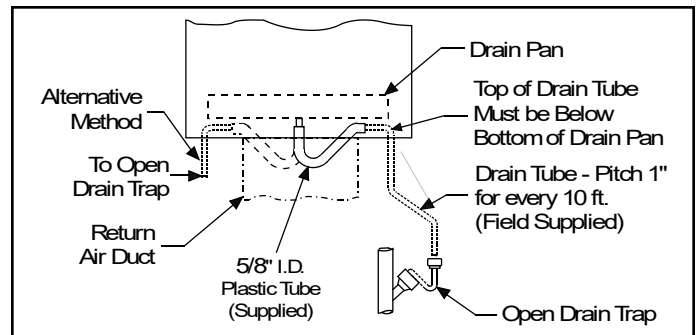

Figure 2. EWC Drain Installation

Electrical Connections

All supply wiring should be done in accordance with the National Electric Code, or with local codes, where they prevail. Any alternation of internal wiring will void certification and warranty.

NOTE: Units are factory wired for a 230-volt power supply. If power supply is 208 volts, it will be necessary to change a wire connection on unit transformer from 240V terminal to 208V terminal as shown on the wiring diagram.

The rating plate indicates the operating voltage, phase, ampacity, and maximum circuit protection. Minimum operating voltage of the 208-230 volt model is 197 volts. Units must never be installed where voltage exceeds 10% of voltage indicated on the rating plate.

Failure of the compressor as a result of operation on improper voltage voids the compressor replacement warranty.

A separate electric line for each circuit should be run through a separate fused disconnect, from the main house panel to the supply terminal block located in the unit.

Thermostat

Install the thermostat according to directions furnished with it. Select a location which will measure true air temperature. The thermostat must be located on an inside wall where it will not be affected by drafts, sunlight, or any other heat producing appliances. Connect the wires to the terminal block on the unit following the wiring diagram attached to the unit.

NOTE: For EWC*30 models, a two-stage thermostat is recommended for reaching highest efficiency and full use of two-stage compressor.

Air Filter

All indoor return air must be filtered before it passes through the evaporator coil. A permanent-type filter is furnished with the unit, located directly in front of evaporator coil. Removing the front panel permits access to the filter.

The filter should be cleaned at least once during each of the heating and cooling seasons and more frequently if unusual dusty conditions are encountered. To clean the

permanent filter, shake the filter to remove excess dirt and/or use a vacuum cleaner. Wash the filter in soap or detergent water and re-install after filter is dry.

The filter supplied need not be oiled after washing.

If an installation is made in which it is more desirable to mount the filter exterior to the unit, in the return duct work or otherwise, the permanent filter supplied can be used or a disposable filter may be used. If a disposable filter is used, the minimum area required is as shown in Table 1.

Cooling Chassis Model Number	Filter Area (sq. in.)
EWC*12	300
EWC*18	480
EWC*24	480
EWC*30	480

Table 1. Minimum Required Surface Area for Disposable Filters

Ductwork

Provide ductwork sufficiently large to handle the larger of the air volumes for heating or cooling provided by this model.

Connect supply duct to top of unit using canvas connection or other flexible connection to prevent noise transmission into the duct system.

To connect the return duct to the unit, use a straight piece of duct 22" wide by 6" deep.

Insert the duct into the opening in the bottom of the unit and flange the duct over the existing flanges around the opening inside the unit. Make sure that all sides of the duct are flanged over to permit removal of the cooling chassis if required. Use a flexible connection to attach the remainder of the return ductwork.

Adjustments

No adjustments are required or should be attempted regarding any of the components of the cooling chassis and electric heating section.

The unit should be checked to see that none of the wiring is loose or missing. The plug-in electrical connector between the cooling chassis and the main control compartment should be checked to make sure that the plug is firmly seated and none of the wires are loose.

Operation

Operation of this unit is automatic and will provide heating or cooling depending on the setting of the thermostat.

Heating

1. Turn on the main power supply.
2. Set the thermostat system switch to "HEAT".
3. Set the thermostat heating scale to the temperature desired.

Cooling

1. Set the thermostat system to "COOL".
2. Set the thermostat cooling scale to the temperature desired.

Blower Operation

Continuous operation of the air handling blower will be obtained if the thermostat fan switch is set to "ON".

With the thermostat switch set to "AUTO", the air handling blower will cycle corresponding with the thermostat cycling.

To Shut Down Unit

For temporary or short periods of shutdown, set the thermostat system switch to "OFF". For a prolonged period of shutdown, set the thermostat system switch to "OFF" and turn off the electrical power supply.

Blower

The unit contains a direct drive, multi-speed blower motor. The proper speed has been set at the factory. Refer to the wiring diagram on the unit for proper wiring connections.

Cooling Chassis

The refrigeration system contained in the cooling chassis normally requires no maintenance since it is a closed self-contained system. Periodic maintenance is limited to:

Cooling Chassis is charged with R410A refrigerant.

- Cleaning the evaporator air filter. Follow the directions noted on the filter and label attached to the access panel.
- Cleaning the condenser coil if covered with foreign material such as lint, leaves, or other obstructions.
- Motors are permanently lubricated and do not normally require re-oiling.

If servicing or major repairs are required, the complete cooling chassis can be removed from the unit. Proceed as follows:

1. Shut off the main power supply.
2. Remove the filter access panel and the panel covering the cooling controls.
3. Remove the drain hose from the drain pan.
4. Disconnect the plug-in electrical connectors. Do not separate the connector by pulling on the wires; instead, grasp the connector handle.
5. Disconnect the two power leads from the contactor. (Leads come from the Grommet in the unit partition.)

6. Remove the screws from the panel directly in front of the blower and remove the panel. Also remove the additional screws located near the top edge of the control panel.
7. Drape power wires and wire harnesses out of cabinet and tape to upper panel.
8. Slide out the chassis, being careful not to damage any seals or parts. Particular care should be taken to insure wiring is not damaged during removal/reinstallation process.

NOTE: *Tubing is not to be used as a handle.*

To re-install the chassis, reverse the procedure outlined above. Be sure that the chassis is inserted as far back as it will go before replacing the screws. Side flanges on the chassis must be engaged with the sealing strips on the unit sides to prevent water and air leakage. Reconnect the plug-in connector, reconnect the power and four leads, and replace both access panels before turning on the main electric power supply.

Heating Section

No maintenance is necessary on the electric heating elements.

Model	Indoor Blower Speed	Unit Voltage (V)	0.1 " w.c.	0.2 " w.c.	0.3 " w.c.	0.4 " w.c.	0.5 " w.c.
EWC0512P12A	TAP 1 (HEAT) *	208 or 230	615	590	570	545	525
	TAP 2 (HEAT)	208 or 230	655	630	610	590	570
	TAP 3 (HEAT)	208 or 230	795	780	760	745	725
	TAP 4 (COOL) †	208 or 230	480	460	440	415	390
	TAP 5 (COOL)	208 or 230	530	505	485	460	430
EWC0712P12A	TAP 1 (HEAT)	208 or 230	615	590	570	545	525
	TAP 2 (HEAT) *	208 or 230	655	630	610	590	570
	TAP 3 (HEAT)	208 or 230	795	780	760	745	725
	TAP 4 (COOL) †	208 or 230	480	460	440	415	390
	TAP 5 (COOL)	208 or 230	530	505	485	460	430
EWC0512P18A EWC0712P18A	TAP 1 (HEAT)	208 or 230	805	785	770	750	730
	TAP 2 (HEAT) *	208 or 230	825	805	785	770	750
	TAP 3 (HEAT)	208 or 230	910	890	875	860	845
	TAP 4 (COOL) †	208 or 230	560	540	520	500	475
	TAP 5 (COOL)	208 or 230	610	580	560	535	505
EWC1012P18A	TAP 1 (HEAT)	208 or 230	805	785	770	750	730
	TAP 2 (HEAT)	208 or 230	825	805	785	770	750
	TAP 3 (HEAT) *	208 or 230	910	890	875	860	845
	TAP 4 (COOL) †	208 or 230	560	540	520	500	475
	TAP 5 (COOL)	208 or 230	610	580	560	535	505
EWC1012P24A	TAP 1 (HEAT)	208 or 230	805	785	770	750	730
	TAP 2 (HEAT)	208 or 230	825	805	785	770	750
	TAP 3 (HEAT) *	208 or 230	910	890	875	860	845
	TAP 4 (COOL) †	208 or 230	770	750	730	710	690
	TAP 5 (COOL)	208 or 230	820	790	770	750	730
EWC1512P24A	TAP 1 (HEAT)	208 or 230	805	785	770	750	730
	TAP 2 (HEAT)	208 or 230	825	805	785	770	750
	TAP 3 (HEAT) *	208 or 230	910	890	875	860	845
	TAP 4 (COOL) †	208 or 230	770	750	730	710	690
	TAP 5 (COOL)	208 or 230	820	790	770	750	730
EWC1012P30A	TAP 1 (HEAT) *	208 or 230	825	805	785	770	750
	TAP 2 (HEAT)	208 or 230	910	890	875	860	845
	TAP 3 (COOL) †	208 or 230	530	510	490	465	440
	TAP 4 (COOL)	208 or 230	570	545	530	505	480
	TAP 5 (COOL) †	208 or 230	950	920	900	885	865
EWC1512P30A	TAP 1 (HEAT)	208 or 230	825	805	785	770	750
	TAP 2 (HEAT) *	208 or 230	910	890	875	860	845
	TAP 3 (COOL) †	208 or 230	530	510	490	465	440
	TAP 4 (COOL)	208 or 230	570	545	530	505	480
	TAP 5 (COOL) †	208 or 230	950	920	900	885	865

NOTE: EWC**30A models shipped with Low and High stage Cooling taps connected for use of the two-stage system.

* As shipped speed for Heating operation

† As shipped speed for Cooling operation

Table 2. Supply Airflow Performance (SCFM) as a Function of External Static Pressure

Wiring Diagrams

MODEL	COOLING SPEED	HEATING SPEED
EWC0512P12A	TAP #4	TAP #1
EWC0712P12A	TAP #4	TAP #2
EWC0512P18A	TAP #4	TAP #2
EWC0712P18A	TAP #4	TAP #2
EWC1012P18A	TAP #4	TAP #3

CIRCUITS ENERGIZED

OPERATING MODE	CIRCUIT
HEATING	R-W
COOLING	R-G-Y
FAN	R-G

LINE VOLTAGE-FACTORY
 LINE VOLTAGE-FIELD
 LOW VOLTAGE-FACTORY
 LOW VOLTAGE-FIELD

NOTE:
IF ANY OF THE ORIGINAL WIRES ARE REPLACED THE SAME SIZE AND TYPE WIRE MUST BE USED.

208/230V-1Ø-60Hz
POWER SUPPLY
COPPER CONDUCTORS ONLY.

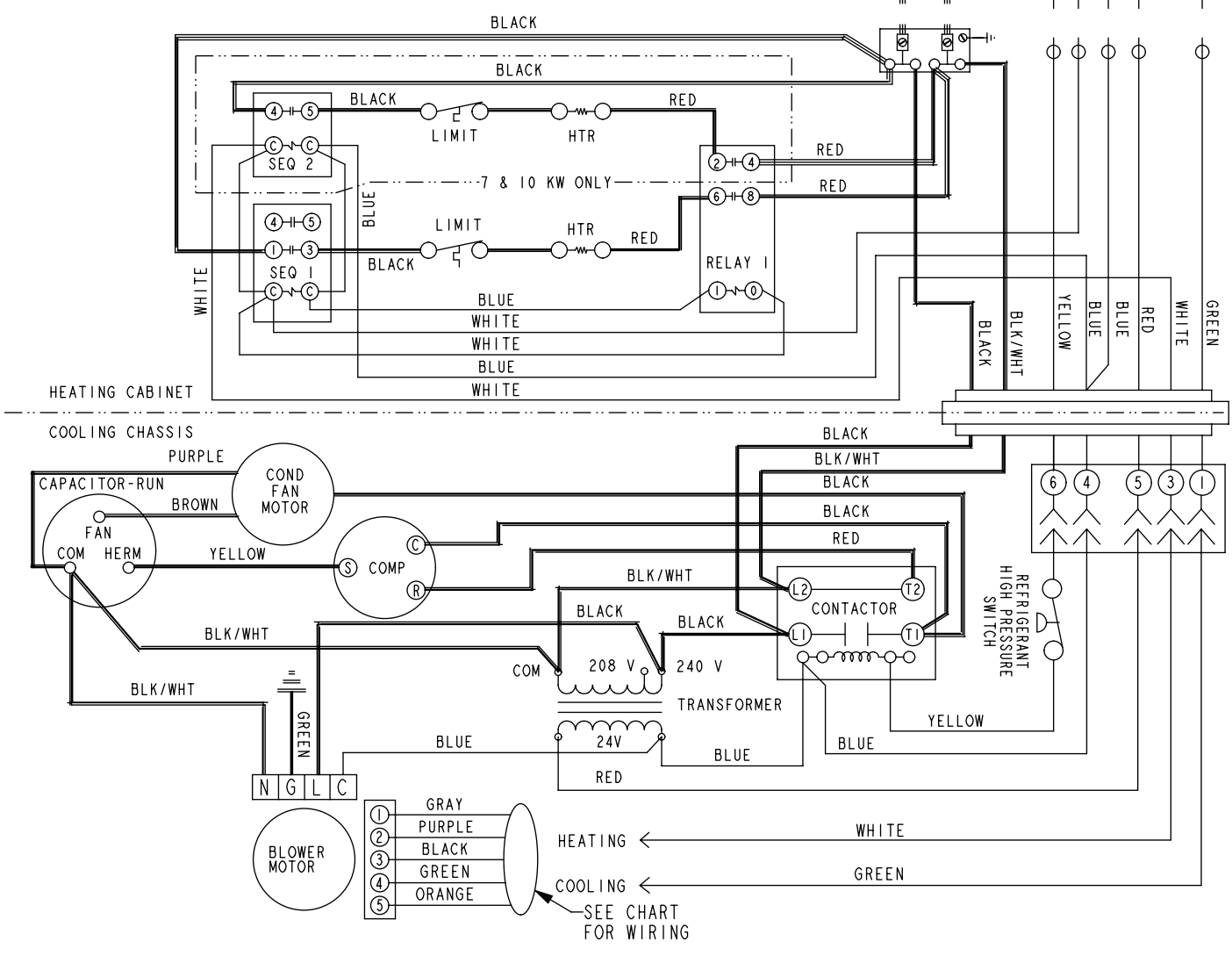
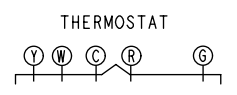

Figure 3. Wiring Diagram - EWC*12P12A, EWC*12P18A

MODEL	COOLING SPEED	HEATING SPEED
EWC1012P24A	TAP #4	TAP #3

——— LINE VOLTAGE-FACORY
 ■ ■ ■ LINE VOLTAGE-FIELD
 ——— LOW VOLTAGE-FACORY
 - - - LOW VOLTAGE-FIELD

NOTE:
 IF ANY OF THE ORIGINAL WIRES ARE REPLACED THE SAME SIZE AND TYPE WIRE MUST BE USED.

CIRCUITS ENERGIZED
 OPERATING MODE
 HEATING R-W
 COOLING R-G-Y
 FAN R-G

208/230V-1 ϕ -60Hz
 POWER SUPPLY
 COPPER CONDUCTORS ONLY.

THERMOSTAT
 (Y) (W) (C) (R) (G)

L1 L2

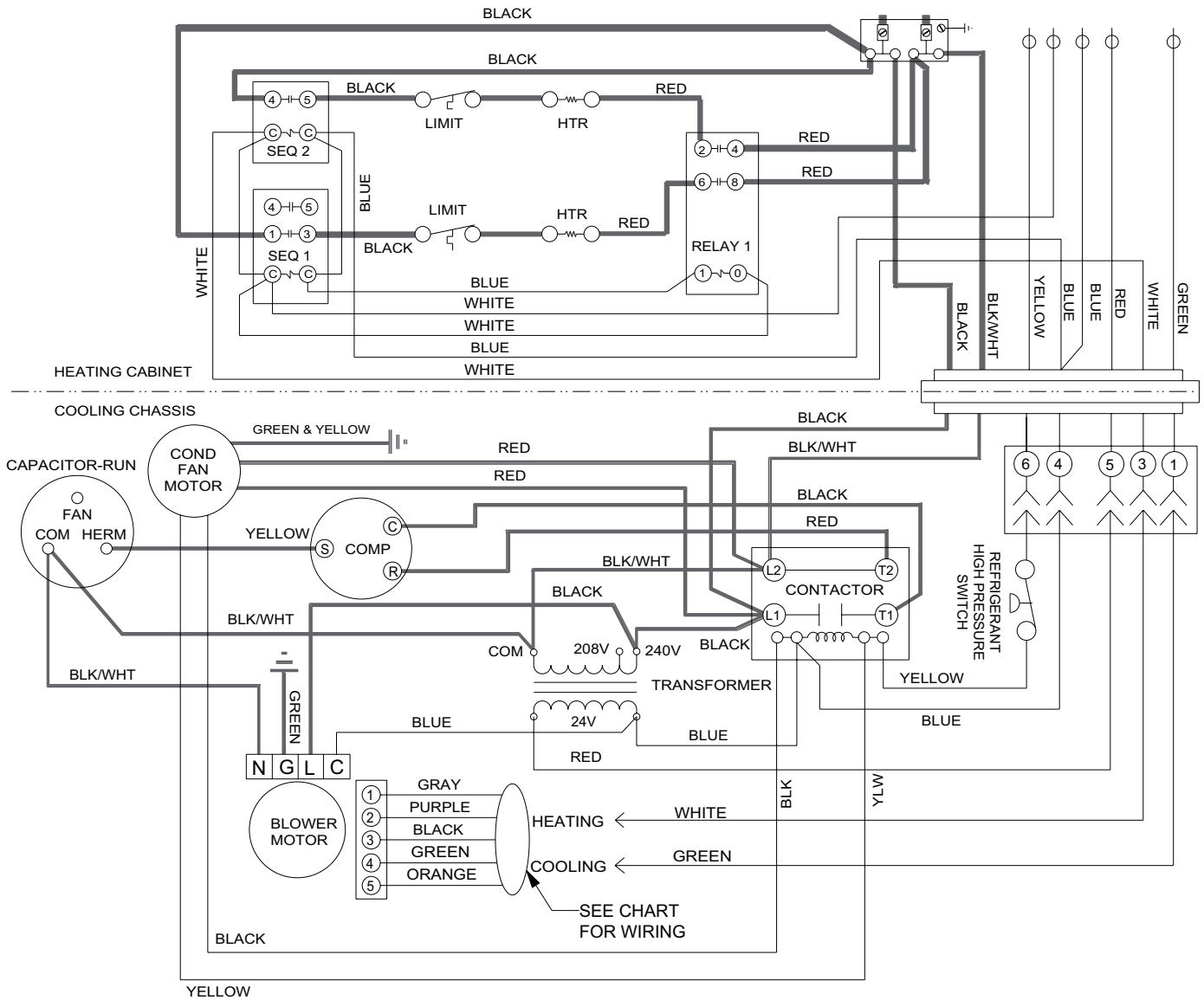

Figure 4. Wiring Diagram - EWC1012P24A

MODEL	COOLING SPEED	HEATING SPEED
EWC1512P24A	TAP #4	TAP #3

CIRCUITS ENERGIZED

OPERATING MODE	CIRCUIT
HEATING	R-W
COOLING	R-G-Y
FAN	R-G

— LINE VOLTAGE-FACTORY
 - - - LINE VOLTAGE-FIELD
 — LOW VOLTAGE-FACTORY
 - - - LOW VOLTAGE-FIELD

NOTE:
IF ANY OF THE ORIGINAL WIRES ARE REPLACED THE SAME SIZE AND TYPE WIRE MUST BE USED.

208/230V-1 ϕ -60Hz
POWER SUPPLY
COPPER CONDUCTORS
ONLY.

THERMOSTAT

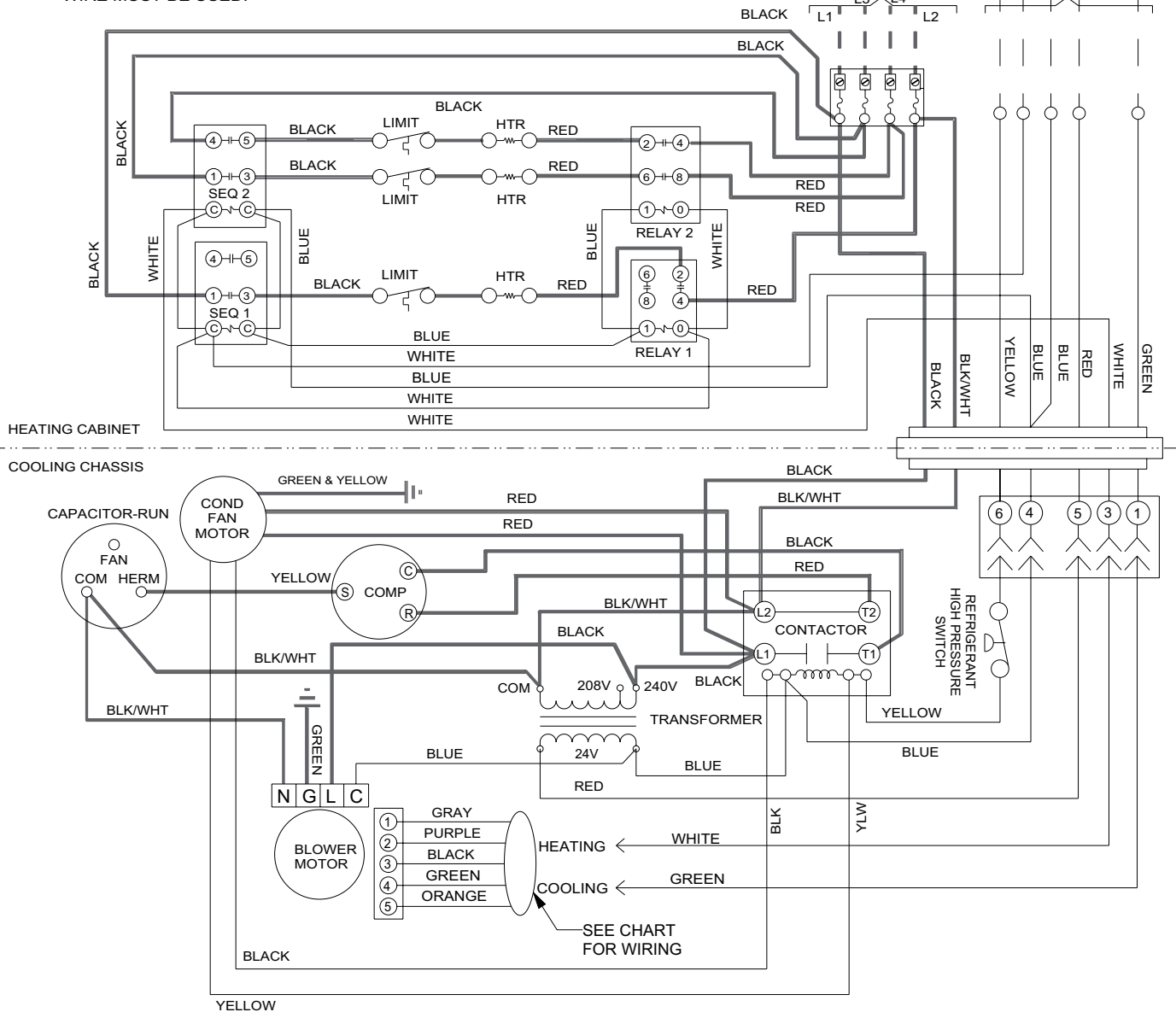

Figure 5. Wiring Diagram - EWC1512P24A

MODEL	LOW COOLING SPEED	HIGH COOLING SPEED	HEATING SPEED
EWC1012P30A	TAP #3	TAP #5	TAP #2

CIRCUITS ENERGIZED	
OPERATING MODE	CIRCUIT
HEATING	R-W
COOLING - LOW STAGE	R-G-Y
COOLING - HIGH STAGE	R-G-Y-Y2
FAN	R-G

===== LINE VOLTAGE-FACTORY
 == == == LINE VOLTAGE-FIELD
 ----- LOW VOLTAGE-FACTORY
 - - - - - LOW VOLTAGE-FIELD

NOTE:
 IF ANY OF THE ORIGINAL WIRES ARE
 REPLACED THE SAME SIZE AND TYPE
 WIRE MUST BE USED.

208/230V-1Ø-60Hz
 POWER SUPPLY
 COPPER CONDUCTORS
 ONLY.

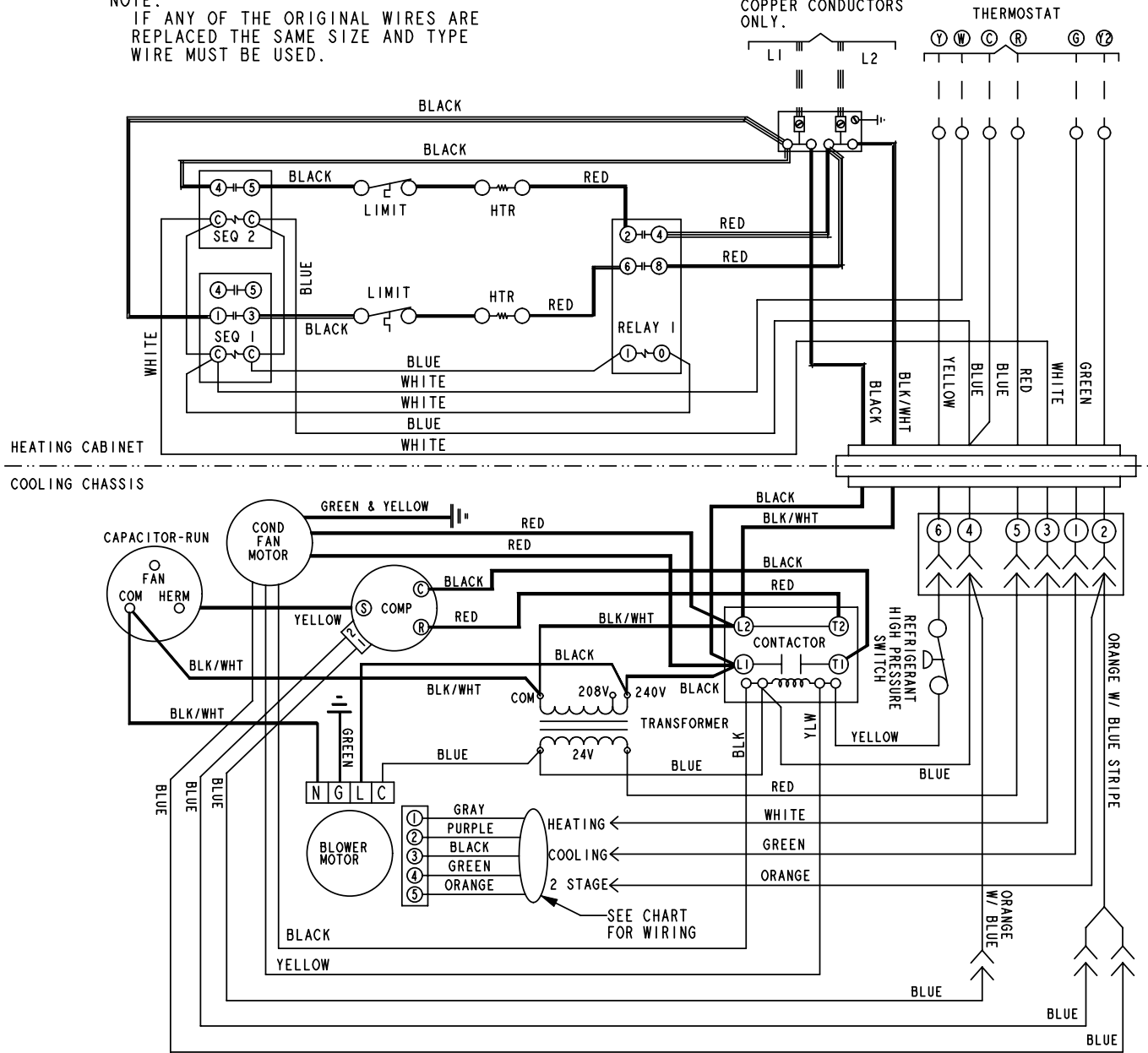

Figure 6. Wiring Diagram - EWC1012P30A

MODEL	LOW COOLING SPEED	HIGH COOLING SPEED	HEATING SPEED
EWC1512P30A	TAP #3	TAP #5	TAP #2

CIRCUITS ENERGIZED

OPERATING MODE	CIRCUIT
HEATING	R-W
COOLING - LOW STAGE	R-G-Y
COOLING - HIGH STAGE	R-G-Y-Y2
FAN	R-G

==== LINE VOLTAGE-FACTORY
 == == == LINE VOLTAGE-FIELD
 --- --- LOW VOLTAGE-FACTORY
 - - - - LOW VOLTAGE-FIELD

NOTE:
 IF ANY OF THE ORIGINAL WIRES ARE REPLACED THE SAME SIZE AND TYPE WIRE MUST BE USED.

208/230V-1Ø-60Hz
 POWER SUPPLY
 COPPER CONDUCTORS ONLY.

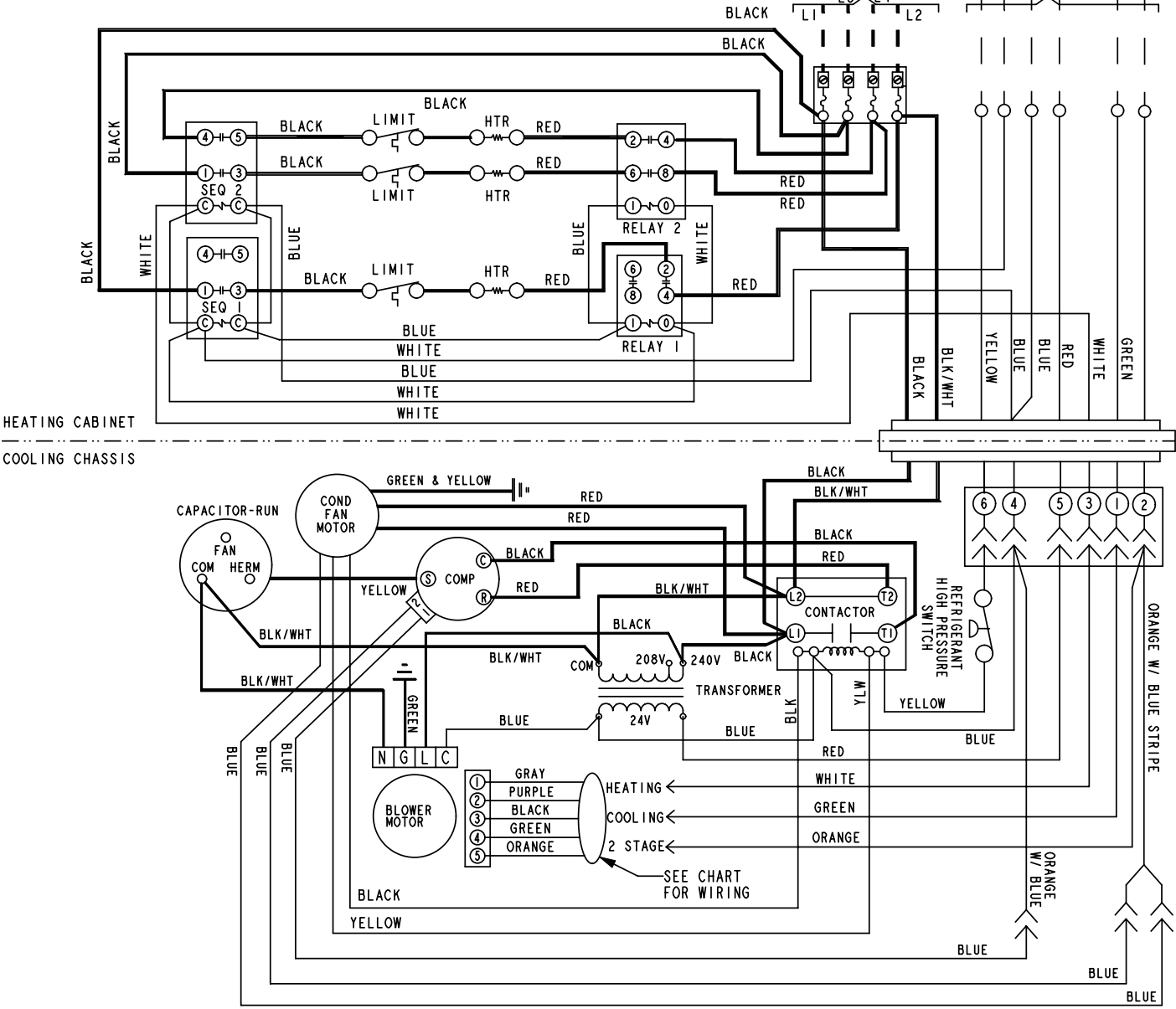

Figure 7. Wiring Diagram - EWC1512P30A