

SAMSUNG

SINGLE Technical Data Book

**Low Ambient Line up for America
(R410A, Cooling Only)**

Model : CNH**4DB (AC***BN4DCH/AA), CNH**HDB (AC***BNHDCH/AA),
CNH**ADB (AC***BNADCH/AA), CNH**TDB (AC***BNTDCH/AA), CXC**SCB (AC***BXSCCC/AA)

History

Version	Modification	Date	Remark
Ver.1.0	Released 2021 CAC TDB for North America (Low Ambient Line up)	21. 12. 24	
Ver.1.1	Modified the Net Weight Spec of the Wind-Free 4Way Cassette	22. 02. 07	

Features & Benefits

CAC - World-class energy efficiency

Maintain optimal comfort and control with energy and cost-efficient technologies

Featuring a suite of energy-optimizing technologies, Samsung CAC Single delivers top-class energy efficiency to support business in saving costs and the environment.

Quick, efficient heating and cooling

Smart inverter technology offers powerful, quick cooling and heating with minimal electricity consumption, which means real cost savings and less energy waste.

Up to 50 percent less energy use

After reaching changes its operation mode to economical. By avoiding inefficient and frequent switching on and off of the compressor, the digital inverter saves up to 50 percent in energy consumption compared to non-inverter air conditioners.

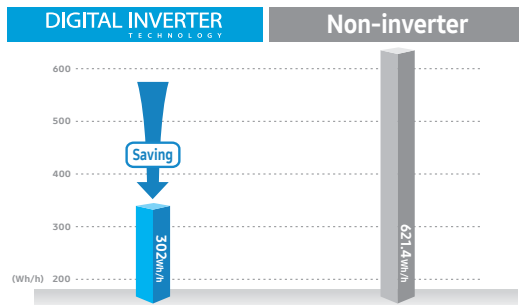

Wind-Free Cooling with Micro holes

- The Wind-Free Air conditioner pushes air out through 15,000 micro holes in the panel, producing a dispersed and gentle flow of air actually defined as “still air” and the key here is all of those holes create a still, cooled air flow that infiltrates the room gently and softly.
- ※ Still Air condition : According to ASHRAE, If velocity of wind is lower than 0.15m/s, People can not detect wind. And they define that condition is “Still Air”

No Direct Wind & Cold Draft



[Comparison of Room Temp.]

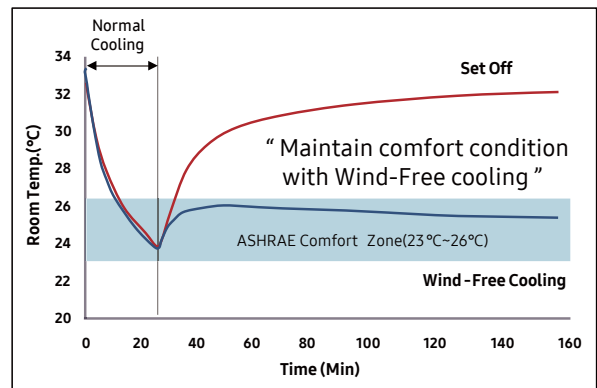

※ Internal Test (14.0kW Model @ 122m²)

Features & Benefits

CAC Single - Superior performance

Stabilize the atmosphere with broad temperature allowance and control

Samsung is dedicated to supporting comfortable living and working environments based on the strength of its technologies. With a single unit, CAC Single delivers reliable comfort and control over multiple areas to ensure a pleasant atmosphere in any climate.

Wide temperature performance

No matter how extreme the temperature, the high-performing CAC Single can handle the condition—without the need for an additional unit. Featuring a wide temperature allowance, it can cool in heat of up to 50 and provide warmth in the freezing cold of -20°C to ensure a constant and comfortable home environment.

Ideal comfort in minutes

The CAC Single digital inverter air conditioner works at maximum capacity at startup. As soon as the temperature reaches the desired or set temperature, CAC Single performs fine adjustments to cope with any changes. This means less temperature fluctuation and ideal comfort in a matter of minutes.

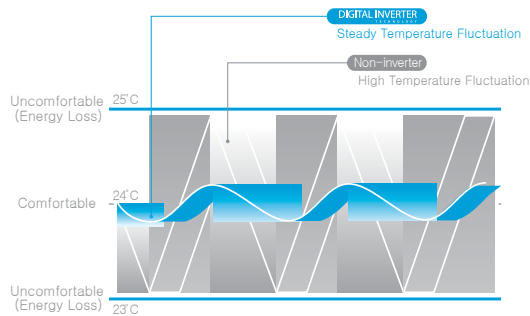

Versatile piping installation

CAC Single outdoor units offer a selection of pipe directions. The internal pipe connection ports allow four different pipe directions, supporting a neater, more organized-looking unit upon installation.



Nomenclature

US Code

Model Name

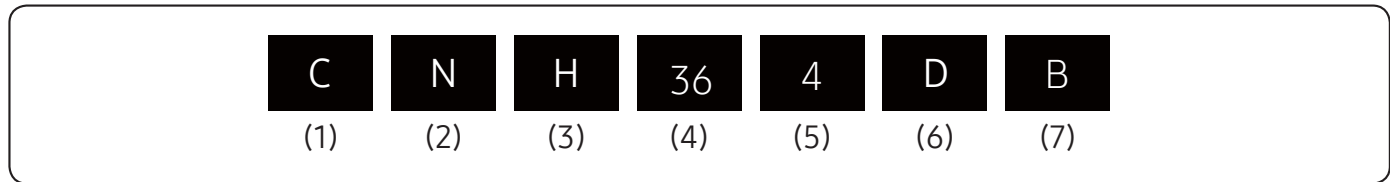

(1) Classification

C	CAC
---	-----

(2) Product Type

N	Indoor Unit
X	Outdoor Unit

(3) Mode

A	Universal
C	Cooling Only
H	Heat Pump

(4) Capacity

	X1,000 Btu/h (2 digits)
--	-------------------------

(5-1) Product Notation (Indoor Unit)

1	1 Way Cassette / Wind-Free 1Way Cassette
N	4 Way Cassette (600x600) Wind-Free 4 Way Cassette (600x600)
4	4 Way Cassette, 360 Cassette Wind-Free 4 Way Cassette
L	LSP Duct
H	HSP Duct
C	Ceiling
J	Console
A	AR9500 (Wall Mounted)
T	MAX4 (Wall Mounted)
Z	Multi-position AHU

(5-2) Feature1 (Outdoor Unit)

A	Inv+Side+General Temp
S	Inv+Side+Low Temp
Q	Inv+Side+Tropical Temp
F	Inv+Top+Tropical Temp

(6) Feature

F	Flagship
S	Standard
D	Deluxe
P	Premium
C	Deluxe + Low Temp.

(7) Version

B	2022
---	------

Nomenclature

Indoor Unit

Model Name

AC	036	B	N	4	D	C	H	/	AA
(1)	(2)	(3)	(4)	(5)	(6)	(7)	(8)		Buyer

(1) Classification

AC	CAC
----	-----

(2) Capacity

X1,000 Btu/h (3 digits)

(3) Version

B	2022
---	------

(4) Product Type

N	Indoor Unit
X	Outdoor Unit

(5) Product Notation

1	1 Way Cassette
N	4 Way Cassette (600x600) Wind-Free 4 Way Cassette (600x600)
4	4 Way Cassette, 360 Cassette Wind-Free 4 Way Cassette
L	LSP Duct
H	HSP Duct
C	Ceiling
J	Console
A	AR9500 (Wall Mounted)
T	MAX4 (Wall Mounted)
Z	Multi-position AHU

(6) Feature

F	Flagship
S	Standard
D	Deluxe
P	Premium

(7) Rating Voltage

C	1Φ, 208-230V,60Hz
---	-------------------

(8) Mode

C	Cooling Only
H	Heat Pump

Nomenclature

Outdoor Unit

Model Name

AC	036	B	X	S	C	C	C	/	AA
(1)	(2)	(3)	(4)	(5)	(6)	(7)	(8)		Buyer

(1) Classification

AC	CAC
----	-----

(2) Capacity

x 1000 Btu/h (3 digits)

(3) Version

B	2022
---	------

(4) Product Type

N	Indoor Unit (NASA)
X	Outdoor Unit (NASA)

(5) Feature1

A	Inv+Side+General Temp
S	Inv+Side+Low Temp
Q	Inv+Side+Tropical Temp
F	Inv+Top+Tropical Temp

(6) Feature2

F	Flagship
S	Standard
D	Deluxe
P	Premium
C	Deluxe + Low Temp.

(7) Rating Voltage









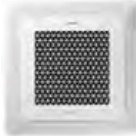

C	1Φ, 208~230V, 60Hz
H	3Φ, 400V, 60Hz

(8) Mode





H	Heat Pump(R410A)
C	Cooling Only(R410A)
E	Heat Pump(R22)
D	Cooling Only(R22)

Line-up

Indoor unit

Model	Capacity (kBtu/h)			
	18	24	30	36
Wind-Free 4Way Cassette				
Duct S				
Wall Mounted Type				

Outdoor Unit

Model	Capacity (kBtu/h)			
	18	24	30	36
1Phase				

Contents

Wind-Free 4Way Cassette	10
Duct S	26
Wall Mounted Type	49
Outdoor Units	68
Installation	85

Wind-Free 4Way Cassette

1. Specification	12
2. Summary Table	16
3. Capacity Table	17
4. Dimensional Drawing	19
5. Center of Gravity	21
6. Electrical Wiring Diagram	22
7. Sound Data	23
8. Temperature and air flow distribution	25

Features & Benefits

Wind-Free 4Way Cassette

Stage a beautiful yet comfortable environment

With its newly improved design, Wind-Free 4Way Cassette supports a clean, aesthetically appealing atmosphere and adds a sense of sophistication to work and living spaces. Not only is this unit attractively designed, but it also uses advanced technologies to optimize comfort in any environment.



Wind-Free 4Way Cassette - Stylishly clean design

Aesthetic panel and display

Wind-Free 4Way Cassette offers two different pattern designs for the panel. The simple display design with rounded corners adds a chic sophistication to the interior.



The Samsung Wind-Free 4Way Cassette indoor air conditioning system delivers polish, comfort and efficiency with features such as:

- **Stylishly clean design.** Add panache to interior spaces with a choice of clean, streamlined panel patterns in a lightweight build.
- **Robust operation.** Control the atmosphere perfectly with an advanced design for superior airflow and cooling/heating performance.
- **Low maintenance and simple installation.** Ease installation and minimize maintenance with a detachable, no-drip design.

Neat and clean design

The indoor Wind-Free 4Way Cassette boasts a smart design that promotes a neat and clean look. The completely hermetic blade structure keeps the indoor unit clean by preventing dust or other foreign substances from entering it. The internal parts of the indoor unit are also out of sight when the blade is shut, thus improving the unit's appearance.

Lightweight build

The Samsung Wind-Free 4Way Cassette indoor unit is now lighter in weight at 17 kg. It is one of the lightest indoor units in the industry, about 40 percent lighter than conventional products.

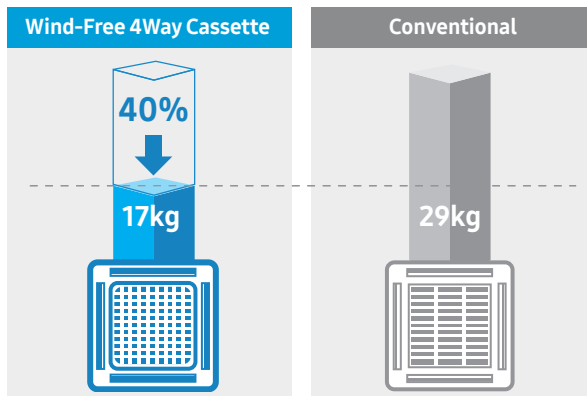

*Based on 10kW

1. Specification

Wind-Free 4Way Cassette

Model Name		Indoor Unit		AC018BN4DCH/AA		AC024BN4DCH/AA			
US Code		Indoor Unit		CNH184DB		CNH244DB			
		Outdoor Unit		CXC18SCB		CXC24SCB			
System	Mode			-	Cooling Only		Cooling Only		
	Performance	Capacity (Min/Std/Max)	Cooling	kW	1.17/5.28/6.45		1.76/7.03/8.79		
				Btu/h	4,000 / 18,000 / 22,000		6,000 / 24,000 / 30,000		
				US RT	0.33/1.50/1.83		0.50/2.00/2.50		
			Heating	kW	-		-		
				Btu/h	-		-		
				US RT	-		-		
	Power	Power Input (Min/Std/Max)	Cooling	kW	0.24 / 1.49 / 2.20		0.30 / 2.14 / 3.69		
			Heating	-	-		-		
		Current Input (Min/Std/Max)	Cooling	A	1.50 / 6.82 / 9.70		1.90 / 9.59 / 16.20		
			Heating	-	-		-		
		Current	MCA	A	12.2		18.8		
			MFA	A	15		25		
	Efficiency	EER	Cooling	-	3.54		3.29		
			Cooling(US)	(Btu/h)/W	12.10		11.20		
		COP	Heating	W/W	-		-		
		SEER	-	22.0		21.0			
		HSPF	-	-		-			
	Pipe Connections	Liquid Pipe		Type	Flare		Flare		
				Φ, mm(inch)	6.35 (1/4)		6.35 (1/4)		
		Gas Pipe		Type	Flare		Flare		
				Φ, mm(inch)	12.7 (1/2)		15.88 (5/8)		
		Heat Insulation			-	Both liquid and gas pipes		Both liquid and gas pipes	
		Pipe Length (ODU-IDU)	Standard	Max.	m (ft)	7.5 (24.6)		7.5 (24.6)	
				Elevation	m (ft)	30 (98.4)		50 (164.0)	
	Chargeless			m (ft)	20 (65.6)		30 (98.4)		
				m (ft)	7.5 (24.6)		7.5 (24.6)		
	Wiring Connections	Communication	Min.	mm ²	0.75		0.75		
Remark			-	F1,F2		F1,F2			
Refrigerant	Type		-	R410A		R410A			
	Factory Charging		kg	1.3		2			
Option Code	Standard		-	0143FF-1950C6-2F343B-370020		0143FF-1950C6-27484F-370020			
	Install		-	020010-100001-200000-300000		020010-100001-200000-300000			
Indoor Unit	Power Supply			Φ,#,V,Hz	1,2,208-230,60		1,2,208-230,60		
	Heat Exchanger	Type		-	Fin & Tube		Fin & Tube		
		Material	Fin	-	Al		Al		
			Tube	-	Cu		Cu		
		Fin Treatment			-	Green Hydrophile		Green Hydrophile	
	Fan	Type		-	Turbo		Turbo		
		Quantity		EA	1		1		
		Air Flow Rate	H/M/L	m ³ /min	24.0/21.0/18.0		24.0/21.0/18.0		
				ft ³ /min	848/742/636		848/742/636		
				l/s	400/350/300		400/350/300		
	External Static Pressure	Min/Std/Max	In Wg	-		-			
	Fan Motor	Type		-	BLDC		BLDC		
		Output		W x n	65 x 1		65 x 1		
	Drain	Drain Pipe		Φ, mm	OD26.67		OD26.67		
	Sound	Sound Pressure Level	H/M/L	dB(A)	36/33/30		36/33/30		
				Sound Power Level	dB(A)	53		53	
	External Dimension	Net Weight		kg(lbs)	15.9(35.1)		16.0(35.3)		
		Gross Weight		kg(lbs)	19.4(42.8)		19.5(43.0)		
		Net Dimensions (WxHxD)		mm	840 x 246 x 840		840 x 246 x 840		
				inch	33.07 x 9.69 x 33.07		33.07 x 9.69 x 33.07		
		Gross Dimensions (WxHxD)		mm	898 x 316 x 898		898 x 316 x 898		
	inch			35.35 x 12.44 x 35.35		35.35 x 12.44 x 35.35			

1. Specification

Wind-Free 4Way Cassette

Model Name		Indoor Unit		AC018BN4DCH/AA	AC024BN4DCH/AA	
		Outdoor Unit		AC018BXSCCC/AA	AC024BXSCCC/AA	
US Code		Indoor Unit		CNH184DB	CNH244DB	
		Outdoor Unit		CXC18SCB	CXC24SCB	
Indoor Unit	Casing	Material	-	Polypropylene	Polypropylene	
		Model Name	-	PC4NUFMUN	PC4NUFMUN	
	Panel	Type	-	Wind-Free Type	Wind-Free Type	
		Material	-	HIPS	HIPS	
		Color	-	DA White	DA White	
		Net Weight	kg(lbs)	6.3 (13.9)	6.3 (13.9)	
		Gross Weight	kg(lbs)	8.7 (19.2)	8.7 (19.2)	
		Net Dimensions (WxHxD)	mm	950 x 64 x 950	950 x 64 x 950	
			inch	37.4 x 2.5 x 37.4	37.4 x 2.5 x 37.4	
	Gross Dimensions (WxHxD)	mm	1,010 x 117 x 1,000	1,010 x 117 x 1,000		
		inch	39.8 x 4.6 x 39.4	39.8 x 4.6 x 39.4		
	Control System	Infrared remote control	-	AR-EH04U	AR-EH04U	
		Wired remote control	-	MWR-WG00UN / MWR-SH11UN	MWR-WG00UN / MWR-SH11UN	
	Drain Pump	Drain Pump	-	Included	Included	
Max.lifting Height / Displacement		in / gal/h	29-5/16 6.34gal/h	29-5/16 6.34gal/h		
Additional Accessories	Air Filter	-	Removable / Washable	Removable / Washable		
Outdoor Unit	Power Supply		Φ,#,V,Hz	1,2,208-230,60	1,2,208-230,60	
	Heat Exchanger	Type	-	Fin & Tube	Fin & Tube	
		Material	Fin	-	Al	Al
			Tube	-	Cu	Cu
	Fin Treatment		-	Anti-Corrosion	Anti-Corrosion	
	Compressor	Model	-	UG9TK3150FE4SG	UG4T200FUAE4SG	
		Type	-	Twin BLDC	Twin BLDC	
		Output	kW	1.42	1.79	
		Oil	Type	-	POE	POE
	Initial Charge		cc (fl oz)	500	650	
	Fan	Type	-	Propeller	Propeller	
		Discharge direction		-	Front	Front
		Quantity		EA	1	1
		Air Flow Rate	H/M/L	m ³ /min	40	51
ft ³ /min				1,413	1,801	
l/s	667			850		
Fan Motor	Type	-	BLDC	BLDC		
	Output	W x n	125 x 1	125 x 1		
Sound	Sound Pressure Level	Cooling	dB(A)	48	50	
		Heating	dB(A)	-	-	
	Sound Power Level		dB(A)	62	65	
External Dimension	Net Weight		kg(lbs)	40.5 (89.3)	52.5 (115.7)	
	Gross Weight		kg(lbs)	43.5 (95.9)	56.5 (124.6)	
	Net Dimensions (WxHxD)	mm	880 x 638 x 310	880 x 798 x 310		
		inch	34.64 x 25.12 x 12.20	34.64 x 31.42 x 12.20		
	Gross Dimensions (WxHxD)	mm	1,023 x 881 x 413	1,023 x 881 x 413		
inch		40.28 x 28.74 x 16.26	40.28 x 34.69 x 16.26			
Casing	Material	Body	-	Steel	Steel	
Operating Temp. Range	Cooling	°C (°F)	-40~50 (-40~122)	-40~50 (-40~122)		
	Heating	°C (°F)	-	-		

NOTE

- Specification may be subject to change without prior notice.
 - 1) Performances are based on the following test conditions.
 - Cooling : Indoor temperature : 80°F(26.7°C) DB, 67°F(19.4°C) WB, Outdoor temperature : 95°F(35°C) DB, 75°F(23.9°C) WB
 - Heating : Indoor temperature : 70°F(21.1°C) DB, 60°F(15.6°C) WB, Outdoor temperature : 47°F(8.3°C) DB, 43°F(6.1°C) WB
 - Equivalent refrigerant piping length 5m(16.4ft), Level differences : 0m(0ft)
 - 2) Select wire size based on the value of MCA
 - 3) Sound pressure level is obtained in an anechoic room.
 - Sound pressure level is a relative value, depending on the distance and acoustic environment.
 - Sound pressure level may differ depending on operation condition.
 - dBA = A-weighted sound pressure level / Reference acoustic pressure 0 dB = 20uPa
 - 4) Sound power level is an absolute value that a sound source generates.
 - dBA = A-weighted sound power level
 - Reference power : 1pW / Measured according to ISO 3741
 - 5) These products contain R410A which is fluorinated greenhouse gas.

1. Specification

Wind-Free 4Way Cassette

Model Name		Indoor Unit		AC030BN4DCH/AA		AC036BN4DCH/AA		
US Code		Indoor Unit		CNH304DB		CNH364DB		
		Outdoor Unit		CXC30SCB		CXC36SCB		
System	Mode			-	Cooling Only		Cooling Only	
	Performance	Capacity (Min/Std/Max)	Cooling	kW	2.64/8.79/10.55		2.93/10.55/11.72	
				Btu/h	9,000 / 30,000 / 36,000		10,000 / 36,000 / 40,000	
				US RT	0.75/2.50/3.00		0.83/3.00/3.33	
			Heating	kW	-		-	
				Btu/h	-		-	
				US RT	-		-	
	Power	Power Input (Min/Std/Max)	Cooling	kW	0.61 / 2.73 / 4.60		0.70 / 3.60 / 4.80	
			Heating	kW	-		-	
		Current Input (Min/Std/Max)	Cooling	A	3.10 / 12.11 / 20.20		3.60 / 15.81 / 21.10	
			Heating	A	-		-	
		Current	MCA	A	22.2		22.2	
			MFA	A	30		30	
	Efficiency	EER	Cooling	-	3.22		2.93	
			Cooling(US)	(Btu/h)/W	11.00		10.00	
		COP	Heating	W/W	-		-	
		SEER	-	-	21.0		18.5	
		HSPF	-	-	-		-	
	Pipe Connections	Liquid Pipe		Type	Flare		Flare	
				Φ, mm(inch)	9.52 (3/8)		9.52 (3/8)	
		Gas Pipe		Type	Flare		Flare	
				Φ, mm(inch)	15.88 (5/8)		15.88 (5/8)	
		Heat Insulation		-	Both liquid and gas pipes		Both liquid and gas pipes	
		Pipe Length (ODU-IDU)	Standard	Max.	m (ft)	7.5 (24.6)		7.5 (24.6)
Elevation				m (ft)	50 (164.0)		50 (164.0)	
Chargeless	m (ft)			30 (98.4)		30 (98.4)		
Chargeless	m (ft)			7.5 (24.6)		7.5 (24.6)		
Wiring Connections	Communication	Min.	mm ²	0.75		0.75		
		Remark	-	F1,F2		F1,F2		
Refrigerant	Type		-	R410A		R410A		
	Factory Charging		kg	2.4		2.4		
Option Code	Standard		-	0143FF-195418-275A5E-370040		0143FF-19546A-276975-370040		
	Install		-	020010-100001-200000-300000		020010-100001-200000-300000		
Indoor Unit	Power Supply			Φ,#,V,Hz	1,2,208-230,60		1,2,208-230,60	
	Heat Exchanger	Type		-	Fin & Tube		Fin & Tube	
		Material	Fin	-	Al		Al	
			Tube	-	Cu		Cu	
		Fin Treatment		-	Green Hydrophile		Green Hydrophile	
	Fan	Type		-	Turbo(3D)		Turbo(3D)	
		Quantity		EA	1		1	
		Air Flow Rate	H/M/L	m ³ /min	28.2/23.6/17.8		34.2/25.8/19.0	
				ft ³ /min	996/833/629		1208/911/671	
				l/s	470/393/297		570/430/317	
	External Static Pressure	Min/Std/Max	In Wg	-		-		
	Fan Motor	Type		-	BLDC		BLDC	
		Output		W x n	97 x 1		97 x 1	
	Drain	Drain Pipe		Φ, mm	OD26.67		OD26.67	
	Sound	Sound Pressure Level	H/M/L	dB(A)	37/34/30		43/38/33	
				dB(A)	53		59	
	External Dimension	Net Weight		kg(lbs)	19.0(41.9)		21.2(46.7)	
		Gross Weight		kg(lbs)	22.5(49.6)		24.8(54.7)	
		Net Dimensions (WxHxD)		mm	840 x 288 x 840		840 x 288 x 840	
				inch	33.07 x 11.34 x 33.07		33.07 x 11.34 x 33.07	
Gross Dimensions (WxHxD)		mm	898 x 357 x 898		898 x 357 x 898			
		inch	35.35 x 14.06 x 35.35		35.35 x 14.06 x 35.35			

1. Specification

Wind-Free 4Way Cassette

Model Name		Indoor Unit		AC030BN4DCH/AA	AC036BN4DCH/AA		
		Outdoor Unit		AC030BXSCCC/AA	AC036BXSCCC/AA		
US Code		Indoor Unit		CNH304DB	CNH364DB		
		Outdoor Unit		CXC30SCB	CXC36SCB		
Indoor Unit	Casing	Material		-	Polypropylene		
		Model Name		-	PC4NUFMUN		
	Panel	Type		-	Wind-Free Type	Wind-Free Type	
		Material		-	HIPS	HIPS	
		Color		-	DA White	DA White	
		Net Weight		kg(lbs)	6.3 (13.9)	6.3 (13.9)	
		Gross Weight		kg(lbs)	8.7 (19.2)	8.7 (19.2)	
		Net Dimensions (WxHxD)		mm	950 x 64 x 950	950 x 64 x 950	
				inch	37.4 x 2.5 x 37.4	37.4 x 2.5 x 37.4	
	Gross Dimensions (WxHxD)		mm	1,010 x 117 x 1,000	1,010 x 117 x 1,000		
			inch	39.8 x 4.6 x 39.4	39.8 x 4.6 x 39.4		
	Control System	Infrared remote control		-	AR-EH04U	AR-EH04U	
		Wired remote control		-	MWR-WG00UN / MWR-SH11UN	MWR-WG00UN / MWR-SH11UN	
Drain Pump	Drain Pump		-	Included	Included		
	Max.lifting Height / Displacement		in / gal/h	29-5/16 6.34gal/h	29-5/16 6.34gal/h		
Additional Accessories	Air Filter		-	Removable / Washable	Removable / Washable		
Outdoor Unit	Power Supply		Φ,#,V,Hz	1,2,208-230,60	1,2,208-230,60		
	Heat Exchanger	Type		-	Fin & Tube	Fin & Tube	
		Material	Fin	-	Al	Al	
			Tube	-	Cu	Cu	
		Fin Treatment		-	Anti-Corrosion	Anti-Corrosion	
	Compressor	Model		-	UG8T300FUBJUSG	UG8T300FUBJUSG	
		Type		-	Twin BLDC	Twin BLDC	
		Output		kW	2.82	2.82	
		Oil	Type		-	POE	POE
			Initial Charge		cc (fl oz)	1200	1200
	Fan	Type		-	Propeller	Propeller	
		Discharge direction		-	Front	Front	
		Quantity		EA	1	1	
		Air Flow Rate	H/M/L	m ³ /min	78	78	
				ft ³ /min	2,755	2,755	
	l/s			1,300	1,300		
	Fan Motor	Type		-	BLDC	BLDC	
		Output		W x n	125 x 1	125 x 1	
	Sound	Sound Pressure Level	Cooling	dB(A)	52	54	
			Heating	dB(A)	-	-	
		Sound Power Level		dB(A)	67	69	
	External Dimension	Net Weight		kg(lbs)	71.0 (156.5)	71.0 (156.5)	
		Gross Weight		kg(lbs)	76.0 (167.6)	76.0 (167.6)	
		Net Dimensions (WxHxD)		mm	940 x 998 x 330	940 x 998 x 330	
				inch	37.01 x 39.29 x 12.99	37.01 x 39.29 x 12.99	
		Gross Dimensions (WxHxD)		mm	995 x 1,096 x 426	995 x 1,096 x 426	
	inch			37.17 x 43.15 x 16.77	37.17 x 43.15 x 16.77		
Casing	Material	Body		-	Steel		
				-	Steel		
Operating Temp. Range	Cooling		°C (°F)	-40~50 (-40~122)	-40~50 (-40~122)		
	Heating		°C (°F)	-	-		

NOTE

- Specification may be subject to change without prior notice.
 - 1) Performances are based on the following test conditions.
 - Cooling : Indoor temperature : 80°F(26.7°C) DB, 67°F(19.4°C) WB, Outdoor temperature : 95°F(35°C) DB, 75°F(23.9°C) WB
 - Heating : Indoor temperature : 70°F(21.1°C) DB, 60°F(15.6°C) WB, Outdoor temperature : 47°F(8.3°C) DB, 43°F(6.1°C) WB
 - Equivalent refrigerant piping length 5m(16.4ft), Level differences : 0m(0ft)
 - 2) Select wire size based on the value of MCA
 - 3) Sound pressure level is obtained in an anechoic room.
 - Sound pressure level is a relative value, depending on the distance and acoustic environment.
 - Sound pressure level may differ depending on operation condition.
 - dBA = A-weighted sound pressure level / Reference acoustic pressure 0 dB = 20uPa
 - 4) Sound power level is an absolute value that a sound source generates.
 - dBA = A-weighted sound power level
 - Reference power : 1pW / Measured according to ISO 3741
 - 5) These products contain R410A which is fluorinated greenhouse gas.

2. Summary Table

Wind-Free 4Way Cassette

Performance Characteristics

Model Code	Net Weight (lbs)	Capacity		Fan Speed	Airflow (Cooling/Heating) (CFM)	Sound Pressure Level (dBA)	Sound Power Level (dBA)	
		Cooling (Btu/h)	Heating (Btu/h)					
CNH184DB (AC018BN4DCH/AA)	35.1	Max.	22,000	-	High	848 / -	36	53
		Std.	18,000	-	Mid	742 / -	33	-
		Min.	4,000	-	Low	636 / -	30	-
CNH244DB (AC024BN4DCH/AA)	35.3	Max.	30,000	-	High	848 / -	36	53
		Std.	24,000	-	Mid	742 / -	33	-
		Min.	6,000	-	Low	636 / -	30	-
CNH304DB (AC030BN4DCH/AA)	41.9	Max.	36,000	-	High	996 / -	37	53
		Std.	30,000	-	Mid	833 / -	34	-
		Min.	9,000	-	Low	629 / -	30	-
CNH364DB (AC036BN4DCH/AA)	46.7	Max.	40,000	-	High	1,208 / -	43	59
		Std.	36,000	-	Mid	911 / -	38	-
		Min.	10,000	-	Low	671 / -	33	-

NOTE

- Sound data is based on cooling operation.

Electric Characteristics

Model		Outdoor Unit				Input Current (Amperes)			Power Supply		
Indoor Unit	Outdoor Unit	Rated	Voltage range		Outdoor Unit		Indoor Unit	Total	MCA(A)	MOP(A)	
		Hz	Volts	Min.	Max	Cooling					Heating
CNH184DB (AC018BN4DCH/AA)	CXC18SCB (AC018BXSCCC/AA)	60	208 to 230	187	253	11.33	-	0.79	12.12	12.2	15
CNH244DB (AC024BN4DCH/AA)	CXC24SCB (AC024BXSCCC/AA)	60	208 to 230	187	253	17.95	-	0.79	18.74	18.8	25
CNH304DB (AC030BN4DCH/AA)	CXC30SCB (AC030BXSCCC/AA)	60	208 to 230	187	253	21.33	-	0.79	22.12	22.2	30
CNH364DB (AC036BN4DCH/AA)	CXC36SCB (AC036BXSCCC/AA)	60	208 to 230	187	253	21.33	-	0.79	22.12	22.2	30

NOTE

- MCA : Minimum circuit amperes
- MOP: Maximum Overcurrent Protective Device
- Select wire size based on the value of MCA

3. Capacity Table

Wind-Free 4Way Cassette

(1) CNH184DB (AC018BN4DCH/AA) + CXC18SCB (AC018BXSCCC/AA)

Cooling

TC : Total Capacity, SHC : Sensible Heat Capacity, PI : Power Input

Outdoor Temp. (°F, DB)	Indoor Temperature (°F, DB / WB)																				
	68 / 57			72 / 61			77 / 64			80 / 67			82 / 70			86 / 72			90 / 75		
	TC	SHC	PI	TC	SHC	PI	TC	SHC	PI	TC	SHC	PI	TC	SHC	PI	TC	SHC	PI	TC	SHC	PI
	MBH	MBH	kW	MBH	MBH	kW	MBH	MBH	kW	MBH	MBH	kW	MBH	MBH	kW	MBH	MBH	kW	MBH	MBH	kW
-40	23.1	16.7	1.26	24.3	17.2	1.29	25.3	17.7	1.31	26.1	18.3	1.34	26.6	18.1	1.35	28.0	17.9	1.37	29.4	17.5	1.40
0	19.9	14.4	1.40	21.0	14.8	1.43	21.8	15.3	1.46	22.5	15.8	1.49	23.0	15.6	1.50	24.1	15.4	1.52	25.3	15.1	1.55
70	21.5	15.5	1.54	22.6	16.0	1.57	23.6	16.5	1.61	24.3	17.0	1.64	24.8	16.8	1.66	26.0	16.7	1.67	27.3	16.3	1.71
95	15.9	11.5	1.40	16.8	11.9	1.43	17.5	12.2	1.46	18.0	12.6	1.49	18.4	12.5	1.50	19.3	12.3	1.52	20.2	12.1	1.55
115	16.7	13.8	2.10	17.6	14.2	2.15	18.3	14.7	2.19	18.9	15.1	2.24	19.3	15.0	2.26	20.2	14.8	2.28	21.3	14.5	2.33
122	11.9	11.1	1.61	12.6	11.4	1.65	13.1	11.8	1.68	13.5	12.2	1.71	13.8	12.0	1.73	14.5	11.9	1.75	15.2	11.7	1.78

(2) CNH244DB (AC024BN4DCH/AA) + CXC24SCB (AC024BXSCCC/AA)

Cooling

TC : Total Capacity, SHC : Sensible Heat Capacity, PI : Power Input

Outdoor Temp. (°F, DB)	Indoor Temperature (°F, DB / WB)																				
	68 / 57			72 / 61			77 / 64			80 / 67			82 / 70			86 / 72			90 / 75		
	TC	SHC	PI	TC	SHC	PI	TC	SHC	PI	TC	SHC	PI	TC	SHC	PI	TC	SHC	PI	TC	SHC	PI
	MBH	MBH	kW	MBH	MBH	kW	MBH	MBH	kW	MBH	MBH	kW	MBH	MBH	kW	MBH	MBH	kW	MBH	MBH	kW
-40	25.5	19.7	1.61	26.8	20.3	1.64	27.9	21.0	1.68	28.8	21.6	1.71	29.4	21.4	1.73	30.8	21.2	1.75	32.4	20.7	1.78
0	23.4	18.1	1.41	24.6	18.6	1.44	25.6	19.2	1.47	26.4	19.8	1.50	26.9	19.6	1.51	28.3	19.4	1.53	29.7	19.0	1.56
70	28.7	22.2	1.91	30.2	22.9	1.95	31.4	23.6	1.99	32.4	24.3	2.03	33.0	24.1	2.05	34.7	23.8	2.07	36.4	23.3	2.12
95	21.2	15.3	2.01	22.3	15.8	2.06	23.3	16.3	2.10	24.0	16.8	2.14	24.5	16.6	2.16	25.7	16.5	2.18	27.0	16.1	2.23
115	20.2	16.6	2.62	21.2	17.2	2.67	22.1	17.7	2.73	22.8	18.2	2.78	23.3	18.1	2.81	24.4	17.9	2.84	25.6	17.5	2.89
122	18.0	15.8	2.52	19.0	16.3	2.57	19.8	16.8	2.62	20.4	17.3	2.68	20.8	17.2	2.70	21.8	17.0	2.73	22.9	16.7	2.78

NOTE

- The performance table shows the average value of each conditions.

3. Capacity Table

Wind-Free 4Way Cassette

(3) CNH304DB (AC030BN4DCH/AA) + CXC30SCB (AC030BXSCCC/AA)

Cooling

TC : Total Capacity, SHC : Sensible Heat Capacity, PI : Power Input

Outdoor Temp. (°F, DB)	Indoor Temperature (°F, DB / WB)																				
	68 / 57			72 / 61			77 / 64			80 / 67			82 / 70			86 / 72			90 / 75		
	TC	SHC	PI	TC	SHC	PI	TC	SHC	PI	TC	SHC	PI	TC	SHC	PI	TC	SHC	PI	TC	SHC	PI
	MBH	MBH	kW	MBH	MBH	kW	MBH	MBH	kW	MBH	MBH	kW	MBH	MBH	kW	MBH	MBH	kW	MBH	MBH	kW
-40	30.5	23.6	2.83	32.1	24.3	2.88	33.5	25.1	2.94	34.5	25.9	3.00	35.2	25.6	3.03	36.9	25.4	3.06	38.8	24.9	3.12
0	31.8	24.6	2.83	33.5	25.4	2.88	34.9	26.2	2.94	36.0	27.0	3.00	36.7	26.7	3.03	38.6	26.5	3.06	40.5	25.9	3.12
70	33.2	25.7	2.44	34.9	26.5	2.49	36.4	27.3	2.54	37.5	28.1	2.59	38.3	27.8	2.62	40.2	27.6	2.65	42.2	27.0	2.70
95	26.5	20.5	2.57	27.9	21.2	2.62	29.1	21.8	2.68	30.0	22.5	2.73	30.6	22.3	2.76	32.1	22.1	2.78	33.7	21.6	2.84
115	22.6	20.9	2.83	23.7	21.6	2.88	24.7	22.3	2.94	25.5	23.0	3.00	26.0	22.7	3.03	27.3	22.5	3.06	28.7	22.0	3.12
122	19.9	18.5	2.70	21.0	19.1	2.75	21.8	19.6	2.81	22.5	20.3	2.87	23.0	20.0	2.90	24.1	19.8	2.92	25.3	19.5	2.98

(4) CNH364DB (AC036BN4DCH/AA) + CXC36SCB (AC036BXSCCC/AA)

Cooling

TC : Total Capacity, SHC : Sensible Heat Capacity, PI : Power Input

Outdoor Temp. (°F, DB)	Indoor Temperature (°F, DB / WB)																				
	68 / 57			72 / 61			77 / 64			80 / 67			82 / 70			86 / 72			90 / 75		
	TC	SHC	PI	TC	SHC	PI	TC	SHC	PI	TC	SHC	PI	TC	SHC	PI	TC	SHC	PI	TC	SHC	PI
	MBH	MBH	kW	MBH	MBH	kW	MBH	MBH	kW	MBH	MBH	kW	MBH	MBH	kW	MBH	MBH	kW	MBH	MBH	kW
-40	36.6	28.3	3.73	38.6	29.2	3.80	40.2	30.1	3.88	41.4	31.1	3.96	42.2	30.7	4.00	44.3	30.4	4.04	46.6	29.8	4.12
0	38.2	29.6	3.73	40.2	30.5	3.80	41.9	31.4	3.88	43.2	32.4	3.96	44.1	32.1	4.00	46.3	31.8	4.04	48.6	31.1	4.12
70	39.8	30.8	3.22	41.9	31.8	3.28	43.7	32.7	3.35	45.0	33.8	3.42	45.9	33.4	3.45	48.2	33.1	3.49	50.6	32.4	3.56
95	31.8	24.6	3.39	33.5	25.4	3.46	34.9	26.2	3.53	36.0	27.0	3.60	36.7	26.7	3.64	38.6	26.5	3.67	40.5	25.9	3.75
115	27.1	25.1	3.73	28.5	25.9	3.80	29.7	26.7	3.88	30.6	27.5	3.96	31.2	27.3	4.00	32.8	27.0	4.04	34.4	26.5	4.12
122	23.9	22.2	3.56	25.1	22.9	3.63	26.2	23.6	3.70	27.0	24.3	3.78	27.5	24.1	3.82	28.9	23.8	3.86	30.4	23.3	3.93

NOTE

- The performance table shows the average value of each conditions.

4. Dimensional Drawing

Wind-Free 4Way Cassette

CNH184DB (AC018BN4DCH/AA), CNH244DB (AC024BN4DCH/AA)

Units : mm [inches]

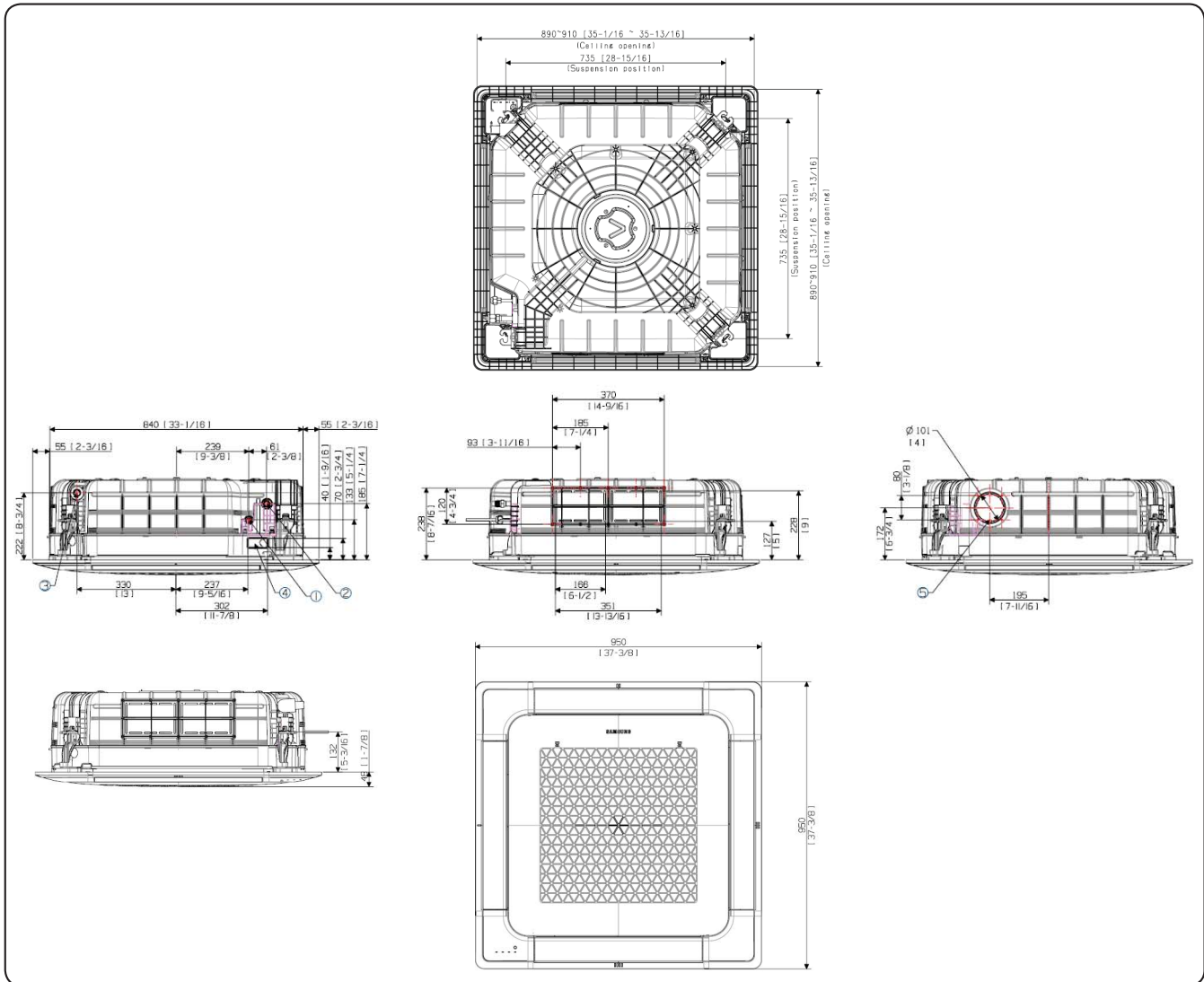

No.	Name	Description	
		CNH184DB (AC018BN4DCH/AA)	CNH244DB (AC024BN4DCH/AA)
1	Liquid pipe connection	Φ 6.35mm(1/4")	
2	Gas pipe connection	Φ 12.7mm(1/2")	Φ 15.88mm(5/8")
3	Drain pipe connection	VP25 [OD32mm(1.26"), ID25mm(0.98")]	
4	Power supply & Communication wiring conduit		
5	Fresh air intake knockout hole	Φ101mm(4") , Use M4 Screw	

NOTE

- As for suspension bolt, please use M8 ~ M10.
(Procured at local site)

4. Dimensional Drawing

Wind-Free 4Way Cassette

CNH304DB (AC030BN4DCH/AA), CNH364DB (AC036BN4DCH/AA)

Units : mm [inches]

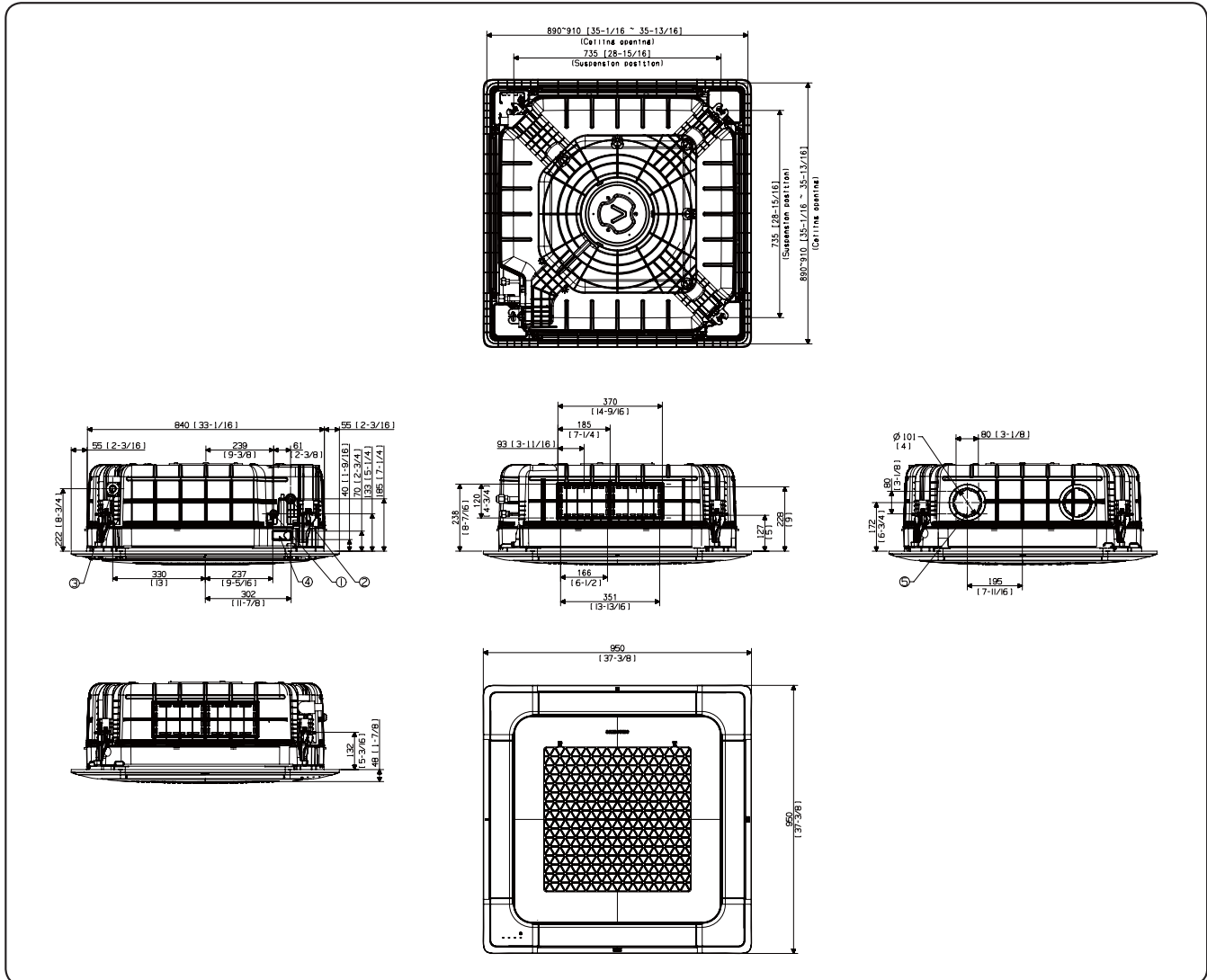

No.	Name	Description
1	Liquid pipe connection	Φ 9.52mm(3/8")
2	Gas pipe connection	Φ 15.88mm(5/8")
3	Drain pipe connection	VP25[OD32mm(1.26", ID25mm(0.98"))]
4	Power supply & Communication wiring conduit	
5	Fresh air intake knockout hole	Φ101mm(4") , Use M4 Screw

NOTE

- As for suspension bolt, please use M8 ~ M10. (Procured at local site)

5. Center of Gravity

Wind-Free 4Way Cassette

Units : mm [inches]

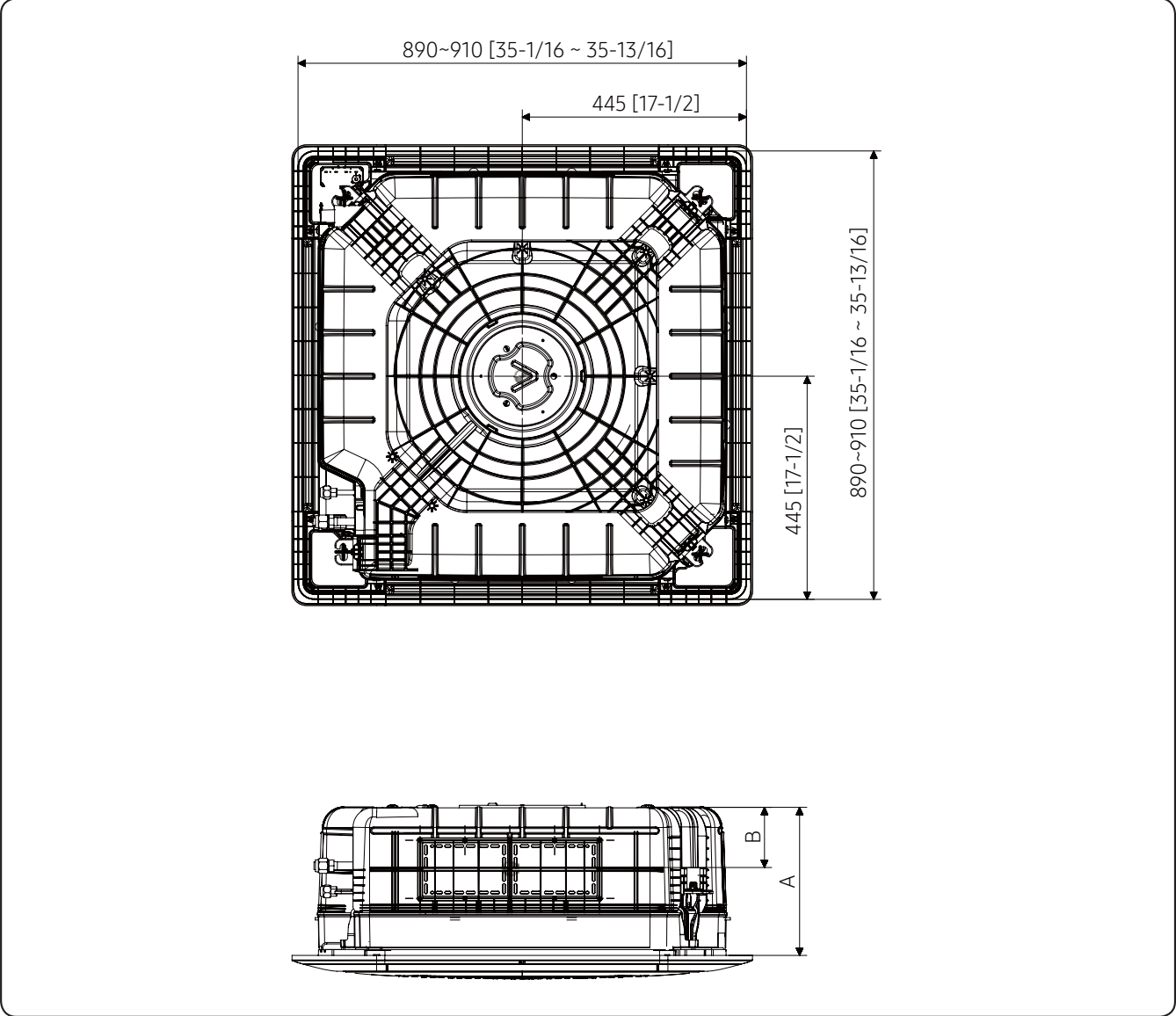

	A	B
~ 24kBtu/h	265 [10-7/16]	114 [4-1/2]
30~ 36kBtu/h	305 [12]	130 [5-1/8]

6. Electrical Wiring Diagram

Wind-Free 4Way Cassette

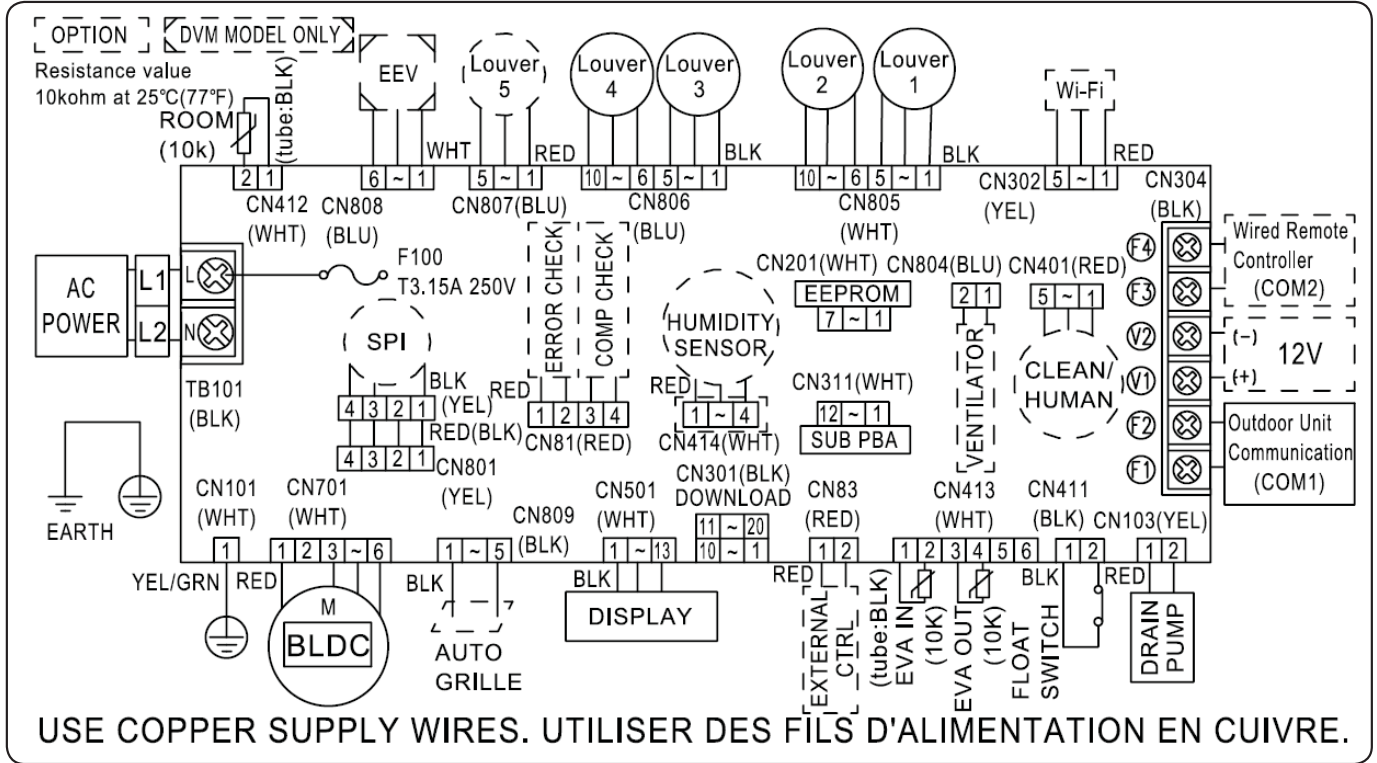

SUB PBA	Printed Circuit Board(SUB)	SPI	S-Plasma ion	ROOM(10K)	Thermistor ROOM OUT(10K)
M-BLDC	BLDC Motor	EEV	Electronic Expansion Valve	EVA-IN(10K)	Thermistor EVA IN(10K)
		EXT_CONTROL	EXTERNAL_CONTROL	EVA-OUT(10K)	Thermistor EVA OUT(10K)

NOTE

- This wiring diagram applies only to the Indoor unit.
- Symbols show as follow :
blk: black, red: red, blu: blue, wht: white, yel: yellow, brn: brown, sky: skyblue: grn: green
- For connection wiring indoor-outdoor transmission F1-F2, indoor-wired remote controller transmission F3-F4.
- Protective earth(screw), : connector, : The wire quantity

7. Sound Data

Wind-Free 4Way Cassette

Sound Pressure level

Unit: dB(A)

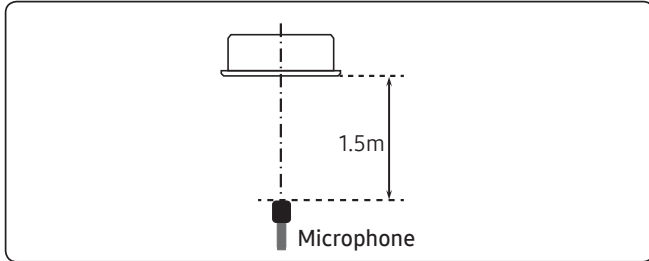

Model	High	Mid	Low
CNH184DB (AC018BN4DCH/AA)	36	33	30
CNH244DB (AC024BN4DCH/AA)	36	33	30
CNH304DB (AC030BN4DCH/AA)	37	34	30
CNH364DB (AC036BN4DCH/AA)	43	38	33

- NC Curve

1) CNH184DB (AC018BN4DCH/AA)

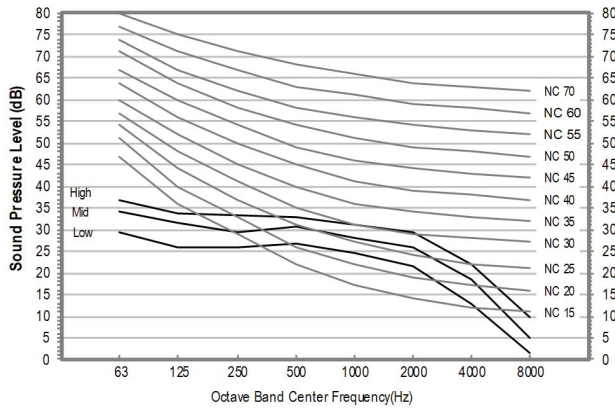

2) CNH244DB (AC024BN4DCH/AA)

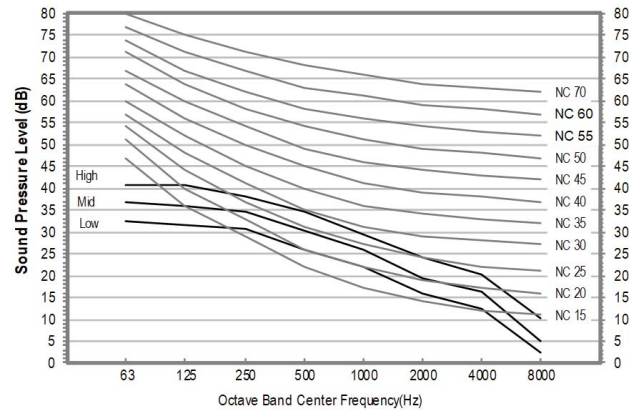

3) CNH304DB (AC030BN4DCH/AA)

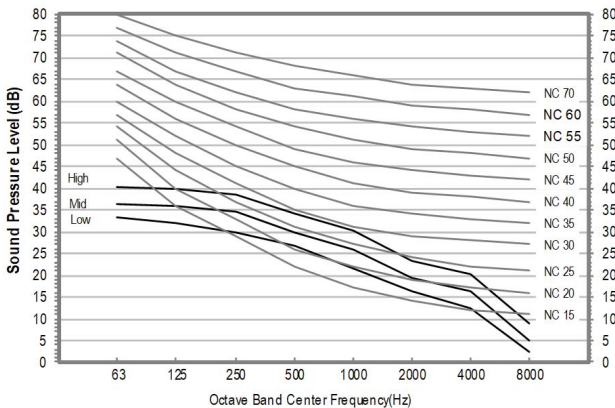

4) CNH364DB (AC036BN4DCH/AA)

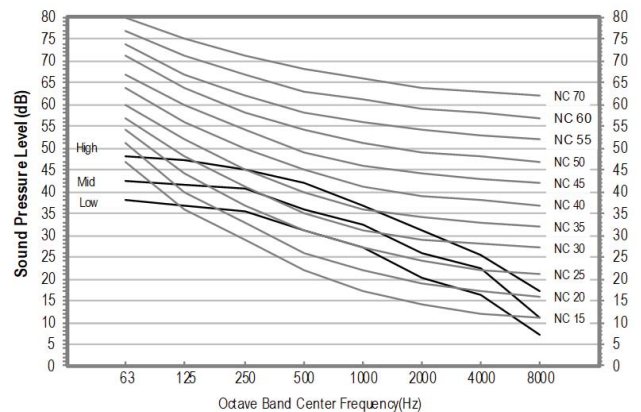

NOTE

- Specifications may be subject to change without prior notice.
 - Sound pressure level is obtained in an anechoic room.
 - Sound pressure level is a relative value, depending on the distance and acoustic environment.
 - Sound pressure level may differ depending on operation condition.
 - dB(A) = A weighted sound pressure level
 - Reference acoustic pressure 0 dB = 20μPa

7. Sound Data

Wind-Free 4Way Cassette

Sound Power level

Unit: dB(A)

NOTE

- Specifications may be subject to change without prior notice
 - Sound power level is an absolute value that a sound source generates.
 - dBA = A-weighted sound power level.
 - Reference power : 1pW.
 - Measured according to ISO 3741.

Model	Cooling
CNH184DB (AC018BN4DCH/AA)	53
CNH244DB (AC024BN4DCH/AA)	53
CNH304DB (AC030BN4DCH/AA)	53
CNH364DB (AC036BN4DCH/AA)	59

• NC Curve

1) CNH184DB (AC018BN4DCH/AA)

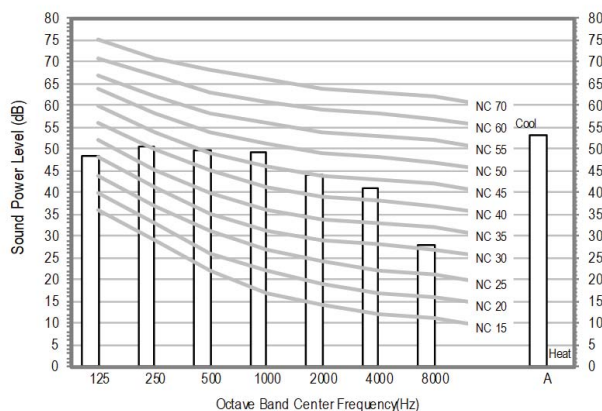

2) CNH244DB (AC024BN4DCH/AA)

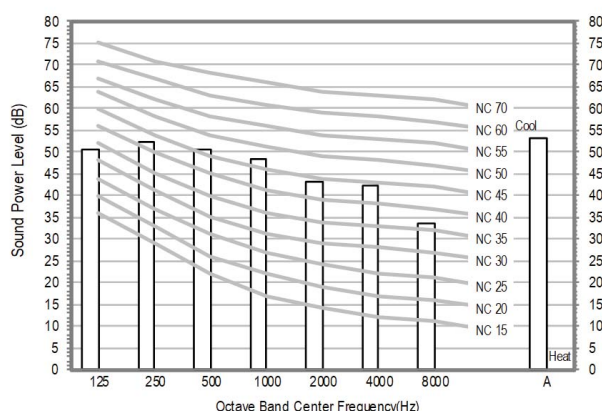

3) CNH304DB (AC030BN4DCH/AA)

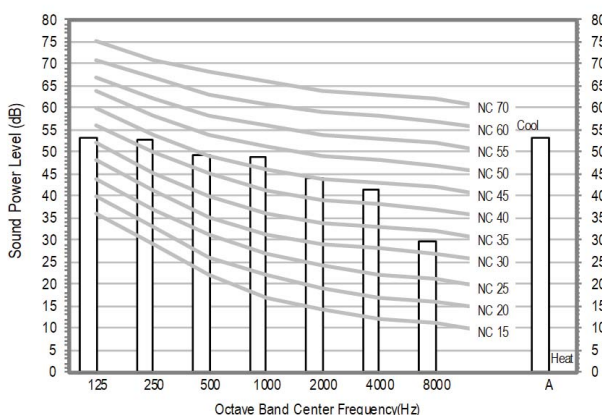

4) CNH364DB (AC036BN4DCH/AA)

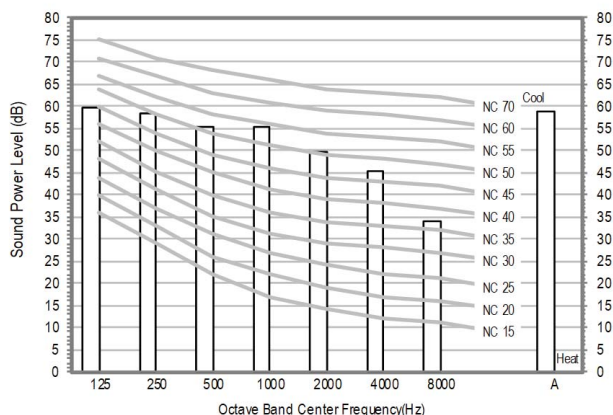

8. Temperature and air flow distribution

Wind-Free 4Way Cassette

CNH184DB (AC018BN4DCH/AA)

- Cooling Air Velocity distribution
(Discharge angle : 45 degree)

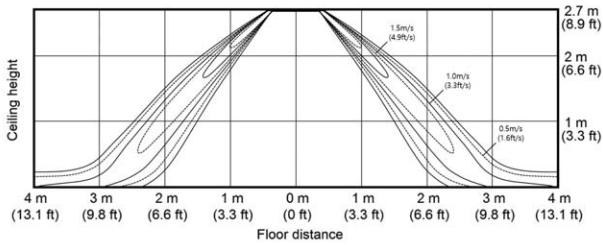

- Cooling temperature distribution
(Discharge angle : 45 degree)

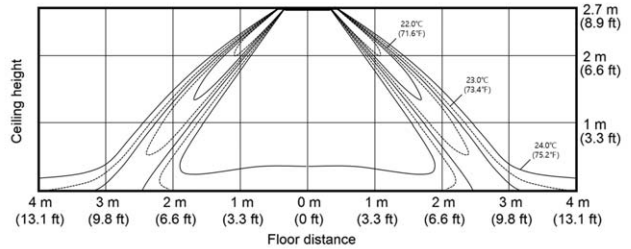

CNH244DB (AC024BN4DCH/AA)

- Cooling Air Velocity distribution
(Discharge angle : 45 degree)

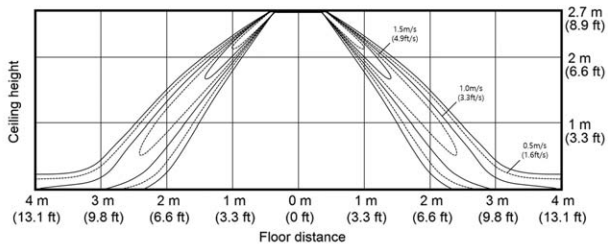

- Cooling temperature distribution
(Discharge angle : 45 degree)

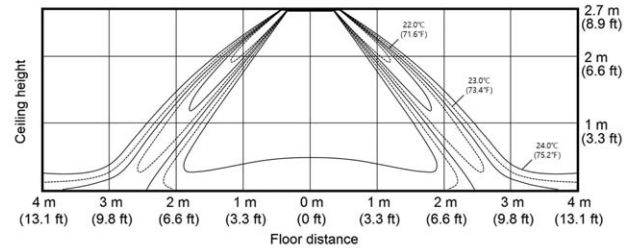

CNH304DB (AC030BN4DCH/AA)

- Cooling Air Velocity distribution
(Discharge angle : 45 degree)

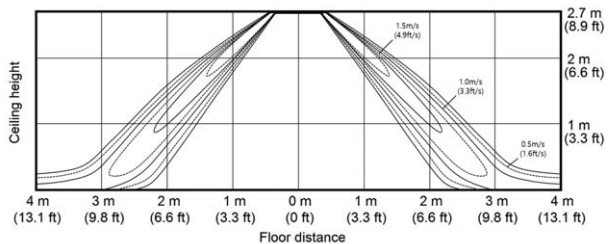

- Cooling temperature distribution
(Discharge angle : 45 degree)

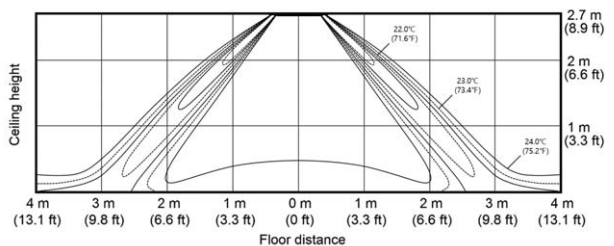

CNH364DB (AC036BN4DCH/AA)

- Cooling Air Velocity distribution
(Discharge angle : 45 degree)

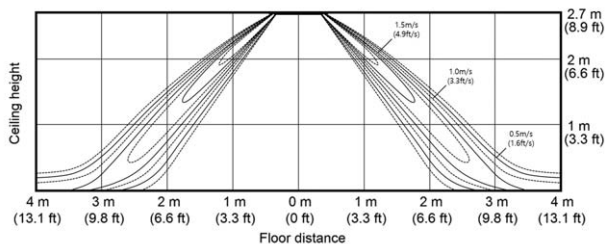

- Cooling temperature distribution
(Discharge angle : 45 degree)

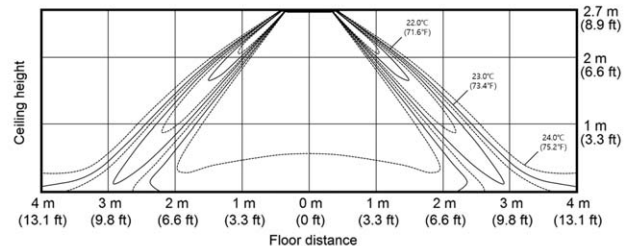

Duct S

1. Specification	28
2. Summary Table	32
3. Capacity Table	33
4. Dimensional Drawing	35
5. Center of Gravity	37
6. Electrical Wiring Diagram	38
7. Sound Data	39
8. Temperature and air flow distribution	41

Features & Benefits

Duct S

Overview

Samsung Ducted Type air conditioning units are a smart solution for low-maintenance, consistent cooling and heating performance in any environment. Their compact, slim frame blends seamlessly into ceilings, enhancing the beauty of the interior space and affording users more flexible installation options. Offering a comprehensive lineup, Samsung Ducted Type air conditioning units offer just the right solution for every need--from the office or shop to the restaurant kitchen.

Experience performance and convenient comfort for any weather condition

Samsung Duct S delivers unparalleled cooling and heating and flexible management with customizable comfort settings in any climate—all year round. Plus, it boasts a slim, compact size and multiple access points for easy setup exactly where needed.



Smart pressure control

Samsung Ducted Type units feature a smart pressure control system. This system adjusts the fan speed based on the external static pressure (ESP), delivering consistent cooling and heating power, regardless of the surrounding environment.

Convenient installation

The optional lift-up drain pump lifts condensed water up to 27.6 inch, compared to a limit of 29.5 inch on conventional models, for flexible and convenient installation.

The Duct S indoor air conditioning unit delivers smooth, consistent operation and convenience with features such as:

- Efficient operation. Stage the desired atmosphere with energy-efficient performance and customized airflow.
 - Smart management. Cool spaces efficiently and manage the air conditioning unit even while away, with features designed for efficiency and control.
 - Easy, flexible setup. Install and maintain even multiple units with a compact and easily accessible design.
-

1. Specification

Duct S

Model Name		Indoor Unit		AC018BNHDCH/AA		AC024BNHDCH/AA			
US Code		Indoor Unit		CNH18HDB		CNH24HDB			
		Outdoor Unit		CXC18SCB		CXC24SCB			
System	Mode			-	Cooling Only		Cooling Only		
	Performance	Capacity (Min/Std/Max)	Cooling	kW	1.17/5.28/6.45		1.76/7.03/8.79		
				Btu/h	4,000 / 18,000 / 22,000		6,000 / 24,000 / 30,000		
				US RT	0.33/1.50/1.83		0.50/2.00/2.50		
			Heating	kW	-		-		
				Btu/h	-		-		
				US RT	-		-		
	Power	Power Input (Min/Std/Max)	Cooling	kW	0.27 / 1.57 / 2.20		0.35 / 2.22 / 3.84		
			Heating		-		-		
		Current Input (Min/Std/Max)	Cooling	A	1.7 / 7.1 / 9.7		2.1 / 10.0 / 16.9		
			Heating		-		-		
		Current	MCA	A	13.5		20.1		
			MFA	A	15		25		
	Efficiency	EER	Cooling	-	3.36		3.17		
			Cooling(US)	(Btu/h)/W	11.50		10.80		
		COP	Heating	W/W	-		-		
		SEER	-	-	20.5		19.0		
		HSPF	-	-	-		-		
	Pipe Connections	Liquid Pipe		Type	Flare		Flare		
				Φ, mm(inch)	6.35 (1/4)		6.35 (1/4)		
		Gas Pipe		Type	Flare		Flare		
				Φ, mm(inch)	12.7 (1/2)		15.88 (5/8)		
		Heat Insulation		-	Both liquid and gas pipes		Both liquid and gas pipes		
		Pipe Length (ODU-IDU)	Standard	Max.	m (ft)	7.5 (24.6)		7.5 (24.6)	
				Elevation	m (ft)	30 (98.4)		50 (164.0)	
	Chargeless			m (ft)	20 (65.6)		30 (98.4)		
				m (ft)	7.5 (24.6)		7.5 (24.6)		
	Wiring Connections	Communication	Min.	mm ²	0.75		0.75		
Remark			-	F1,F2		F1,F2			
Refrigerant	Type		-	R410A		R410A			
	Factory Charging		kg	1.3		2			
Option Code	Standard		-	01B3FC-1C5416-2F343C-370020		01B3FC-1C542A-27484F-370020			
	Install		-	020010-120000-200000-300000		020010-120000-200000-300000			
Indoor Unit	Power Supply			Φ,#,V,Hz	1,2,208-230,60		1,2,208-230,60		
	Heat Exchanger	Type		-	Fin & Tube		Fin & Tube		
		Material	Fin	-	Al		Al		
			Tube	-	Cu		Cu		
	Fin Treatment		-	Hydrophile		Hydrophile			
	Fan	Type		-	Sirocco		Sirocco		
		Quantity		EA	3		3		
		Air Flow Rate	H/M/L	m ³ /min	17.5/15.2/13.5		21.2/19/16.8		
				ft ³ /min	618/537/477		749/671/593		
				l/s	292/253/225		353/317/280		
	External Static Pressure	Min/Std/Max	In Wg	0.10/0.18/0.79		0.10/0.18/0.79			
	Fan Motor	Type		-	BLDC		BLDC		
		Output		W x n	153		153		
	Drain	Drain Pipe		Φ, mm	OD26.67		OD26.67		
	Sound	Sound Pressure Level	H/M/L(Silent)	dB(A)	34/30/26		36/32/28		
		Sound Power Level		dB(A)	56		58		
	External Dimension	Net Weight		kg(lbs)	34.9 (76.9)		35.0 (77.2)		
		Gross Weight		kg(lbs)	39.4 (86.9)		39.5 (87.1)		
		Net Dimensions (WxHxD)		mm	1,200 x 250 x 700		1,200 x 250 x 700		
				inch	47.24 x 9.84 x 25.56		47.24 x 9.84 x 25.56		
Gross Dimensions (WxHxD)		mm	1,429 x 320 x 779		1,429 x 320 x 779				
		inch	56.26 x 15.60 x 30.67		56.26 x 15.60 x 30.67				

1. Specification

Duct S

Model Name		Indoor Unit		AC018BNHDCH/AA	AC024BNHDCH/AA	
US Code		Outdoor Unit		AC018BXSCCC/AA	AC024BXSCCC/AA	
		Indoor Unit		CNH18HDB	CNH24HDB	
		Outdoor Unit		CXC18SCB	CXC24SCB	
Indoor Unit	Casing	Material	-	Steel	Steel	
	Control System	Infrared remote control	-	AR-EH04U	AR-EH04U	
	Drain Pump	Drain Pump	-	Included	Included	
	Additional Accessories	Max.lifting Height / Displacement		in / gal/h	29.53 / 6.34	29.53 / 6.34
		Air Filter		-	-	-
Outdoor Unit	Power Supply		Φ,#,V,Hz	1,2,208-230,60	1,2,208-230,60	
	Heat Exchanger	Type		-	Fin & Tube	Fin & Tube
		Material	Fin	-	Al	Al
			Tube	-	Cu	Cu
	Fin Treatment		-	Green Hydrophile	Green Hydrophile	
	Compressor	Model		-	UG9TK3150FE4SG	UG4T200FUAE4SG
		Type		-	BLDC	BLDC
		Output		kW	1.42	1.79
		Oil	Type	-	POE	POE
	Initial Charge		cc (fl oz)	500	650	
	Fan	Type		-	Propeller	Propeller
		Discharge direction		-	Front	Front
		Quantity		EA	1	1
		Air Flow Rate	H/M/L	m ³ /min	40	51
				ft ³ /min	1,413	1,801
	l/s			667	850	
	Fan Motor	Type		-	BLDC	BLDC
		Output		W x n	125 x 1	125 x 1
	Sound	Sound Pressure Level	Cooling	dB(A)	48	50
			Heating	dB(A)	-	-
		Sound Power Level		dB(A)	62	65
	External Dimension	Net Weight		kg(lbs)	40.5 (89.3)	52.5 (115.7)
		Gross Weight		kg(lbs)	43.5 (95.9)	56.5 (124.6)
Net Dimensions (WxHxD)		mm	880 x 638 x 310	880 x 798 x 310		
		inch	34.65 x 25.12 x 12.20	34.65 x 31.42 x 12.20		
Gross Dimensions (WxHxD)		mm	1,023 x 730 x 413	1,023 x 881 x 413		
		inch	40.28 x 28.74 x 16.26	40.28 x 34.69 x 16.26		
Casing	Material	Body	-	Steel	Steel	
		Operating Temp. Range		°C (°F)	-40~50 (-40~122)	-40~50 (-40~122)
		Heating		°C (°F)	-	

NOTE

- Specification may be subject to change without prior notice.
 - 1) Performances are based on the following test conditions.
 - Cooling : Indoor temperature : 80°F(26.7°C) DB, 67°F(19.4°C) WB, Outdoor temperature : 95°F(35°C) DB, 75°F(23.9°C) WB
 - Heating : Indoor temperature : 70°F(21.1°C) DB, 60°F(15.6°C) WB, Outdoor temperature : 47°F(8.3°C) DB, 43°F(6.1°C) WB
 - Equivalent refrigerant piping length 5m(16.4ft), Level differences : 0m(0ft)
 - 2) Select wire size based on the value of MCA
 - 3) Sound pressure level is obtained in an anechoic room.
 - Sound pressure level is a relative value, depending on the distance and acoustic environment.
 - Sound pressure level may differ depending on operation condition.
 - dBA = A-weighted sound pressure level / Reference acoustic pressure 0 dB = 20uPa
 - 4) Sound power level is an absolute value that a sound source generates.
 - dBA = A-weighted sound power level
 - Reference power : 1pW / Measured according to ISO 3741
 - 5) These products contain R410A which is fluorinated greenhouse gas.

1. Specification

Duct S

Model Name		Indoor Unit		AC030BNHDCH/AA		AC036BNHDCH/AA			
US Code		Indoor Unit		CNH30HDB		CNH36HDB			
		Outdoor Unit		CXC30SCB		CXC36SCB			
System	Mode				Cooling Only		Cooling Only		
	Performance	Capacity (Min/Std/Max)	Cooling	kW	2.52/8.79/10.55		2.93/10.55/11.72		
				Btu/h	8,600 / 30,000 / 36,000		10,000 / 36,000 / 40,000		
				US RT	0.72/2.50/3.00		0.83/3.00/3.33		
			Heating	kW	-		-		
				Btu/h	-		-		
				US RT	-		-		
	Power	Power Input (Min/Std/Max)	Cooling	kW	0.65 / 2.91 / 4.60		0.75 / 3.79 / 4.80		
			Heating		-		-		
		Current Input (Min/Std/Max)	Cooling	A	3.5 / 13.0 / 20.4		3.4 / 16.8 / 21.3		
			Heating		-		-		
		Current	MCA	A	23.5		24.9		
			MFA	A	30		30		
	Efficiency	EER	Cooling		3.02		2.78		
			Cooling(US)	(Btu/h)/W	10.30		9.50		
		COP	Heating	W/W	-		-		
		SEER			17.7		17.0		
		HSPF			-		-		
	Pipe Connections	Liquid Pipe		Type	Flare		Flare		
				Φ, mm(inch)	9.52 (3/8)		9.52 (3/8)		
		Gas Pipe		Type	Flare		Flare		
				Φ, mm(inch)	15.88 (5/8)		15.88 (5/8)		
		Heat Insulation			Both liquid and gas pipes		Both liquid and gas pipes		
		Pipe Length (ODU-IDU)	Standard	Max.	m (ft)	7.5 (24.6)		7.5 (24.6)	
				Elevation	m (ft)	50 (164.0)		50 (164.0)	
	Chargeless			m (ft)	30 (98.4)		30 (98.4)		
				m (ft)	7.5 (24.6)		7.5 (24.6)		
Wiring Connections	Communication	Min.	mm ²	0.75		0.75			
		Remark		F1,F2		F1,F2			
Refrigerant	Type			R410A		R410A			
	Factory Charging		kg	2.4		2.4			
Option Code	Standard			01B3FC-1C59B9-275A5E-370020		01B3FC-1C5933-276975-370045			
	Install			020010-120000-200000-300000		020010-120000-200000-300000			
Indoor Unit	Power Supply		Φ,#,V,Hz	1,2,208-230,60		1,2,208-230,60			
	Heat Exchanger	Type			Fin & Tube		Fin & Tube		
		Material	Fin		Al		Al		
			Tube		Cu		Cu		
	Fin Treatment			Hydrophile		Hydrophile			
	Fan	Type			Sirocco		Sirocco		
		Quantity		EA	3		3		
		Air Flow Rate	H/M/L	m ³ /min	26/21.5/17		33/29/24		
				ft ³ /min	918/759/600		1165/1024/848		
		External Static Pressure	Min/Std/Max	ln Wg	0.10/0.58/0.79		0.12/0.58/0.79		
	Fan Motor	Type			BLDC		BLDC		
		Output		W x n	153		244		
	Drain	Drain Pipe		Φ, mm	OD26.67		OD26.67		
	Sound	Sound Pressure Level	H/M/L(Silent)	dB(A)	41/37/33		43/39/35		
		Sound Power Level		dB(A)	63		65		
	External Dimension	Net Weight		kg(lbs)	35.0 (77.2)		44.0 (97.0)		
		Gross Weight		kg(lbs)	39.5 (87.1)		50.0 (110.2)		
		Net Dimensions (WxHxD)		mm	1,200 x 250 x 700		1,300 x 300 x 700		
				inch	47.24 x 9.84 x 25.56		51.18 x 11.81 x 25.56		
		Gross Dimensions (WxHxD)		mm	1,429 x 320 x 779		1,529 x 370 x 779		
inch	56.26 x 15.60 x 30.67			60.20 x 14.57 x 30.67					

1. Specification

Duct S

Model Name		Indoor Unit		AC030BNHDCH/AA	AC036BNHDCH/AA	
		Outdoor Unit		AC030BXSCCC/AA	AC036BXSCCC/AA	
US Code		Indoor Unit		CNH30HDB	CNH36HDB	
		Outdoor Unit		CXC30SCB	CXC36SCB	
Indoor Unit	Casing	Material	-	Steel	Steel	
	Control	Infrared remote control		AR-EH04U	AR-EH04U	
	System	Wired remote control		MWR-WG00UN/MWR-SH11UN	MWR-WG00UN/MWR-SH11UN	
	Drain Pump	Drain Pump		Included	Included	
		Max.lifting Height / Displacement		in / gal/h	29.53 / 6.34	29.53 / 6.34
Additional Accessories	Air Filter		-	-		
Outdoor Unit	Power Supply		Φ,#,V,Hz	1,2,208-230,60	1,2,208-230,60	
	Heat Exchanger	Type		-	Fin & Tube	
		Material	Fin	-	Al	Al
			Tube	-	Cu	Cu
	Fin Treatment		-	Green Hydrophile	Green Hydrophile	
	Compressor	Model		-	UG8T300FUBJUSG	UG8T300FUBJUSG
		Type		-	BLDC	BLDC
		Output		kW	2.82	2.82
		Oil	Type	-	POE	POE
	Initial Charge		cc (fl oz)	1200	1200	
	Fan	Type		-	Propeller	Propeller
		Discharge direction		-	Front	Front
		Quantity		EA	1	1
		Air Flow Rate	H/M/L	m ³ /min	78	78
				ft ³ /min	2,755	2,755
	l/s			1,300	1,300	
	Fan Motor	Type		-	BLDC	BLDC
		Output		W x n	125 x 1	125 x 1
	Sound	Sound Pressure Level	Cooling	dB(A)	52	54
			Heating	dB(A)	-	-
		Sound Power Level		dB(A)	67	69
	External Dimension	Net Weight		kg(lbs)	71.0 (156.5)	71.0 (156.5)
		Gross Weight		kg(lbs)	76.0 (167.6)	76.0 (167.6)
		Net Dimensions (WxHxD)		mm	940 x 998 x 330	940 x 998 x 330
				inch	37.01 x 39.29 x 12.99	37.01 x 39.29 x 12.99
		Gross Dimensions (WxHxD)		mm	995 x 1,096 x 426	995 x 1,096 x 426
				inch	39.17 x 43.15 x 16.77	39.17 x 43.15 x 16.77
Casing	Material	Body	-	Steel	Steel	
Operating Temp. Range	Cooling		°C (°F)	-40~50 (-40~122)	-40~50 (-40~122)	
	Heating		°C (°F)	-	-	

NOTE

- Specification may be subject to change without prior notice.
 - 1) Performances are based on the following test conditions.
 - Cooling : Indoor temperature : 80°F(26.7°C) DB, 67°F(19.4°C) WB, Outdoor temperature : 95°F(35°C) DB, 75°F(23.9°C) WB
 - Heating : Indoor temperature : 70°F(21.1°C) DB, 60°F(15.6°C) WB, Outdoor temperature : 47°F(8.3°C) DB, 43°F(6.1°C) WB
 - Equivalent refrigerant piping length 5m(16.4ft), Level differences : 0m(0ft)
 - 2) Select wire size based on the value of MCA
 - 3) Sound pressure level is obtained in an anechoic room.
 - Sound pressure level is a relative value, depending on the distance and acoustic environment.
 - Sound pressure level may differ depending on operation condition.
 - dBA = A-weighted sound pressure level / Reference acoustic pressure 0 dB = 20uPa
 - 4) Sound power level is an absolute value that a sound source generates.
 - dBA = A-weighted sound power level
 - Reference power : 1pW / Measured according to ISO 3741
 - 5) These products contain R410A which is fluorinated greenhouse gas.

2. Summary Table

Duct S

Performance Characteristics

Model Code	Net Weight (lbs)	Capacity		Fan Speed	Airflow (Cooling/Heating) (CFM)	Sound Pressure Level (dBA)	Sound Power Level (dBA)	
		Cooling (Btu/h)	Heating (Btu/h)					
CNH18HDB (AC018BNHDCH/AA)	76.9	Max.	22,000	-	High	618 / -	34	56
		Std.	18,000	-	Mid	537 / -	30	-
		Min.	4,000	-	Low	477 / -	26	-
CNH24HDB (AC024BNHDCH/AA)	77.2	Max.	30,000	-	High	749 / -	36	58
		Std.	24,000	-	Mid	671 / -	32	-
		Min.	6,000	-	Low	593 / -	28	-
CNH30HDB (AC030BNHDCH/AA)	77.2	Max.	36,000	-	High	918 / -	41	63
		Std.	30,000	-	Mid	759 / -	37	-
		Min.	8,600	-	Low	600 / -	33	-
CNH36HDB (AC036BNHDCH/AA)	97.0	Max.	40,000	-	High	1,165 / -	43	65
		Std.	36,000	-	Mid	1,024 / -	39	-
		Min.	10,000	-	Low	848 / -	35	-

NOTE

- Sound data is based on cooling operation.

Electric Characteristics

Model		Outdoor Unit				Input Current (Amperes)				Power Supply	
Indoor Unit	Outdoor Unit	Rated	Voltage range		Outdoor Unit		Indoor Unit	Total	MCA(A)	MOP(A)	
		Hz	Volts	Min.	Max	Cooling					Heating
CNH18HDB (AC018BNHDCH/AA)	CXC18SCB(AC018BXSCCC/AA)	60	208 to 230	187	253	11.33	-	2.10	13.43	13.5	15
CNH24HDB (AC024BNHDCH/AA)	CXC24SCB(AC024BXSCCC/AA)	60	208 to 230	187	253	17.95	-	2.10	20.05	20.1	25
CNH30HDB (AC030BNHDCH/AA)	CXC30SCB(AC030BXSCCC/AA)	60	208 to 230	187	253	21.33	-	2.10	23.43	23.5	30
CNH36HDB (AC036BNHDCH/AA)	CXC36SCB(AC036BXSCCC/AA)	60	208 to 230	187	253	21.33	-	3.50	24.83	24.9	30

NOTE

- MCA : Minimum circuit amperes
- MOP: Maximum Overcurrent Protective Device
- Select wire size based on the value of MCA

3. Capacity Table

Duct S

(1) CNH18HDB (AC018BNHDCH/AA) + CXC18SCB (AC018BXSCCC/AA)

Cooling

TC : Total Capacity, SHC : Sensible Heat Capacity, PI : Power Input

Outdoor Temp. (°F, DB)	Indoor Temperature (°F, DB / WB)																				
	68 / 57			72 / 61			77 / 64			80 / 67			82 / 70			86 / 72			90 / 75		
	TC	SHC	PI	TC	SHC	PI	TC	SHC	PI	TC	SHC	PI	TC	SHC	PI	TC	SHC	PI	TC	SHC	PI
	MBH	MBH	kW	MBH	MBH	kW	MBH	MBH	kW	MBH	MBH	kW	MBH	MBH	kW	MBH	MBH	kW	MBH	MBH	kW
-40	23.1	16.7	1.33	24.3	17.2	1.36	25.3	17.7	1.38	26.1	18.3	1.41	26.6	18.1	1.43	28.0	17.9	1.44	29.4	17.5	1.47
0	19.9	14.4	1.48	21.0	14.8	1.51	21.8	15.3	1.54	22.5	15.8	1.57	23.0	15.6	1.59	24.1	15.4	1.60	25.3	15.1	1.63
70	21.5	15.5	1.63	22.6	16.0	1.66	23.6	16.5	1.69	24.3	17.0	1.73	24.8	16.8	1.74	26.0	16.7	1.76	27.3	16.3	1.80
95	15.9	11.5	1.48	16.8	11.9	1.51	17.5	12.2	1.54	18.0	12.6	1.57	18.4	12.5	1.59	19.3	12.3	1.60	20.2	12.1	1.63
115	16.7	13.8	2.22	17.6	14.2	2.26	18.3	14.7	2.31	18.9	15.1	2.36	19.3	15.0	2.38	20.2	14.8	2.40	21.3	14.5	2.45
122	11.9	11.1	1.70	12.6	11.4	1.73	13.1	11.8	1.77	13.5	12.2	1.81	13.8	12.0	1.82	14.5	11.9	1.84	15.2	11.7	1.88

(2) CNH24HDB (AC024BNHDCH/AA) + CXC24SCB (AC024BXSCCC/AA)

Cooling

TC : Total Capacity, SHC : Sensible Heat Capacity, PI : Power Input

Outdoor Temp. (°F, DB)	Indoor Temperature (°F, DB / WB)																				
	68 / 57			72 / 61			77 / 64			80 / 67			82 / 70			86 / 72			90 / 75		
	TC	SHC	PI	TC	SHC	PI	TC	SHC	PI	TC	SHC	PI	TC	SHC	PI	TC	SHC	PI	TC	SHC	PI
	MBH	MBH	kW	MBH	MBH	kW	MBH	MBH	kW	MBH	MBH	kW	MBH	MBH	kW	MBH	MBH	kW	MBH	MBH	kW
-40	25.5	19.7	1.67	26.8	20.3	1.71	27.9	21.0	1.74	28.8	21.6	1.78	29.4	21.4	1.79	30.8	21.2	1.81	32.4	20.7	1.85
0	23.4	18.1	1.46	24.6	18.6	1.49	25.6	19.2	1.52	26.4	19.8	1.55	26.9	19.6	1.57	28.3	19.4	1.59	29.7	19.0	1.62
70	28.7	22.2	1.98	30.2	22.9	2.03	31.4	23.6	2.07	32.4	24.3	2.11	33.0	24.1	2.13	34.7	23.8	2.15	36.4	23.3	2.19
95	21.2	15.3	2.09	22.3	15.8	2.13	23.3	16.3	2.18	24.0	16.8	2.22	24.5	16.6	2.24	25.7	16.5	2.26	27.0	16.1	2.31
115	20.2	16.6	2.72	21.2	17.2	2.77	22.1	17.7	2.83	22.8	18.2	2.89	23.3	18.1	2.91	24.4	17.9	2.94	25.6	17.5	3.00
122	18.0	15.8	2.61	19.0	16.3	2.67	19.8	16.8	2.72	20.4	17.3	2.78	20.8	17.2	2.80	21.8	17.0	2.83	22.9	16.7	2.89

NOTE

- The performance table shows the average value of each conditions.

3. Capacity Table

Duct S

(3) CNH30HDB (AC030BNHDCH/AA) + CXC30SCB (AC030BXSCCC/AA)

Cooling

TC : Total Capacity, SHC : Sensible Heat Capacity, PI : Power Input

Outdoor Temp. (°F, DB)	Indoor Temperature (°F, DB / WB)																				
	68 / 57			72 / 61			77 / 64			80 / 67			82 / 70			86 / 72			90 / 75		
	TC	SHC	PI	TC	SHC	PI	TC	SHC	PI	TC	SHC	PI	TC	SHC	PI	TC	SHC	PI	TC	SHC	PI
	MBH	MBH	kW	MBH	MBH	kW	MBH	MBH	kW	MBH	MBH	kW	MBH	MBH	kW	MBH	MBH	kW	MBH	MBH	kW
-40	30.5	23.6	3.01	32.1	24.3	3.07	33.5	25.1	3.14	34.5	25.9	3.20	35.2	25.6	3.23	36.9	25.4	3.27	38.8	24.9	3.33
0	31.8	24.6	3.01	33.5	25.4	3.07	34.9	26.2	3.14	36.0	27.0	3.20	36.7	26.7	3.23	38.6	26.5	3.27	40.5	25.9	3.33
70	33.2	25.7	2.60	34.9	26.5	2.66	36.4	27.3	2.71	37.5	28.1	2.76	38.3	27.8	2.79	40.2	27.6	2.82	42.2	27.0	2.88
95	26.5	20.5	2.74	27.9	21.2	2.79	29.1	21.8	2.85	30.0	22.5	2.91	30.6	22.3	2.94	32.1	22.1	2.97	33.7	21.6	3.03
115	22.6	20.9	3.01	23.7	21.6	3.07	24.7	22.3	3.14	25.5	23.0	3.20	26.0	22.7	3.23	27.3	22.5	3.27	28.7	22.0	3.33
122	19.9	18.5	2.88	21.0	19.1	2.93	21.8	19.6	2.99	22.5	20.3	3.06	23.0	20.0	3.09	24.1	19.8	3.12	25.3	19.5	3.18

(4) CNH36HDB (AC036BNHDCH/AA) + CXC36SCB (AC036BXSCCC/AA)

Cooling

TC : Total Capacity, SHC : Sensible Heat Capacity, PI : Power Input

Outdoor Temp. (°F, DB)	Indoor Temperature (°F, DB / WB)																				
	68 / 57			72 / 61			77 / 64			80 / 67			82 / 70			86 / 72			90 / 75		
	TC	SHC	PI	TC	SHC	PI	TC	SHC	PI	TC	SHC	PI	TC	SHC	PI	TC	SHC	PI	TC	SHC	PI
	MBH	MBH	kW	MBH	MBH	kW	MBH	MBH	kW	MBH	MBH	kW	MBH	MBH	kW	MBH	MBH	kW	MBH	MBH	kW
-40	36.6	28.3	3.92	38.6	29.2	4.00	40.2	30.1	4.09	41.4	31.1	4.17	42.2	30.7	4.21	44.3	30.4	4.25	46.6	29.8	4.34
0	38.2	29.6	3.92	40.2	30.5	4.00	41.9	31.4	4.09	43.2	32.4	4.17	44.1	32.1	4.21	46.3	31.8	4.25	48.6	31.1	4.34
70	39.8	30.8	3.39	41.9	31.8	3.46	43.7	32.7	3.53	45.0	33.8	3.60	45.9	33.4	3.64	48.2	33.1	3.67	50.6	32.4	3.75
95	31.8	24.6	3.57	33.5	25.4	3.64	34.9	26.2	3.71	36.0	27.0	3.79	36.7	26.7	3.83	38.6	26.5	3.87	40.5	25.9	3.94
115	27.1	25.1	3.92	28.5	25.9	4.00	29.7	26.7	4.09	30.6	27.5	4.17	31.2	27.3	4.21	32.8	27.0	4.25	34.4	26.5	4.34
122	23.9	22.2	3.75	25.1	22.9	3.82	26.2	23.6	3.90	27.0	24.3	3.98	27.5	24.1	4.02	28.9	23.8	4.06	30.4	23.3	4.14

NOTE

- The performance table shows the average value of each conditions.

4. Dimensional Drawing

Duct S

CNH18HDB (AC018BNHDCH/AA), CNH24HDB (AC024BNHDCH/AA), CNH30HDB (AC030BNHDCH/AA)

Units : mm (inches)

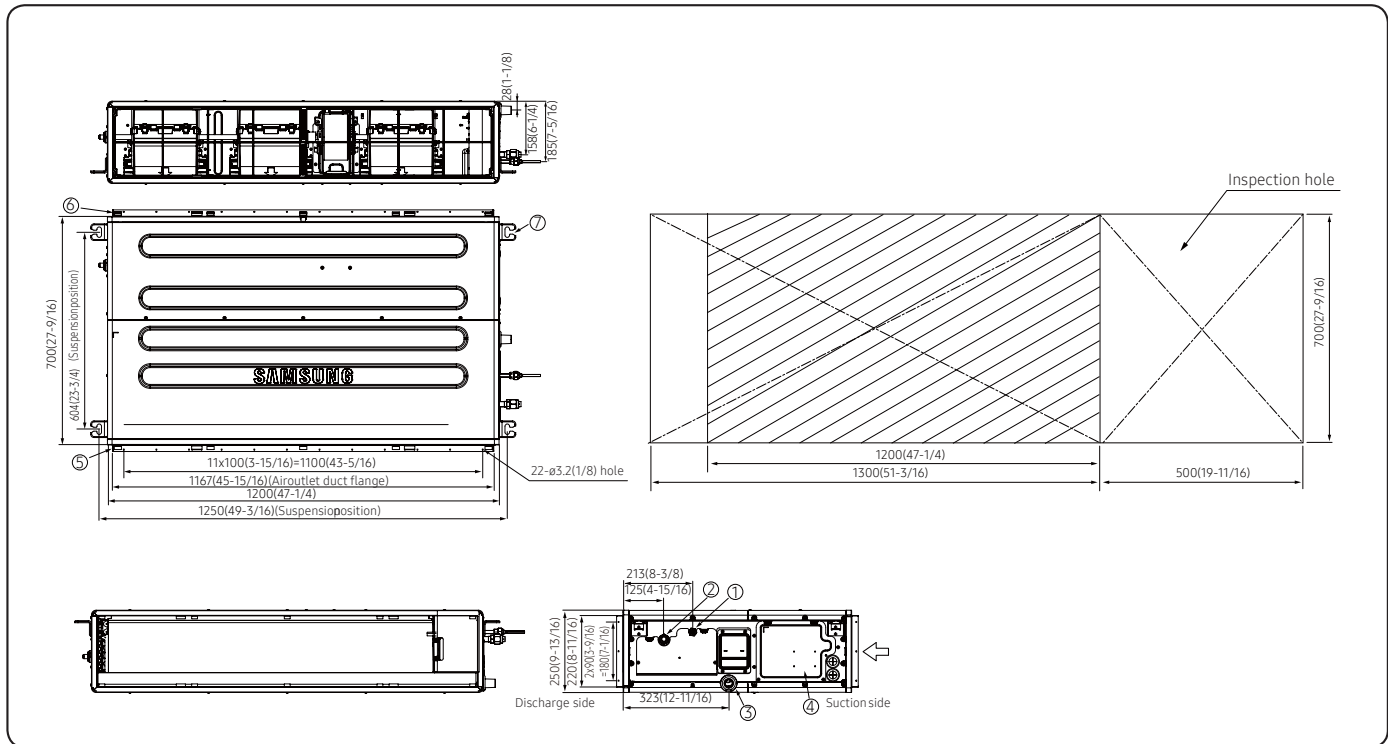

NO	Name	Description		
		CNH18HDB (AC018BNHDCH/AA)	CNH24HDB (AC024BNHDCH/AA)	CNH30HDB (AC030BNHDCH/AA)
1	Liquid pipe connection	Φ6.35 mm(1/4")		Φ9.52 mm(3/8")
2	Gas pipe connection	Φ12.7 mm(1/2")	Φ15.88 mm(5/8")	
3	Drain pipe connection	3/4"[OD26.67mm(1.05")]		
4	Power supply connection	-		
5	Air discharge flange	-		
6	Air filter	-		
7	Hook	M8-M10		

4. Dimensional Drawing

Duct S

CNH36HDB (AC036BNHDCH/AA)

Units : mm (inches)

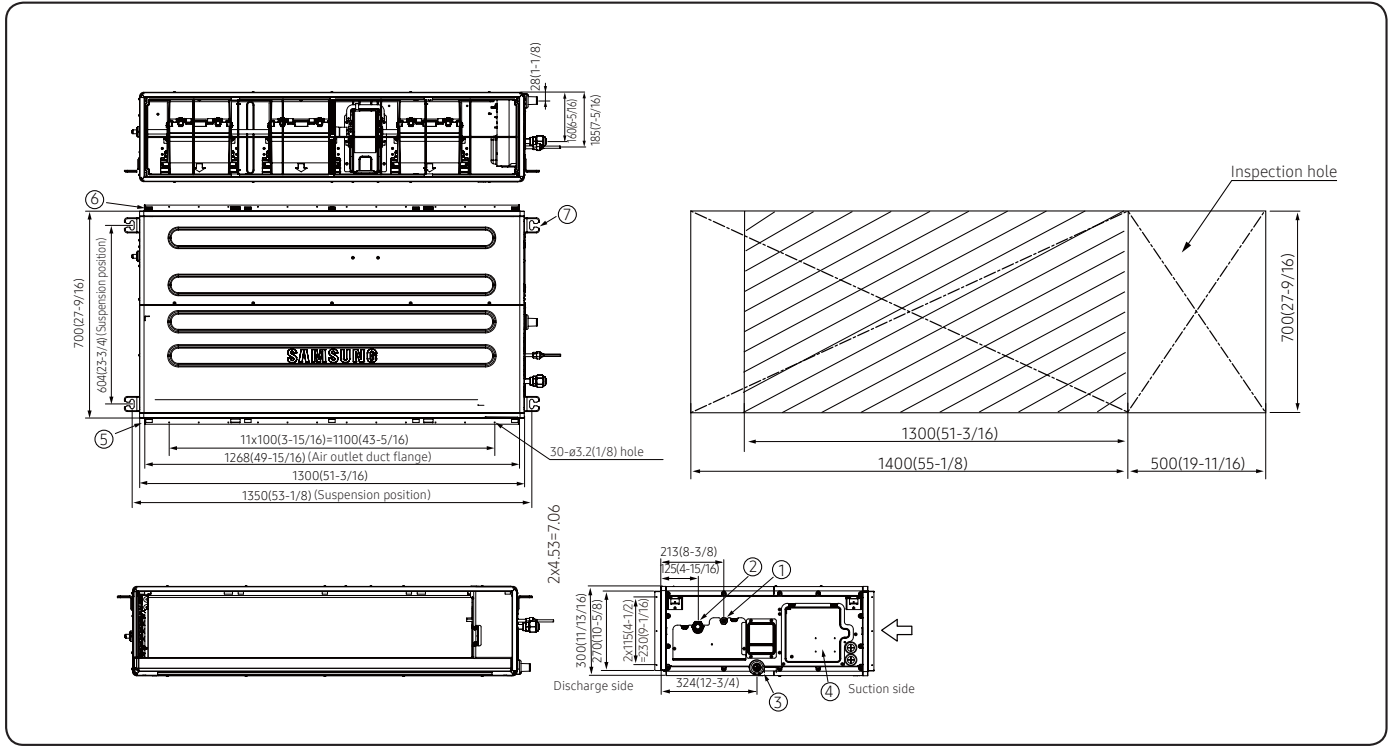

NO	Name	Description
1	Liquid pipe connection	Φ9.52 mm(3/8")
2	Gas pipe connection	Φ15.88 mm(5/8")
3	Drain pipe connection	3/4"[OD26.67mm(1.05")]
4	Power supply connection	-
5	Air discharge flange	-
6	Air filter	-
7	Hook	M8~M10

5. Center of Gravity

Duct S

Units : mm [inches]

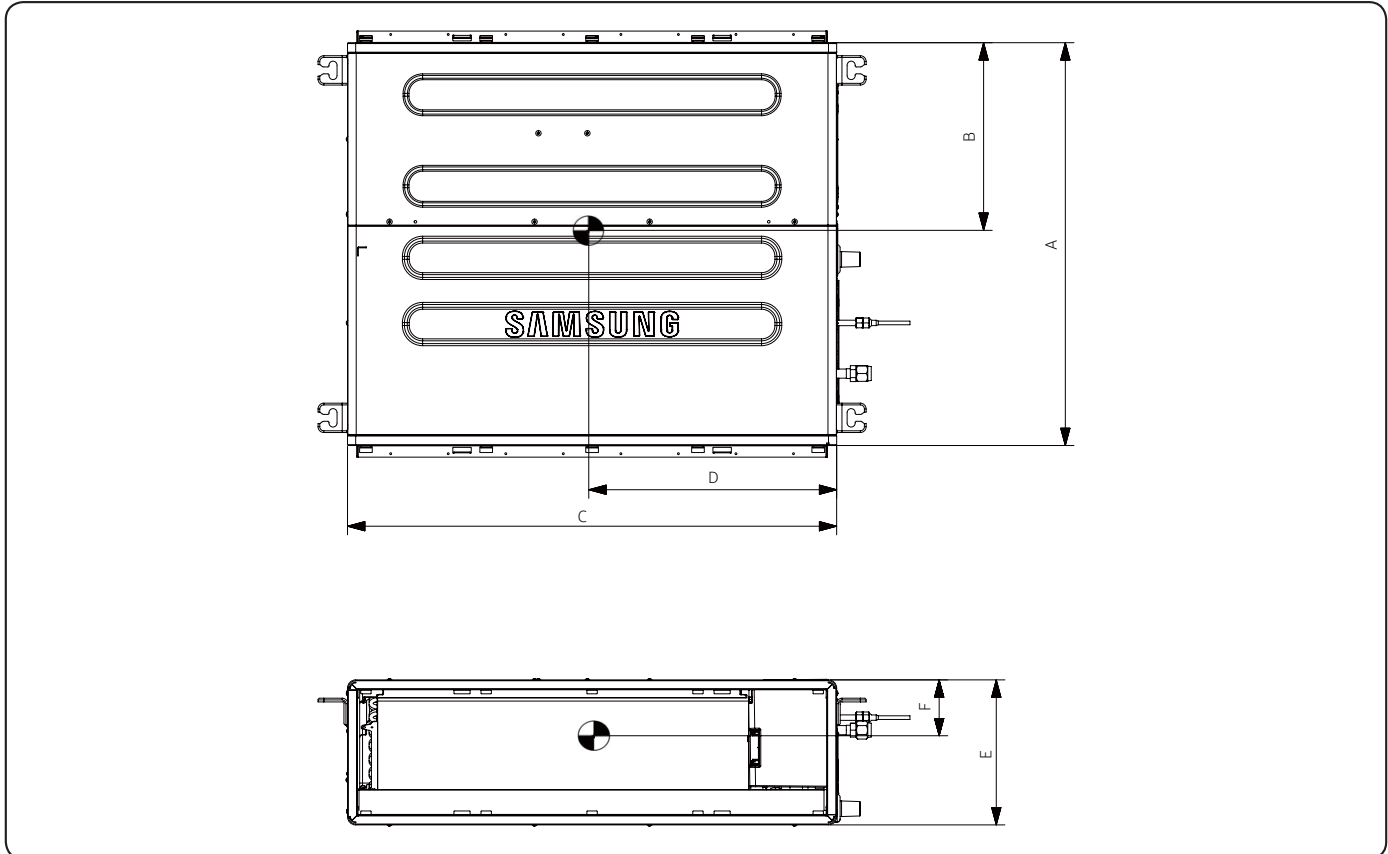

Model	A	B	C	D	E	F
CNH18HDB (AC018BNHDCH/AA) CNH24HDB (AC024BNHDCH/AA) CNH30HDB (AC030BNHDCH/AA)	700 [27-9/16]	265 [10-7/16]	1250 [49-3/16]	565 [18-5/16]	252 [9-15/16]	125 [4-15/16]
CNH36HDB (AC036BNHDCH/AA)	700 [27-9/16]	265 [10-7/16]	1350 [53-1/8]	650 [25-5/8]	301 [11-13/16]	150 [5-15/16]

6. Electrical Wiring Diagram

Duct S

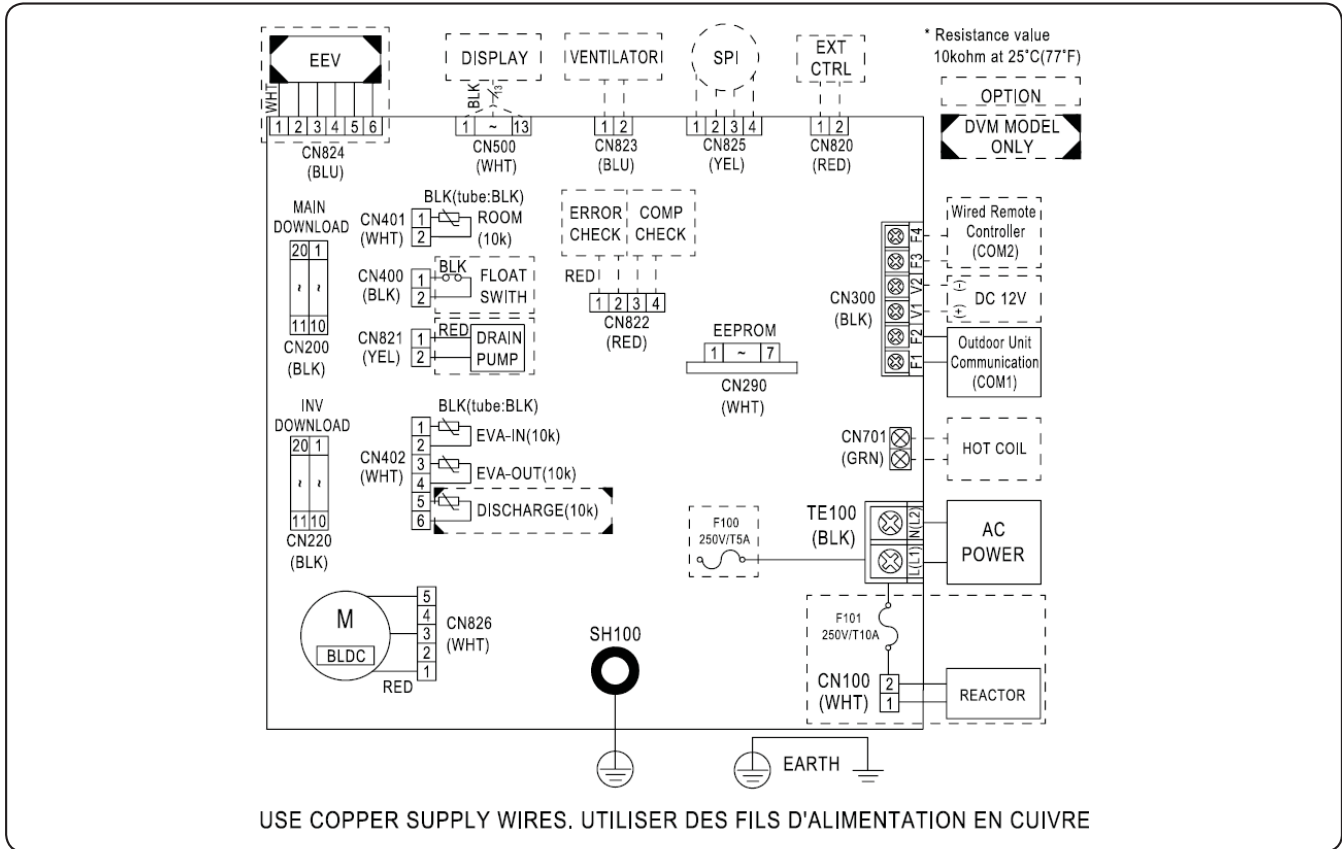

MAIN PBA	Printed circuit board(MAIN)	EEV	Electronic Expansion Valve	ROOM (10K)	Thermistor ROOM in (10K)
EXT_CONTROL	EXTERNAL CONTROL	EVA-IN (10K)	Thermistor EVA IN(10K)	EVA-OUT (10K)	Thermistor EVA OUT(10K)
M-BLDC	BLDC Motor	DISCHARGE(10K)	Thermistor DISCHARGE		

NOTE

- This wiring diagram applies only to the Indoor unit.
- Symbols show as follow :
blk: black, red: red, blu: blue, wht: white, yel: yellow, brn: brown, sky: skyblue: grn: green
- For connection wiring indoor-outdoor transmission F1-F2, indoor-wired remote controller transmission F3-F4.
- Protective earth(screw)

7. Sound Data

Duct S

Sound Pressure level

Unit: dB(A)

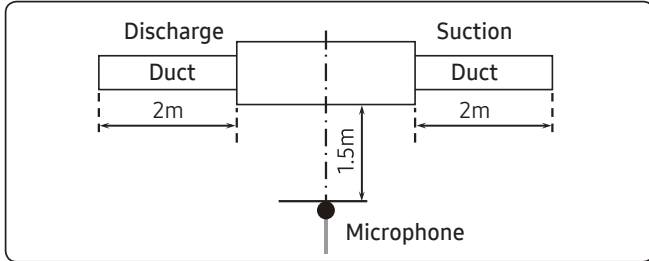

Model	High	Mid	Low
CNH18HDB (AC018BNHDCH/AA)	34	30	26
CNH24HDB (AC024BNHDCH/AA)	36	32	28
CNH30HDB (AC030BNHDCH/AA)	41	37	33
CNH36HDB (AC036BNHDCH/AA)	43	39	35

- NC Curve

1) CNH18HDB (AC018BNHDCH/AA)

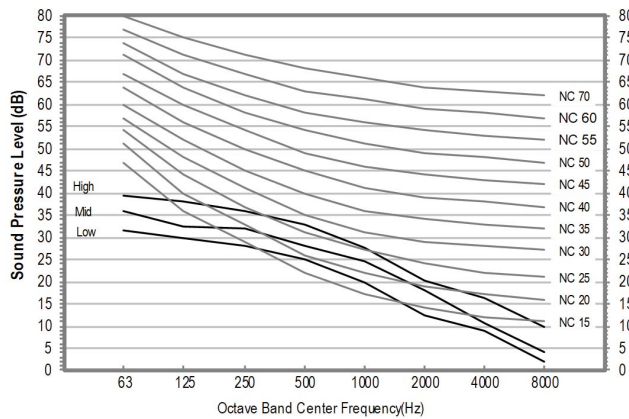

2) CNH24HDB (AC024BNHDCH/AA)

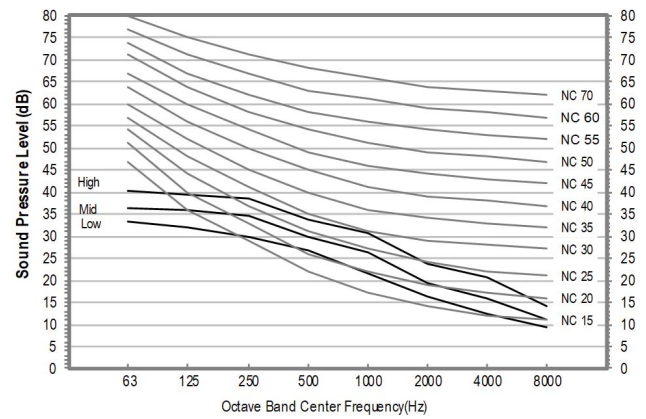

3) CNH30HDB (AC030BNHDCH/AA)

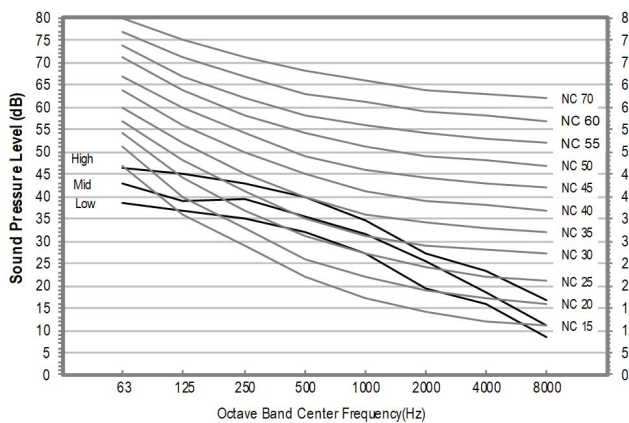

4) CNH36HDB (AC036BNHDCH/AA)

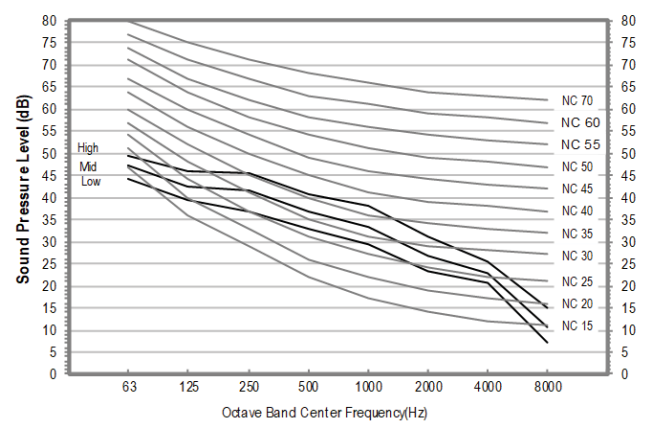

NOTE

- Specifications may be subject to change without prior notice.
 - Sound pressure level is obtained in an anechoic room.
 - Sound pressure level is a relative value, depending on the distance and acoustic environment.
 - Sound pressure level may differ depending on operation condition.
 - dBA = A weighted sound pressure level
 - Reference acoustic pressure 0 dB = 20μPa

7. Sound Data

Duct S

Sound Power level

Unit: dB(A)



- Specifications may be subject to change without prior notice
 - Sound power level is an absolute value that a sound source generates.
 - dBA = A-weighted sound power level.
 - Reference power : 1pW.
 - Measured according to ISO 3741.

Model	Cooling
CNH18HDB (AC018BNHDCH/AA)	56
CNH24HDB (AC024BNHDCH/AA)	58
CNH30HDB (AC030BNHDCH/AA)	63
CNH36HDB (AC036BNHDCH/AA)	65

• NC Curve

1) CNH18HDB (AC018BNHDCH/AA)

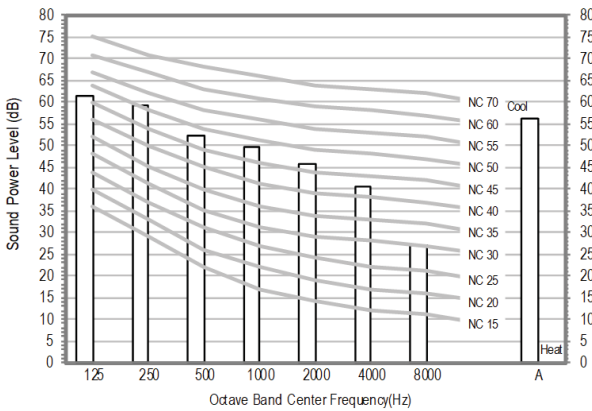

2) CNH24HDB (AC024BNHDCH/AA)

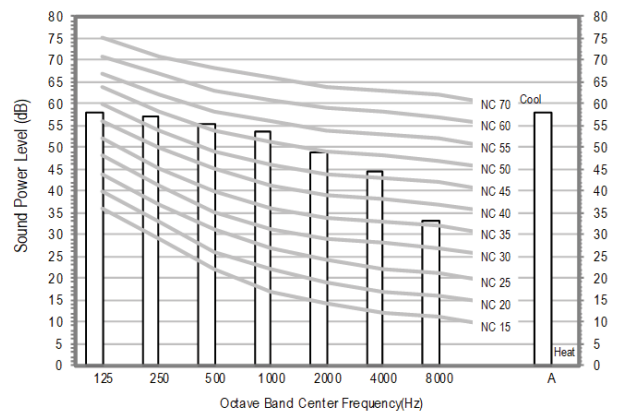

3) CNH30HDB (AC030BNHDCH/AA)

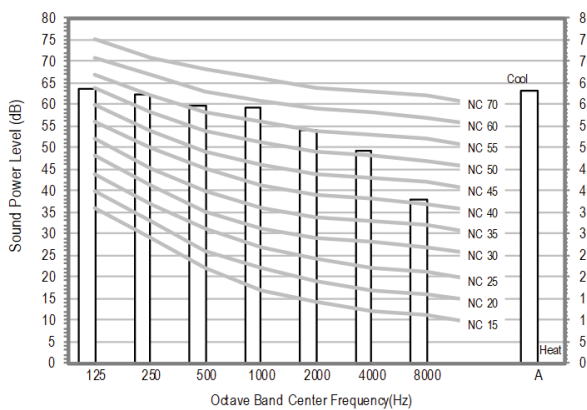

4) CNH36HDB (AC036BNHDCH/AA)

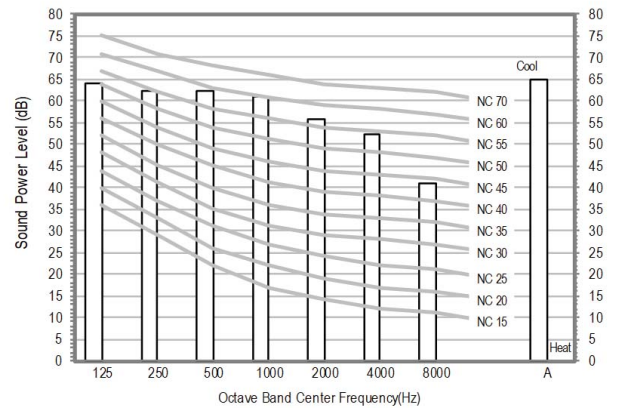

8. Temperature and air flow distribution

Duct S

CNH18HDB (AC018BNHDCH/AA)

①	External Static Pressure(inWg)	Option Code
	$0.1 \leq P \leq 0.2$	01B3FC-1C5416-2F343C-370020

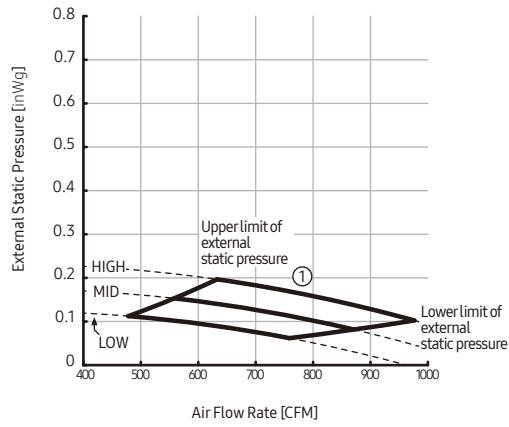

②	External Static Pressure(inWg)	Option Code
	$0.2 < P \leq 0.3$	01B3FC-1C547A-2F343C-370020

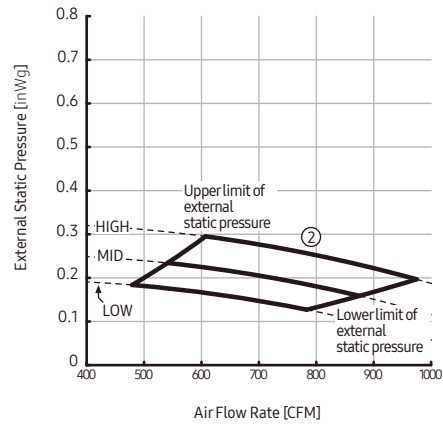

③	External Static Pressure(inWg)	Option Code
	$0.3 < P \leq 0.4$	01B3FC-1C54DF-2F343C-370020

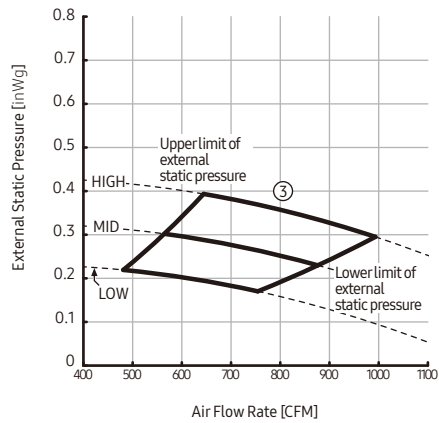

④	External Static Pressure(inWg)	Option Code
	$0.4 < P \leq 0.5$	01B3FC-1C5933-2F343C-370020

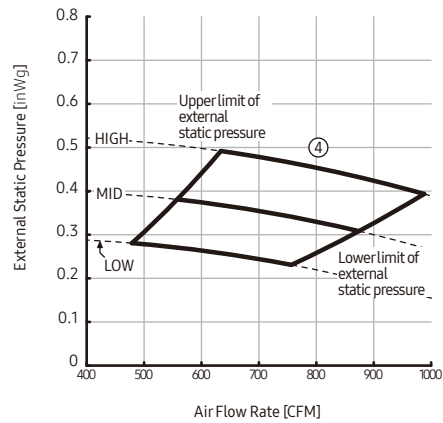

⑤	External Static Pressure(inWg)	Option Code
	$0.5 < P \leq 0.6$	01B3FC-1C5997-2F343C-370020

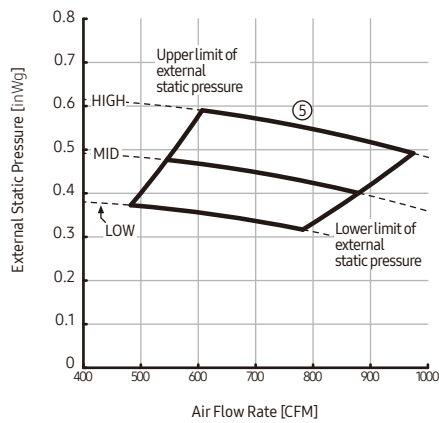

⑥	External Static Pressure(inWg)	Option Code
	$0.6 < P \leq 0.7$	01B3FC-1C59FB-2F343C-370020

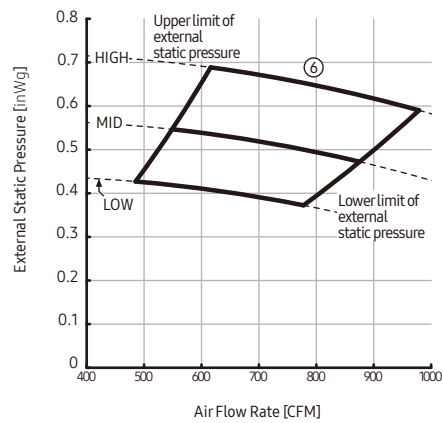

8. Temperature and air flow distribution

Duct S

CNH18HDB (AC018BNHDCH/AA)

⑦	External Static Pressure(inWg)	Option Code
	0.7 < P ≤ 0.8	01B3FC-1C5E50-2F343C-370020

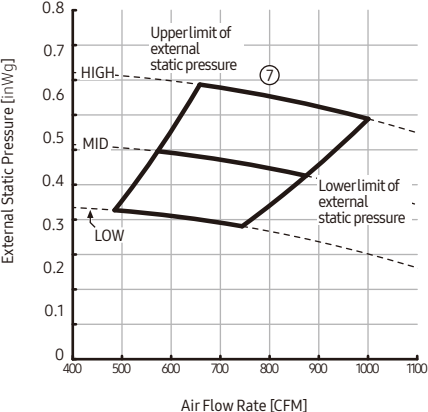

8. Temperature and air flow distribution

Duct S

CNH24HDB (AC024BNHDCH/AA)

①	External Static Pressure(inWg)	Option Code
	$0.1 \leq P \leq 0.2$	01B3FC-1C542A-27484F-370020

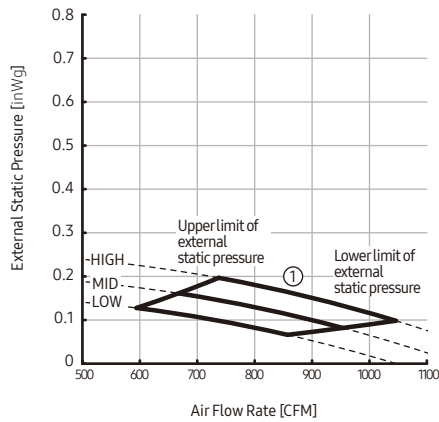

②	External Static Pressure(inWg)	Option Code
	$0.2 < P \leq 0.3$	01B3FC-1C548E-27484F-370020

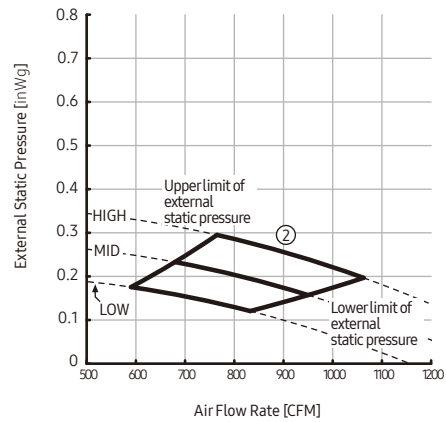

③	External Static Pressure(inWg)	Option Code
	$0.3 < P \leq 0.4$	01B3FC-1C55E1-27484F-370020

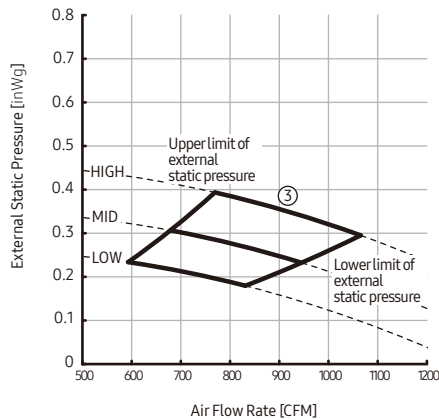

④	External Static Pressure(inWg)	Option Code
	$0.4 < P \leq 0.5$	01B3FC-1C5935-27484F-370020

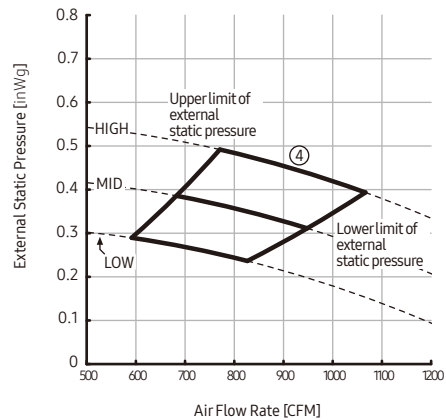

⑤	External Static Pressure(inWg)	Option Code
	$0.5 < P \leq 0.6$	01B3FC-1C5998-27484F-370020

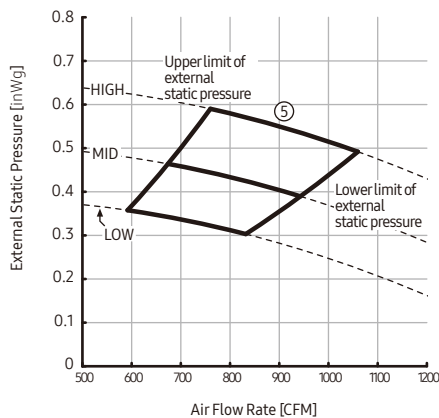

⑥	External Static Pressure(inWg)	Option Code
	$0.6 < P \leq 0.7$	01B3FC-1C59FC-27484F-370020

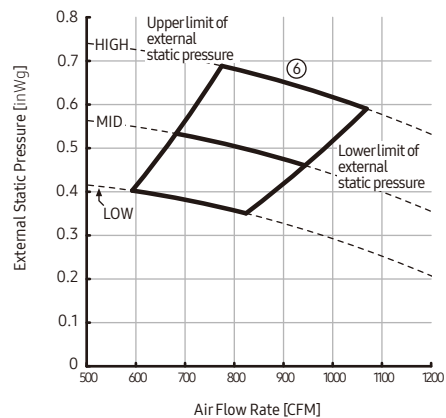

8. Temperature and air flow distribution

Duct S

CNH24HDB (AC024BNHDCH/AA)

⑦	External Static Pressure(inWg)	Option Code
	0.7 < P ≤ 0.8	01B3FC-1C5D5F-27484F-370020

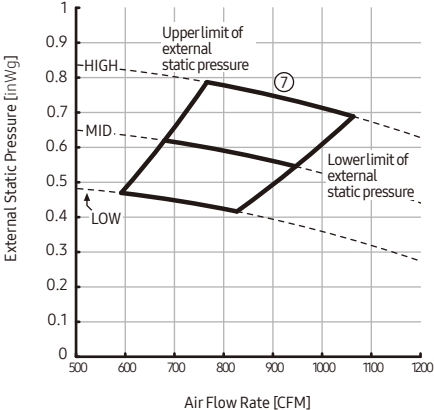

8. Temperature and air flow distribution

Duct S

CNH30HDB (AC030BNHDCH/AA)

①	External Static Pressure(inWg)	Option Code
	$0.1 \leq P \leq 0.2$	01B3FC-1C547B-275A5E-370020

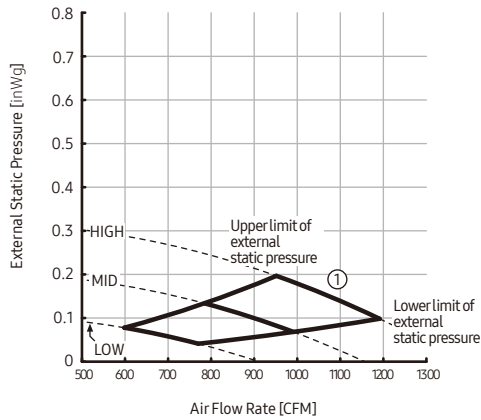

②	External Static Pressure(inWg)	Option Code
	$0.2 < P \leq 0.3$	01B3FC-1C54DE-275A5E-370020

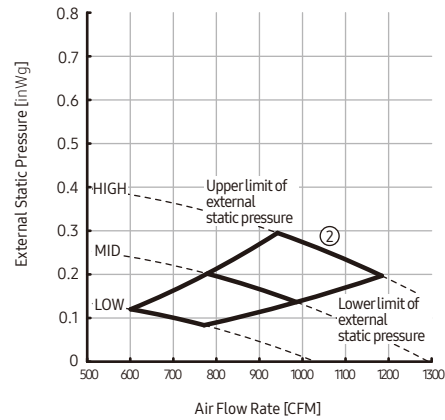

③	External Static Pressure(inWg)	Option Code
	$0.3 < P \leq 0.4$	01B3FC-1C5922-275A5E-370020

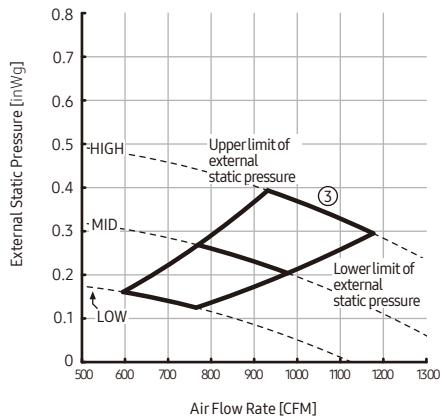

④	External Static Pressure(inWg)	Option Code
	$0.4 < P \leq 0.5$	01B3FC-1C5967-275A5E-370020

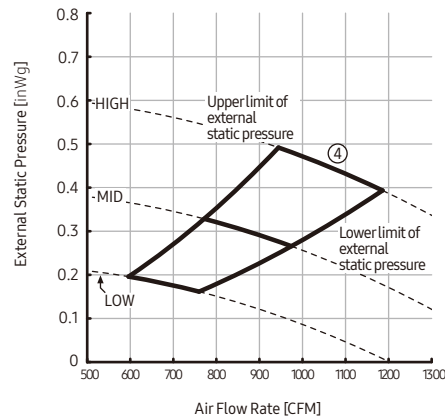

⑤	External Static Pressure(inWg)	Option Code
	$0.5 < P \leq 0.6$	01B3FC-1C59B9-275A5E-370020

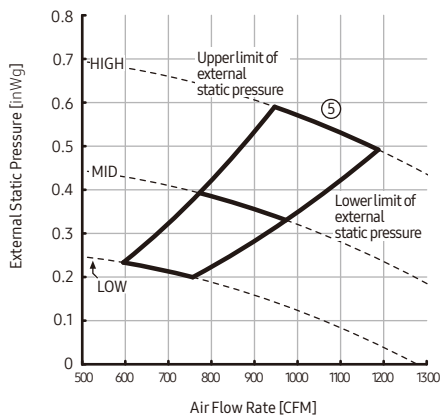

⑥	External Static Pressure(inWg)	Option Code
	$0.6 < P \leq 0.7$	01B3FC-1C59FC-275A5E-370020

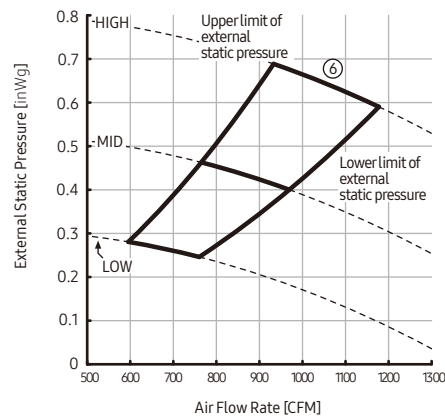

8. Temperature and air flow distribution

Duct S

CNH30HDB (AC030BNHDCH/AA)

⑦	External Static Pressure(inWg)	Option Code
	0.7 < P ≤ 0.8	01B3FC-1C5D3E-275A5E-370020

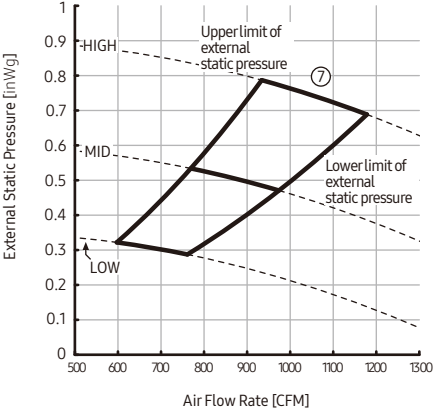

8. Temperature and air flow distribution

Duct S

CNH36HDB (AC036BNHDCH/AA)

①	External Static Pressure(inWg)	Option Code
	2.5 ≤ P ≤ 5	01B3FC-1C5439-276975-370045

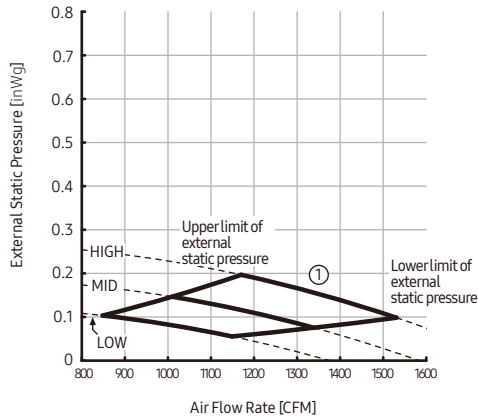

②	External Static Pressure(inWg)	Option Code
	5 < P ≤ 7.5	01B3FC-1C548C-276975-370045

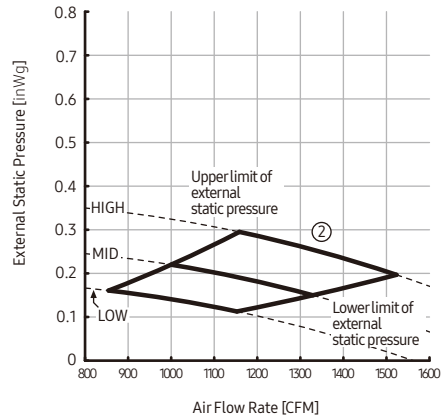

③	External Static Pressure(inWg)	Option Code
	7.5 < P ≤ 10	01B3FC-1C54CE-276975-370045

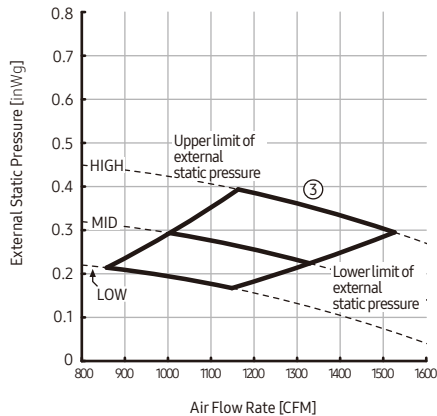

④	External Static Pressure(inWg)	Option Code
	10 < P ≤ 12.5	01B3FC-1C55F1-276975-370045

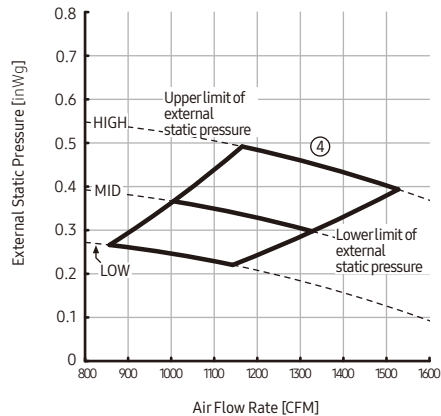

⑤	External Static Pressure(inWg)	Option Code
	12.5 < P ≤ 15	01B3FC-1C5933-276975-370045

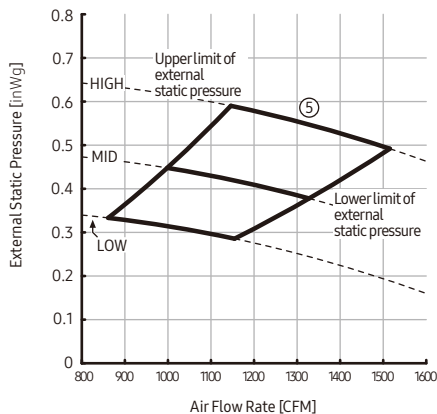

⑥	External Static Pressure(inWg)	Option Code
	15 < P ≤ 17.5	01B3FC-1C5965-276975-370045

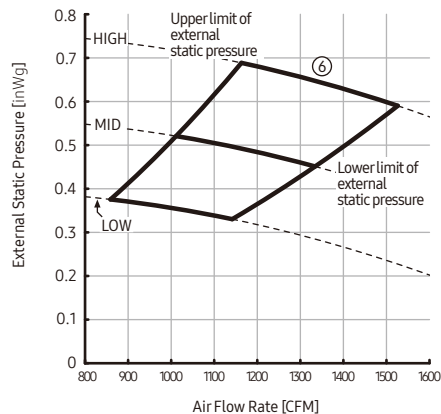

8. Temperature and air flow distribution

Duct S

CNH36HDB (AC036BNHDCH/AA)

⑦	External Static Pressure(inWg)	Option Code
	17.5 < P ≤ 20	01B3FC-1C59A6-276975-370045

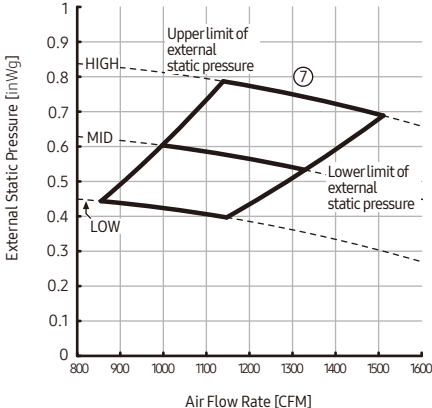

Wall Mounted Type

1. Specification	52
2. Summary Table	56
3. Capacity Table	57
4. Dimensional Drawing	59
5. Center of Gravity	61
6. Electrical Wiring Diagram	62
7. Sound Data	64
8. Temperature and air flow distribution	66

Features & Benefits

Wall Mounted Type (Wind-Free™)

Auto clean

Keep the inside of air conditioner clean and hygienic automatically

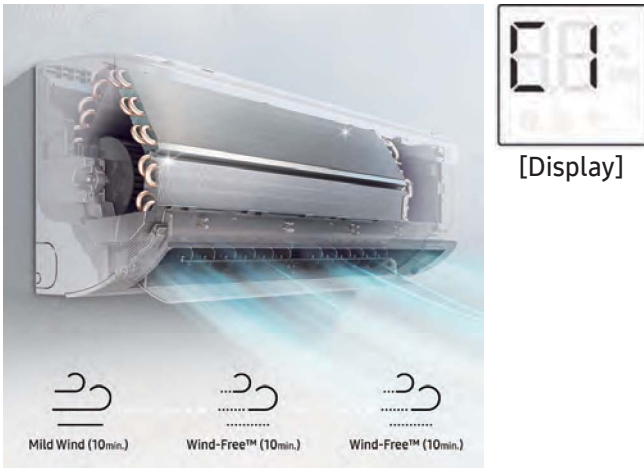

※ The Auto clean time may vary depending on the status of the product.

Quiet Operation

Wind-Free air conditioner work much more smoothly and quietly. At its lowest level, it only generates 21dB(A) of sound (*) which is almost as quiet as a whisper



(*) Tested on the AC026TNXDKG/EU model in quiet mode.

ETO (Emergency Temperature Output)

Protect your computer room safely : Activate a backup system when a unit has stopped due to an error or if room temperature is above the specified threshold

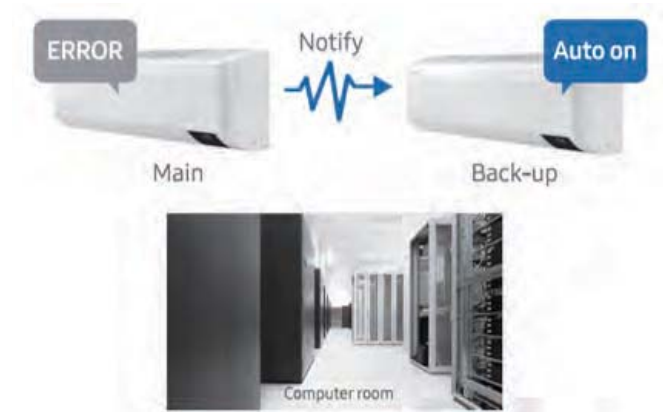

※ Requires additional components (MIM-B14) for each unit

7-Segment display

A large numeric display with clear and simple icons makes it much easier to see the room temperature and intuitively check the current status of your air conditioner - even from a distance.



Features & Benefits

Wall Mounted Type

TURBO Cooling mode

Samsung's air conditioner operates in its maximum speed in Turbo Cooling mode to quickly reach the set temperature. Instantly cool down your space with Samsung's Turbo Cooling technology.

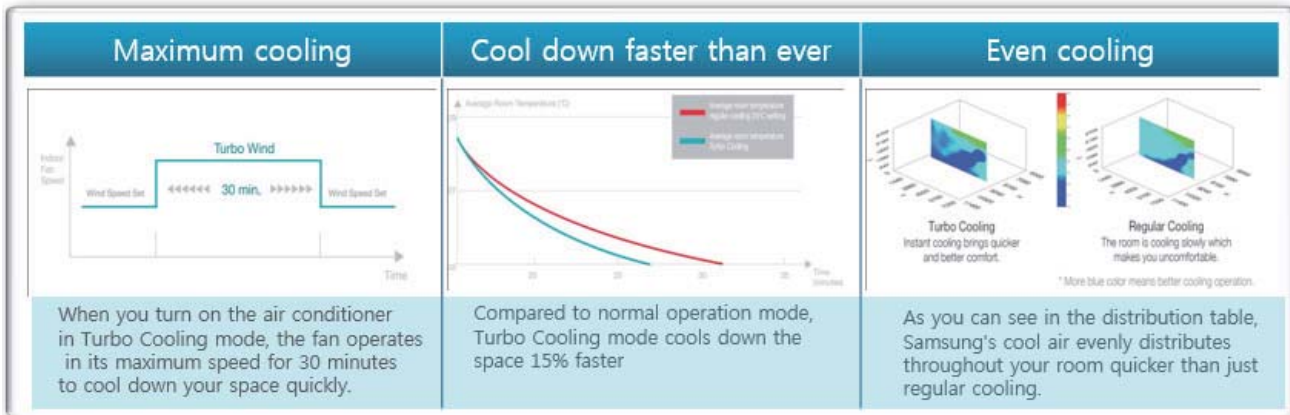

Good sleep

The quality of sleep you get directly impacts your physical and mental health. Concerned with your health, Samsung performed extensive experiments to determine the ideal temperatures needed to quickly fall asleep.

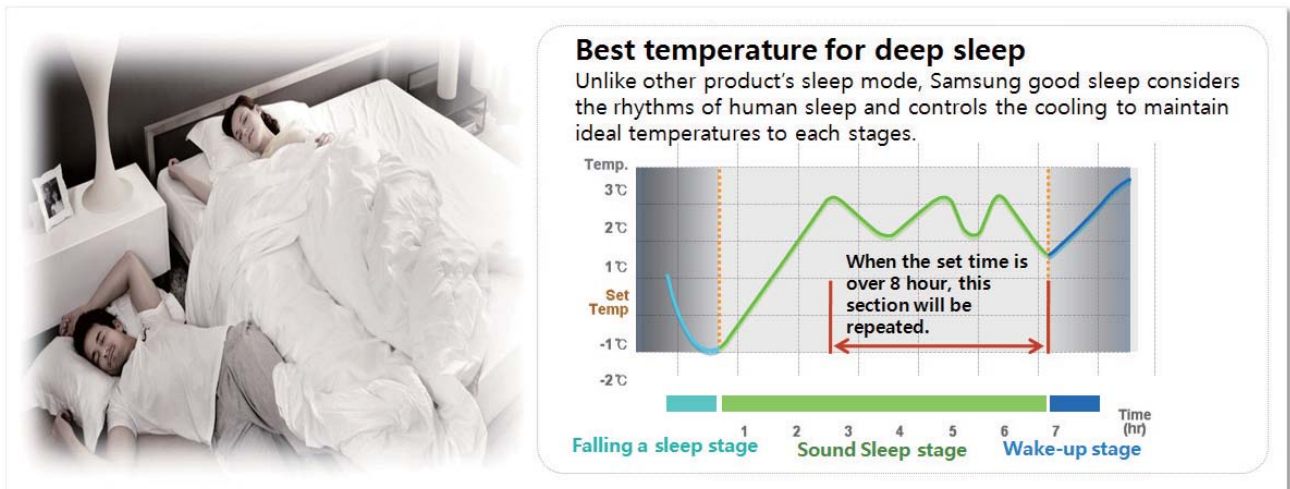

1. Specification

Wall Mounted Type

Model Name		Indoor Unit		AC018BNADCH/AA		AC024BNADCH/AA		
US Code		Outdoor Unit		AC018BXSCCC/AA		AC024BXSCCC/AA		
Indoor Unit		Outdoor Unit		CNH18ADB		CNH24ADB		
Outdoor Unit		Outdoor Unit		CXC18SCB		CXC24SCB		
System	Mode			-	Cooling Only	Cooling Only		
	Performance	Capacity (Min/Std/Max)	Cooling	kW	1.17/5.28/5.86	1.76/7.03/7.91		
				Btu/h	4,000 / 18,000 / 20,000	6,000 / 24,000 / 27,000		
				US RT	0.33/1.50/1.67	0.50/2.00/2.25		
			Heating	kW	-	-		
				Btu/h	-	-		
				US RT	-	-		
	Power	Power Input (Min/Std/Max)	Cooling	kW	0.23 / 1.50 / 2.42	0.33 / 2.50 / 3.50		
			Heating		-	-		
		Current Input (Min/Std/Max)	Cooling	A	1.4 / 6.8 / 10.6	2.0 / 11.1 / 15.4		
			Heating		-	-		
		Current	MCA	A	11.8	18.4		
			MFA	A	15	25		
	Efficiency	EER	Cooling	-	3.52	2.81		
			Cooling(US)	(Btu/h)/W	12.00	9.6		
		COP	Heating	W/W	-	-		
		SEER	-	-	20	18.5		
		HSPF	-	-	-	-		
	Pipe Connections	Liquid Pipe		Type	Flare	Flare		
				Φ, mm(inch)	6.35 (1/4)	6.35 (1/4)		
		Gas Pipe		Type	Flare	Flare		
				Φ, mm(inch)	12.7 (1/2)	15.88 (5/8)		
		Heat Insulation			-	Both liquid and gas pipes		
		Pipe Length (ODU-IDU)	Standard	Max.	m (ft)	7.5 (24.6)	7.5 (24.6)	
					m (ft)	30 (98.4)	50 (164.0)	
					Elevation	m (ft)	20 (65.6)	30 (98.4)
	Chargeless				m (ft)	7.5 (24.6)	7.5 (24.6)	
	Wiring Connections	Communication	Min.	mm ²	0.75	0.75		
			Remark	-	F1,F2	F1,F2		
	Refrigerant	Type		-	R410A	R410A		
Factory Charging		kg	1.3	2				
Option Code	Standard		-	0112FF-19542B-2A343B-371440	0112FF-19345E-27484F-371540			
	Install		-	020010-100011-200000-300000	020010-100041-200000-300000			
Indoor Unit	Power Supply			Φ,#,V,Hz	1,2,208-230,60	1,2,208-230,60		
	Heat Exchanger	Type		-	Fin & Tube	Fin & Tube		
		Material	Fin	-	Al	Al		
			Tube	-	Cu	Cu		
	Fin Treatment			-	Green Hydrophile	Green Hydrophile		
	Fan	Type		-	Cross flow	Cross flow		
		Quantity		EA	1	1		
		Air Flow Rate	H/M/L	m ³ /min	17.4/15.3/12.5	17.8/15.2/13.2		
				ft ³ /min	614/540/441	629/537/466		
				l/s	290/255/208	297/253/220		
	External Static Pressure	Min/Std/Max	In Wg	-	-			
	Fan Motor	Type		-	BLDC	BLDC		
		Output		W x n	27 x 1	27 x 1		
	Drain	Drain Pipe		Φ, mm	ID18	ID18		
	Sound	Sound Pressure Level	H/M/L(Silent)	dB(A)	42/37/32/29	44/39/35/30		
		Sound Power Level		dB(A)	60	61		
	External Dimension	Net Weight		kg(lbs)	11.7 (25.8)	12.7 (28.0)		
		Gross Weight		kg(lbs)	13.5 (29.8)	14.7 (32.4)		
		Net Dimensions (WxHxD)	mm		1,055 x 215 x 299	1,055 x 215 x 299		
			inch		41.54 x 8.46 x 11.77	41.54 x 8.46 x 11.77		
Gross Dimensions (WxHxD)		mm		1,115 x 290 x 375	1,115 x 290 x 375			
		inch		43.90 x 11.42 x 14.76	43.90 x 11.42 x 14.76			

1. Specification

Wall Mounted Type

Model Name		Indoor Unit		AC018BNADCH/AA	AC024BNADCH/AA	
		Outdoor Unit		AC018BXSCCC/AA	AC024BXSCCC/AA	
US Code		Indoor Unit		CNH18ADB	CNH24ADB	
		Outdoor Unit		CXC18SCB	CXC24SCB	
Indoor Unit	Casing	Material	-	Plastic	Plastic	
	Control System	Infrared remote control	-	DB96-24901P	DB96-24901P	
		Wired remote control	-	MWR-WG00UN / MWR-SH11UN	MWR-WG00UN / MWR-SH11UN	
	Drain Pump	Drain Pump	-	-	-	
		Max.lifting Height / Displacement	in / gal/h	-	-	
Additional Accessories	Air Filter	-	Washable	Washable		
Outdoor Unit	Power Supply		Φ,#,V,Hz	1,2,208-230,60	1,2,208-230,60	
	Heat Exchanger	Type	-	Fin & Tube	Fin & Tube	
		Material	Fin	-	Al	Al
			Tube	-	Cu	Cu
	Fin Treatment		-	Anti-Corrosion	Anti-Corrosion	
	Compressor	Model		-	UG9TK3150FE4SG	UG4T200FUA4SG
		Type		-	Twin BLDC	Twin BLDC
		Output		kW	1.42	1.79
		Oil	Type	-	POE	POE
	Initial Charge		cc (fl oz)	500	650	
	Fan	Type		-	Propeller	Propeller
		Discharge direction		-	Front	Front
		Quantity		EA	1	1
		Air Flow Rate	H/M/L	m ³ /min	40	51
				ft ³ /min	1,413	1,801
	l/s			667	850	
	Fan Motor	Type		-	BLDC	BLDC
		Output		W x n	125 x 1	125 x 1
	Sound	Sound Pressure Level	Cooling	dB(A)	48	50
			Heating	dB(A)	-	-
		Sound Power Level		dB(A)	62	65
	External Dimension	Net Weight		kg(lbs)	40.5 (89.3)	52.5 (115.7)
		Gross Weight		kg(lbs)	43.5 (96.1)	56.5 (124.6)
Net Dimensions (WxHxD)		mm	880 x 638 x 310	880 x 798 x 310		
		inch	34.65 x 25.12 x 12.20	34.65 x 31.42 x 12.20		
Gross Dimensions (WxHxD)		mm	1,023 x 730 x 413	1,023 x 881 x 413		
		inch	40.28 x 28.74 x 16.26	40.28 x 34.69 x 16.26		
Casing	Material	Body	-	Steel	Steel	
		Operating Temp. Range		°C (°F)	-40~50 (-40~122)	-40~50 (-40~122)
	Heating		°C (°F)	-	-	

NOTE

- Specification may be subject to change without prior notice.
- 1) Performances are based on the following test conditions.
 - Cooling : Indoor temperature : 80°F(26.7°C) DB, 67°F(19.4°C) WB, Outdoor temperature : 95°F(35°C) DB, 75°F(23.9°C) WB
 - Heating : Indoor temperature : 70°F(21.1°C) DB, 60°F(15.6°C) WB, Outdoor temperature : 47°F(8.3°C) DB, 43°F(6.1°C) WB
 - Equivalent refrigerant piping length 5m(16.4ft), Level differences : 0m(0ft)
- 2) Select wire size based on the value of MCA
- 3) Sound pressure level is obtained in an anechoic room.
 - Sound pressure level is a relative value, depending on the distance and acoustic environment.
 - Sound pressure level may differ depending on operation condition.
 - dBA = A-weighted sound pressure level / Reference acoustic pressure 0 dB = 20uPa
- 4) Sound power level is an absolute value that a sound source generates.
 - dBA = A-weighted sound power level
 - Reference power : 1pW / Measured according to ISO 3741
- 5) These products contain R410A which is fluorinated greenhouse gas.

1. Specification

Wall Mounted Type

Model Name		Indoor Unit		AC030BNTDCH/AA		AC036BNTDCH/AA	
US Code		Outdoor Unit		AC030BXSCCC/AA		AC036BXSCCC/AA	
US Code		Indoor Unit		CNH30TDB		CNH36TDB	
US Code		Outdoor Unit		CXC30SCB		CXC36SCB	
System	Mode			-	Cooling Only	Cooling Only	
	Performance	Capacity (Min/Std/Max)	Cooling	kW	2.49/8.79/10.26	2.93/10.55/11.14	
				Btu/h	8,500 / 30,000 / 35,000	10,000 / 36,000 / 38,000	
				US RT	0.71/2.5/2.92	0.83/3.00/3.17	
			Heating	kW	-	-	
				Btu/h	-	-	
				US RT	-	-	
	Power	Power Input (Min/Std/Max)	Cooling	kW	0.50 / 2.94 / 4.60	0.60 / 4.44 / 4.80	
			Heating		-	-	
		Current Input (Min/Std/Max)	Cooling	A	3.3 / 13.0 / 20.2	4.1 / 19.5 / 21.1	
			Heating		-	-	
		Current	MCA	A	21.9	21.9	
			MFA	A	30	30	
	Efficiency	EER	Cooling	-	2.99	2.38	
			Cooling(US) (Btu/h)/W	10.2	8.1		
		COP	Heating	W/W	-	-	
		SEER	-	-	19.7	18	
		HSPF	-	-	-	-	
	Pipe Connections	Liquid Pipe		Type	Flare	Flare	
				Φ, mm(inch)	9.52 (3/8)	9.52 (3/8)	
		Gas Pipe		Type	Flare	Flare	
				Φ, mm(inch)	15.88 (5/8)	15.88 (5/8)	
		Heat Insulation			-	Both liquid and gas pipes	
		Pipe Length (ODU-IDU)	Standard	m (ft)	7.5 (24.6)	7.5 (24.6)	
				Max.	50 (164.0)	50 (164.0)	
	Chargeless		Elevation	m (ft)	30 (98.4)	30 (98.4)	
			m (ft)	7.5 (24.6)	7.5 (24.6)		
	Wiring Connections	Communication	Min.	mm ²	0.75	0.75	
Remark			-	F1,F2	F1,F2		
Refrigerant	Type		-	R410A	R410A		
	Factory Charging		kg	2.4	2.4		
Option Code	Standard		-	0113FF-193572-275A5E-371700	0113FF-194593-276975-371700		
	Install		-	020010-100000-200000-300000	020010-100000-200000-300000		
Indoor Unit	Power Supply			Φ,#,V,Hz	1,2,208-230,60	1,2,208-230,60	
	Heat Exchanger	Type		-	Fin & Tube	Fin & Tube	
		Material	Fin	-	Al	Al	
			Tube	-	Cu	Cu	
		Fin Treatment			-	Green Hydrophile	Green Hydrophile
	Fan	Type		-	Cross flow	Cross flow	
		Quantity		EA	2	2	
		Air Flow Rate	H/M/L	m ³ /min	22.0/20.5/19	23.5/21.3/19.8	
				ft ³ /min	777/724/671	830/752/699	
				l/s	367/342/317	392/355/330	
	External Static Pressure	Min/Std/Max	In Wg	-	-		
	Fan Motor	Type		-	BLDC	BLDC	
		Output		W x n	58 X 1	58 X 1	
	Drain	Drain Pipe		Φ, mm	ID18	ID18	
	Sound	Sound Pressure Level	H/M/L(Silent)	dB(A)	49/47/45/37	51/48/46/38	
		Sound Power Level		dB(A)	63	65	
	External Dimension	Net Weight		kg(lbs)	18.5 (40.8)	18.5 (40.8)	
		Gross Weight		kg(lbs)	22.0 (48.5)	22.0 (48.5)	
Net Dimensions (WxHxD)		mm		1,280 x 253 x 345	1,280 x 253 x 345		
		inch		50.39 x 9.96 x 13.58	50.39 x 9.96 x 13.58		
Gross Dimensions (WxHxD)		mm	1,352 x 326 x 420	1,352 x 326 x 420			
		inch	53.23 x 12.83 x 16.54	53.23 x 12.83 x 16.54			

1. Specification

Wall Mounted Type

Model Name		Indoor Unit		AC030BNTDCH/AA	AC036BNTDCH/AA	
		Outdoor Unit		AC030BXSCCC/AA	AC036BXSCCC/AA	
US Code		Indoor Unit		CNH30TDB	CNH36TDB	
		Outdoor Unit		CXC30SCB	CXC36SCB	
Indoor Unit	Casing	Material	-	Plastic	Plastic	
	Control System	Infrared remote control		-	DB96-24901P	
		Wired remote control		-	MWR-WG00UN / MWR-SH11UN	MWR-WG00UN / MWR-SH11UN
	Drain Pump	Drain Pump		-	-	
		Max.lifting Height / Displacement		in / gal/h	-	-
Additional Accessories	Air Filter		-	Washable	Washable	
Outdoor Unit	Power Supply		Φ,#,V,Hz	1,2,208-230,60	1,2,208-230,60	
	Heat Exchanger	Type		-	Fin & Tube	Fin & Tube
		Material	Fin	-	Al	Al
			Tube	-	Cu	Cu
	Fin Treatment		-	Anti-Corrosion	Anti-Corrosion	
	Compressor	Model		-	UG8T300FUBJUSG	UG8T300FUBJUSG
		Type		-	Twin BLDC	Twin BLDC
		Output		kW	2.82	2.82
		Oil	Type	-	POE	POE
	Initial Charge		cc (fl oz)	1200	1200	
	Fan	Type		-	Propeller	Propeller
		Discharge direction		-	Front	Front
		Quantity		EA	1	1
		Air Flow Rate	H/M/L	m ³ /min	78	78
				ft ³ /min	2,755	2,755
	l/s			1,300	1,300	
	Fan Motor	Type		-	BLDC	BLDC
		Output		W x n	125 x 1	125 x 1
	Sound	Sound Pressure Level	Cooling	dB(A)	52	54
			Heating	dB(A)	-	-
		Sound Power Level		dB(A)	67	69
	External Dimension	Net Weight		kg(lbs)	71.0 (156.5)	71.0 (156.5)
		Gross Weight		kg(lbs)	76.0 (167.6)	76.0 (167.6)
Net Dimensions (WxHxD)		mm	940 x 998 x 330	940 x 998 x 330		
		inch	37.01 x 39.29 x 12.99	37.01 x 39.29 x 12.99		
Gross Dimensions (WxHxD)		mm	995 x 1,096 x 426	995 x 1,096 x 426		
		inch	39.17 x 43.15 x 16.77	39.17 x 43.15 x 16.77		
Casing	Material	Body	-	Steel	Steel	
	Operating Temp. Range	Cooling	°C (°F)	-40~50 (-40~122)	-40~50 (-40~122)	
Heating		°C (°F)	-	-		

NOTE

- Specification may be subject to change without prior notice.
 - 1) Performances are based on the following test conditions.
 - Cooling : Indoor temperature : 80°F(26.7°C) DB, 67°F(19.4°C) WB, Outdoor temperature : 95°F(35°C) DB, 75°F(23.9°C) WB
 - Heating : Indoor temperature : 70°F(21.1°C) DB, 60°F(15.6°C) WB, Outdoor temperature : 47°F(8.3°C) DB, 43°F(6.1°C) WB
 - Equivalent refrigerant piping length 5m(16.4ft), Level differences : 0m(0ft)
 - 2) Select wire size based on the value of MCA
 - 3) Sound pressure level is obtained in an anechoic room.
 - Sound pressure level is a relative value, depending on the distance and acoustic environment.
 - Sound pressure level may differ depending on operation condition.
 - dBA = A-weighted sound pressure level / Reference acoustic pressure 0 dB = 20uPa
 - 4) Sound power level is an absolute value that a sound source generates.
 - dBA = A-weighted sound power level
 - Reference power : 1pW / Measured according to ISO 3741
 - 5) These products contain R410A which is fluorinated greenhouse gas.

2. Summary Table

Wall Mounted Type

Performance Characteristics

Model Code	Net Weight (lbs)	Capacity		Fan Speed	Airflow (Cooling/Heating) (CFM)	Sound Pressure Level (dBA)	Sound Power Level (dBA)	
		Cooling (Btu/h)	Heating (Btu/h)					
CNH18ADB (AC018BNADCH/AA)	25.8	Max.	20,000	-	High	614 / -	42	60
		Std.	18,000	-	Mid	540 / -	37	-
		Min.	4,000	-	Low	441 / -	32	-
CNH24ADB (AC024BNADCH/AA)	28.0	Max.	27,000	-	High	629 / -	44	61
		Std.	24,000	-	Mid	537 / -	39	-
		Min.	6,000	-	Low	466 / -	35	-
CNH30TDB (AC030BNTDCH/AA)	40.8	Max.	35,000	-	High	777 / -	49	63
		Std.	30,000	-	Mid	724 / -	47	-
		Min.	8,500	-	Low	670 / -	45	-
CNH36TDB (AC036BNTDCH/AA)	40.8	Max.	38,000	-	High	830 / -	51	65
		Std.	36,000	-	Mid	752 / -	48	-
		Min.	10,000	-	Low	699 / -	46	-

NOTE

- Sound data is based on cooling operation.

Electric Characteristics

Model		Outdoor Unit				Input Current (Amperes)			Power Supply		
Indoor Unit	Outdoor Unit	Rated	Voltage range		Outdoor Unit		Indoor Unit	Total	MCA(A)	MOP(A)	
		Hz	Voltz	Min.	Max	Cooling					Heating
CNH18ADB (AC018BNADCH/AA)	CXC18SCB (AC018BXSCCC/AA)	60	208 to 230	187	253	11.33	-	0.42	11.75	11.8	15
CNH24ADB (AC024BNADCH/AA)	CXC24SCB (AC024BXSCCC/AA)	60	208 to 230	187	253	17.95	-	0.42	18.37	18.4	25
CNH30TDB (AC030BNTDCH/AA)	CXC30SCB (AC030BXSCCC/AA)	60	208 to 230	187	253	21.33	-	0.51	21.84	21.9	30
CNH36TDB (AC036BNTDCH/AA)	CXC36SCB (AC036BXSCCC/AA)	60	208 to 230	187	253	21.33	-	0.51	21.84	21.9	30

NOTE

- MCA : Minimum circuit amperes
- MOP : Maximum Overcurrent Protective Device
- Select wire size based on the value of MCA

3. Capacity Table

Wall Mounted Type

(1) CNH18ADB(AC018BNADCH/AA)+CXC18SCB(AC018BXSCCC/AA)

Cooling

TC : Total Capacity, SHC : Sensible Heat Capacity, PI : Power Input

Outdoor Temp. (°F, DB)	Indoor Temperature (°F, DB / WB)																							
	68 / 57			72 / 61			77 / 64			80 / 67			82 / 70			86 / 72			90 / 75					
	TC	SHC	PI	TC	SHC	PI	TC	SHC	PI	TC	SHC	PI	TC	SHC	PI	TC	SHC	PI	TC	SHC	PI			
	MBH	MBH	kW	MBH	MBH	kW	MBH	MBH	kW	MBH	MBH	kW	MBH	MBH	kW	MBH	MBH	kW	MBH	MBH	kW	MBH	MBH	kW
-40	22.3	16.1	1.27	23.5	16.6	1.30	24.4	17.1	1.32	25.2	17.6	1.35	25.7	17.5	1.36	27.0	17.3	1.38	28.3	16.9	1.40			
0	19.1	13.8	1.41	20.1	14.2	1.44	21.0	14.7	1.47	21.6	15.1	1.50	22.0	15.0	1.52	23.1	14.8	1.53	24.3	14.5	1.56			
70	20.7	14.9	1.55	21.8	15.4	1.58	22.7	15.9	1.62	23.4	16.4	1.65	23.9	16.2	1.67	25.1	16.1	1.68	26.3	15.7	1.72			
95	15.9	11.5	1.41	16.8	11.9	1.44	17.5	12.2	1.47	18.0	12.6	1.50	18.4	12.5	1.52	19.3	12.3	1.53	20.2	12.1	1.56			
115	15.9	13.1	2.12	16.8	13.5	2.16	17.5	14.0	2.21	18.0	14.4	2.25	18.4	14.3	2.27	19.3	14.1	2.30	20.2	13.8	2.34			
122	11.1	10.3	1.62	11.7	10.7	1.66	12.2	11.0	1.69	12.6	11.3	1.73	12.9	11.2	1.74	13.5	11.1	1.76	14.2	10.9	1.79			

(2) CNH24ADB(AC024BNADCH/AA)+CXC24SCB(AC024BXSCCC/AA)

Cooling

TC : Total Capacity, SHC : Sensible Heat Capacity, PI : Power Input

Outdoor Temp. (°F, DB)	Indoor Temperature (°F, DB / WB)																							
	68 / 57			72 / 61			77 / 64			80 / 67			82 / 70			86 / 72			90 / 75					
	TC	SHC	PI	TC	SHC	PI	TC	SHC	PI	TC	SHC	PI	TC	SHC	PI	TC	SHC	PI	TC	SHC	PI			
	MBH	MBH	kW	MBH	MBH	kW	MBH	MBH	kW	MBH	MBH	kW	MBH	MBH	kW	MBH	MBH	kW	MBH	MBH	kW	MBH	MBH	kW
-40	24.4	18.9	1.88	25.7	19.5	1.92	26.8	20.1	1.96	27.6	20.7	2.00	28.2	20.5	2.02	29.6	20.3	2.04	31.0	19.9	2.08			
0	22.3	17.2	1.65	23.5	17.8	1.68	24.4	18.3	1.72	25.2	18.9	1.75	25.7	18.7	1.77	27.0	18.5	1.79	28.3	18.2	1.82			
70	26.5	20.5	2.24	27.9	21.2	2.28	29.1	21.8	2.33	30.0	22.5	2.38	30.6	22.3	2.40	32.1	22.1	2.42	33.7	21.6	2.47			
95	21.2	15.3	2.35	22.3	15.8	2.40	23.3	16.3	2.45	24.0	16.8	2.50	24.5	16.6	2.53	25.7	16.5	2.55	27.0	16.1	2.60			
115	18.0	14.9	3.06	19.0	15.4	3.12	19.8	15.8	3.19	20.4	16.3	3.25	20.8	16.2	3.28	21.8	16.0	3.32	22.9	15.7	3.38			
122	15.9	14.0	2.94	16.8	14.4	3.00	17.5	14.8	3.06	18.0	15.3	3.13	18.4	15.1	3.16	19.3	15.0	3.19	20.2	14.7	3.25			

NOTE

- The performance table shows the average value of each conditions.

3. Capacity Table

Wall Mounted Type

(3) CNH30TDB(AC030BNTDCH/AA)+CXC30SCB(AC030BXSCCC/AA)

Cooling

TC : Total Capacity, SHC : Sensible Heat Capacity, PI : Power Input

Outdoor Temp. (°F, DB)	Indoor Temperature (°F, DB / WB)																				
	68 / 57			72 / 61			77 / 64			80 / 67			82 / 70			86 / 72			90 / 75		
	TC	SHC	PI	TC	SHC	PI	TC	SHC	PI	TC	SHC	PI	TC	SHC	PI	TC	SHC	PI	TC	SHC	PI
-40	29.2	22.6	3.04	30.7	23.3	3.11	32.0	24.0	3.17	33.0	24.8	3.23	33.7	24.5	3.27	35.3	24.3	3.30	37.1	23.8	3.36
0	30.5	23.6	3.04	32.1	24.3	3.11	33.5	25.1	3.17	34.5	25.9	3.23	35.2	25.6	3.27	36.9	25.4	3.30	38.8	24.9	3.36
70	31.8	24.6	2.63	33.5	25.4	2.68	34.9	26.2	2.74	36.0	27.0	2.79	36.7	26.7	2.82	38.6	26.5	2.85	40.5	25.9	2.91
95	26.5	20.5	2.77	27.9	21.2	2.82	29.1	21.8	2.88	30.0	22.5	2.94	30.6	22.3	2.97	32.1	22.1	3.00	33.7	21.6	3.06
115	19.9	18.5	3.04	21.0	19.1	3.11	21.8	19.6	3.17	22.5	20.3	3.23	23.0	20.0	3.27	24.1	19.8	3.30	25.3	19.5	3.36
122	18.6	17.2	2.91	19.6	17.8	2.96	20.4	18.3	3.03	21.0	18.9	3.09	21.4	18.7	3.12	22.5	18.5	3.15	23.6	18.2	3.21

(4) CNH36TDB(AC036BNTDCH/AA)+CXC36SCB(AC036BXSCCC/AA)

Cooling

TC : Total Capacity, SHC : Sensible Heat Capacity, PI : Power Input

Outdoor Temp. (°F, DB)	Indoor Temperature (°F, DB / WB)																				
	68 / 57			72 / 61			77 / 64			80 / 67			82 / 70			86 / 72			90 / 75		
	TC	SHC	PI	TC	SHC	PI	TC	SHC	PI	TC	SHC	PI	TC	SHC	PI	TC	SHC	PI	TC	SHC	PI
-40	35.0	27.1	4.60	36.9	27.9	4.69	38.4	28.8	4.79	39.6	29.7	4.88	40.4	29.4	4.93	42.4	29.1	4.98	44.5	28.5	5.08
0	36.6	28.3	4.60	38.6	29.2	4.69	40.2	30.1	4.79	41.4	31.1	4.88	42.2	30.7	4.93	44.3	30.4	4.98	46.6	29.8	5.08
70	38.2	29.6	3.97	40.2	30.5	4.05	41.9	31.4	4.13	43.2	32.4	4.22	44.1	32.1	4.26	46.3	31.8	4.30	48.6	31.1	4.39
95	31.8	24.6	4.18	33.5	25.4	4.26	34.9	26.2	4.35	36.0	27.0	4.44	36.7	26.7	4.48	38.6	26.5	4.53	40.5	25.9	4.62
115	23.9	22.2	4.60	25.1	22.9	4.69	26.2	23.6	4.79	27.0	24.3	4.88	27.5	24.1	4.93	28.9	23.8	4.98	30.4	23.3	5.08
122	22.3	20.7	4.39	23.5	21.3	4.48	24.4	22.0	4.57	25.2	22.7	4.66	25.7	22.5	4.71	27.0	22.2	4.76	28.3	21.8	4.85

NOTE

- The performance table shows the average value of each conditions.

4. Dimensional Drawing

Wall Mounted Type

CNH18ADB (AC018BNADCH/AA), CNH24ADB (AC024BNADCH/AA)

Units : mm [inches]

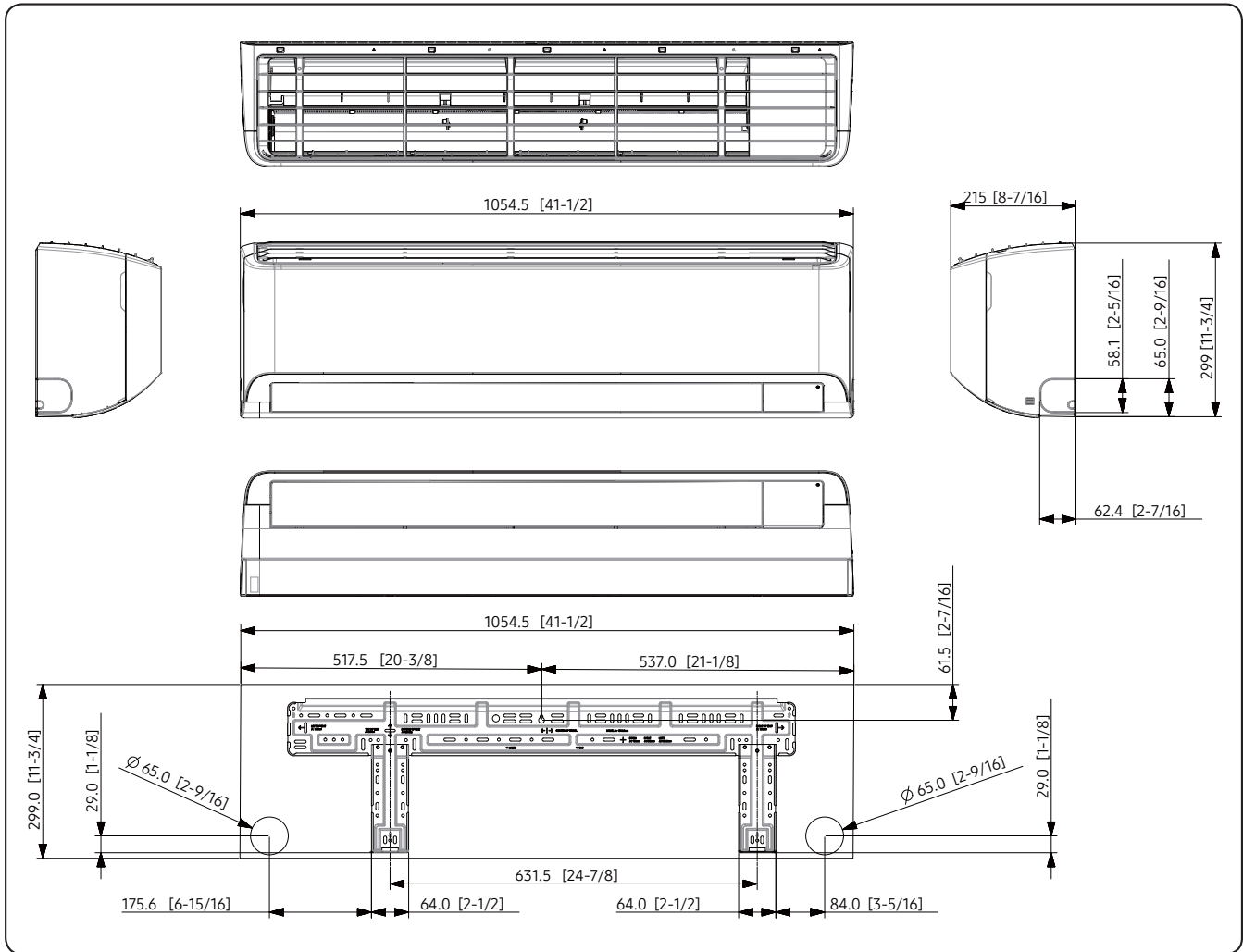

4. Dimensional Drawing

Wall Mounted Type

CNH30TDB (AC030BNTDCH/AA), CNH36TDB (AC036BNTDCH/AA)

Units : mm [inches]

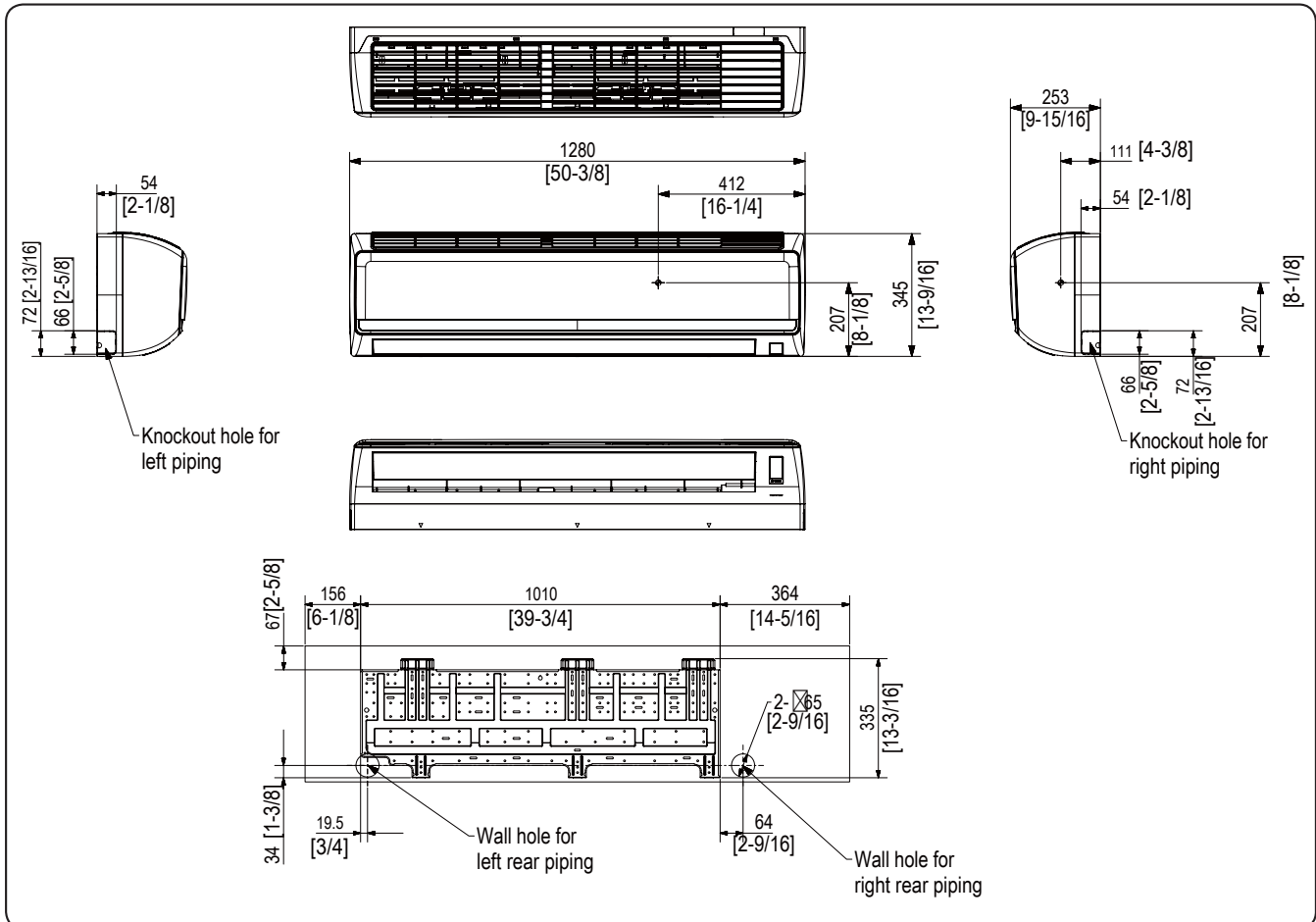

5. Center of Gravity

Wall Mounted Type

CNH18ADB (AC018BNADCH/AA), CNH24ADB (AC024BNADCH/AA)

Units : mm [inches]

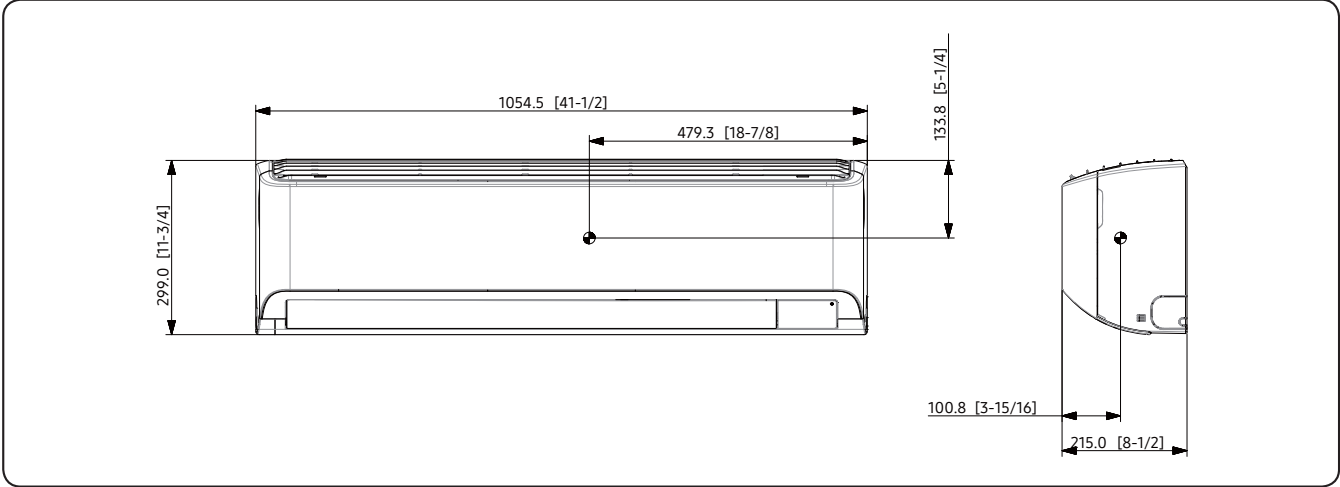

CNH30TDB (AC030BNTDCH/AA), CNH36TDB (AC036BNTDCH/AA)

Units : mm [inches]

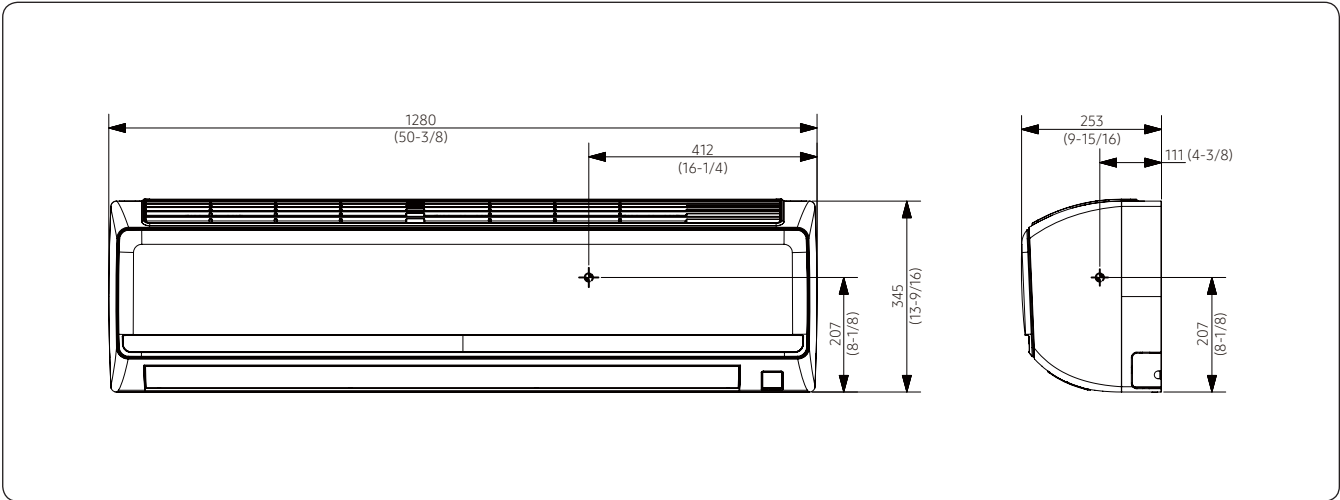

6. Electrical Wiring Diagram

Wall Mounted Type

CNH18ADB (AC018BNADCH/AA), CNH24ADB (AC024BNADCH/AA)

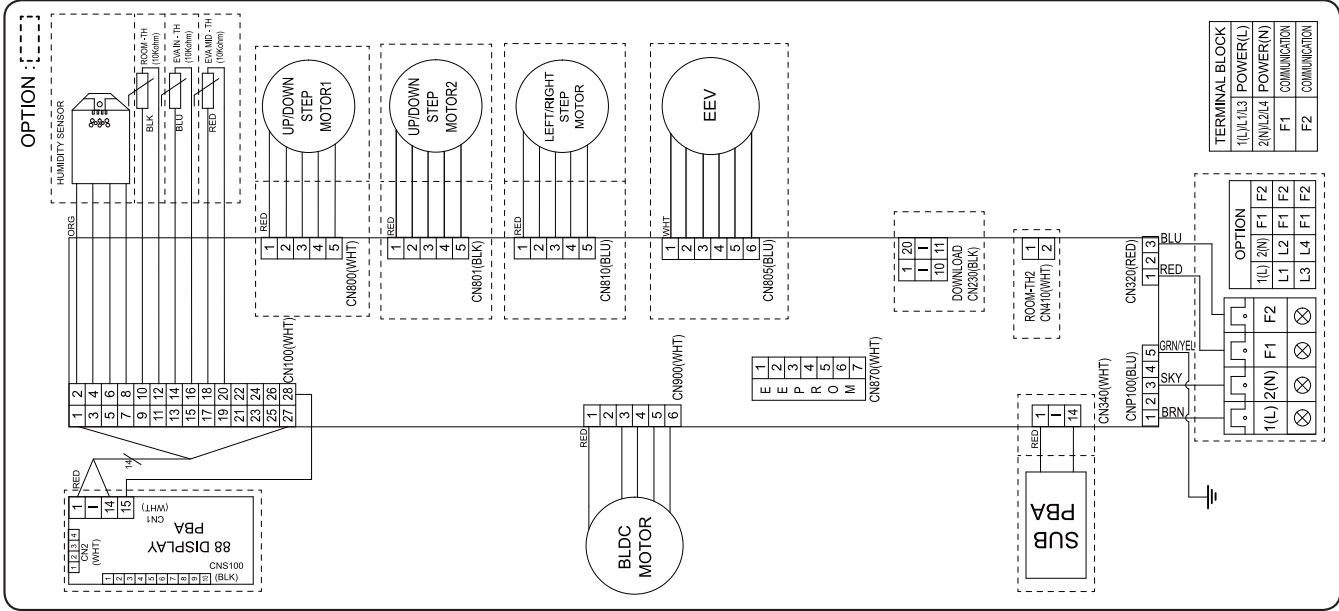

MAIN PBA	Printed circuit board(MAIN)	ROOM(10K)	Thermistor ROOM
SUB PBA	Printed circuit board(SUB)	EVA-IN(10K)	Thermistor EVA IN
88 DISPLAY PBA	Printed circuit board(DISPLAY)	EVA-MID(10K)	Thermistor EVA OUT
		ROOM2(10K)	External Thermistor ROOM((Option)

NOTE

- This wiring diagram applies only to the Indoor unit.
- Symbols show as follow :
blk: black, red: red, blu: blue, wht: white, yel: yellow, brn: brown, sky: skyblue: grn: green
- For connection wiring indoor-outdoor transmission F1-F2, indoor-wired remote controller transmission F3-F4.
- Protective earth(screw)

6. Electrical Wiring Diagram

Wall Mounted Type

CNH30TDB (AC030BNTDCH/AA), CNH36TDB (AC036BNTDCH/AA)

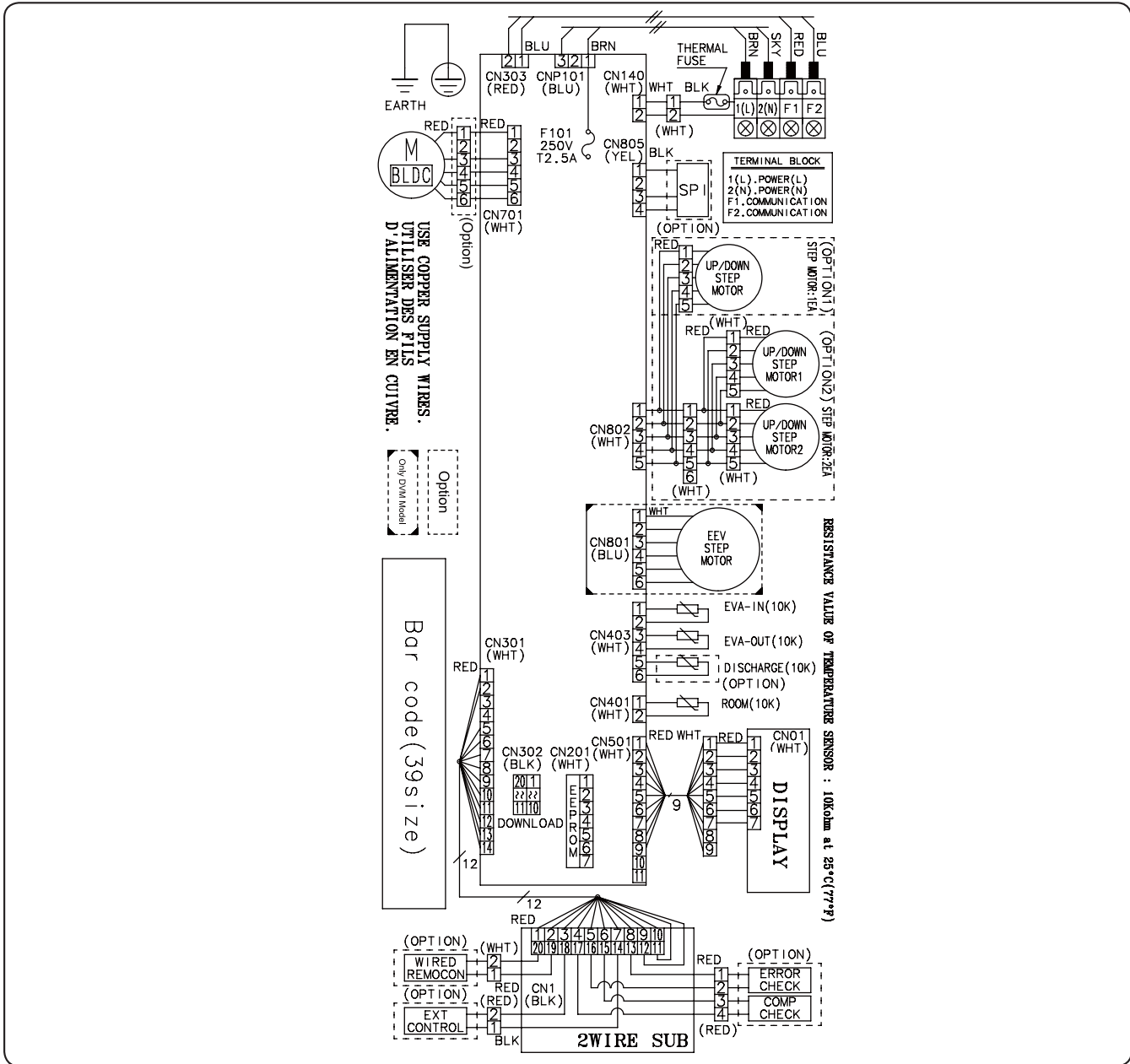

SPI	S-Plasma ion	EEV	Electronic Expansion Valve	ROOM	Thermistor ROOM in (10K)
M-BLDC	BLDC Motor	EVA-IN	Thermistor EVA IN(10K)	EVA-OUT	Thermistor EVA OUT(10K)

NOTE

- This wiring diagram applies only to the Indoor unit.
- Symbols show as follow : blk: black, red: red, blu: blue, wht: white, yel: yellow, brn: brown, sky: skyblue: grn: green
- For connection wiring indoor-outdoor transmission F1-F2, indoor-wired remotecontroller transmission F3-F4.
- Protective earth(screw)

7. Sound Data

Wall Mounted Type

Sound Pressure level

Unit: dB(A)

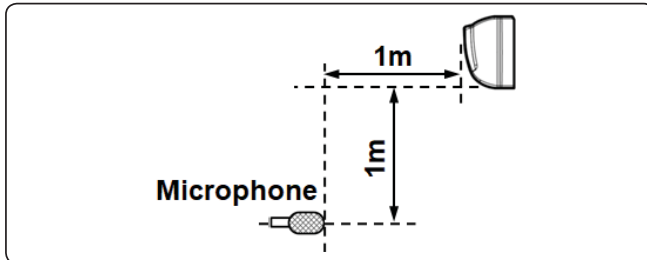

Model	High	Mid	Low	Silence
CNH18ADB (AC018BNADCH/AA)	42	37	32	29
CNH24ADB (AC024BNADCH/AA)	44	39	35	30
CNH30TDB (AC030BNTDCH/AA)	49	47	45	37
CNH36TDB (AC036BNTDCH/AA)	51	48	46	38

• NC Curve

1) CNH18ADB (AC018BNADCH/AA)

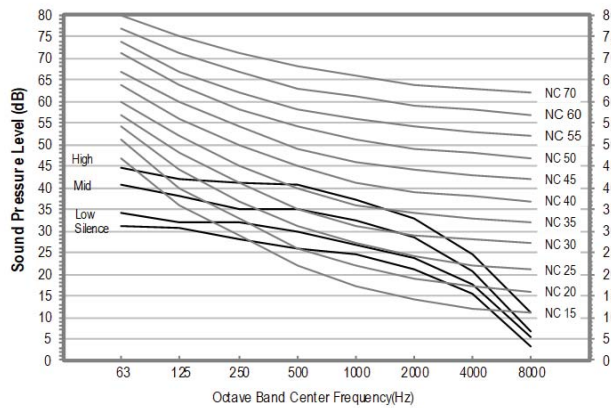

2) CNH24ADB (AC024BNADCH/AA)

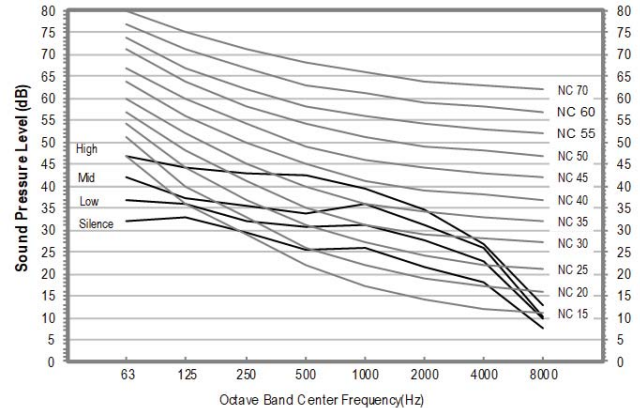

3) CNH30TDB (AC030BNTDCH/AA)

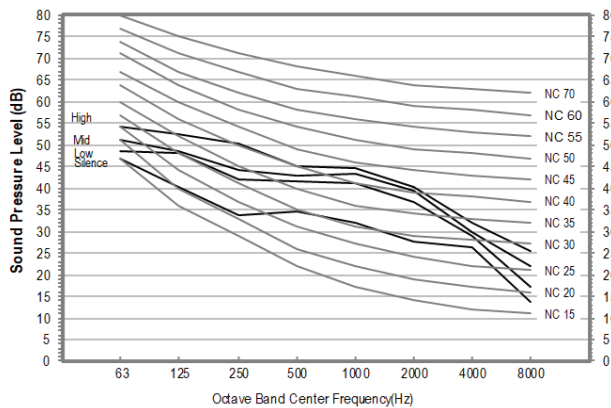

4) CNH36TDB (AC036BNTDCH/AA)

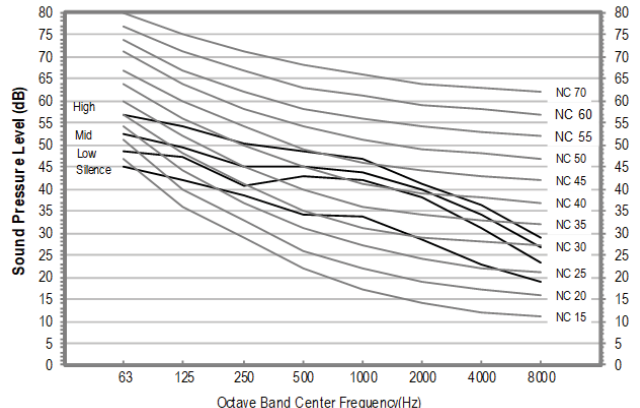

NOTE

- Specifications may be subject to change without prior notice.
 - Sound pressure level is obtained in an anechoic room.
 - Sound pressure level is a relative value, depending on the distance and acoustic environment.
 - Sound pressure level may differ depending on operation condition.
 - dBA = A weighted sound pressure level
 - Reference acoustic pressure 0 dB = 20μPa

7. Sound Data

Wall Mounted Type

Sound Power level

NOTE

Unit: dB(A)

- Specifications may be subject to change without prior notice
 - Sound power level is an absolute value that a sound source generates.
 - dBA = A-weighted sound power level.
 - Reference power : 1pW.
 - Measured according to ISO 3741.

Model	Cooling
CNH18ADB (AC018BNADCH/AA)	60
CNH24ADB (AC024BNADCH/AA)	61
CNH30TDB (AC030BNTDCH/AA)	63
CNH36TDB (AC036BNTDCH/AA)	65

- NC Curve

1) CNH18ADB (AC018BNADCH/AA)

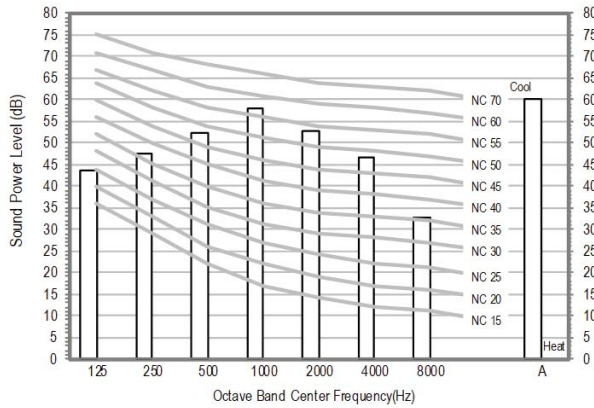

2) CNH24ADB (AC024BNADCH/AA)

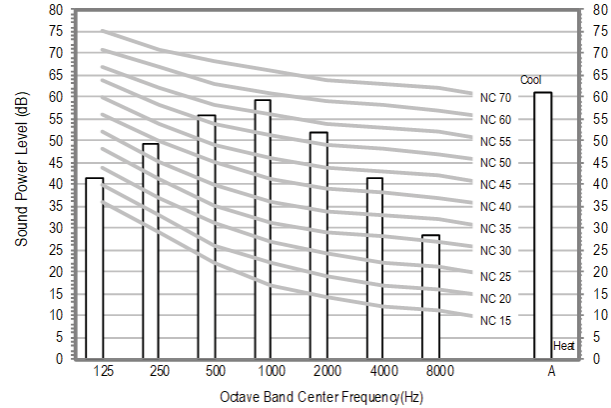

3) CNH30TDB (AC030BNTDCH/AA)

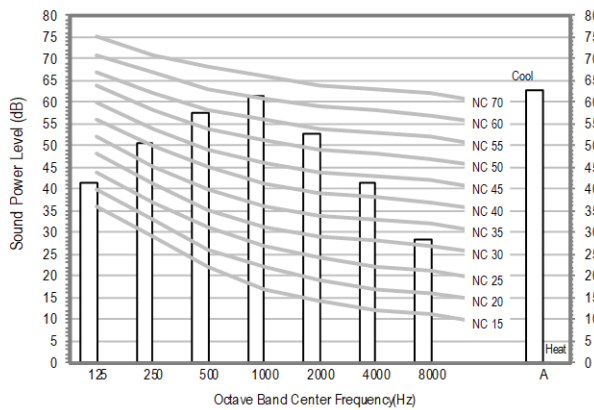

4) CNH36TDB (AC036BNTDCH/AA)

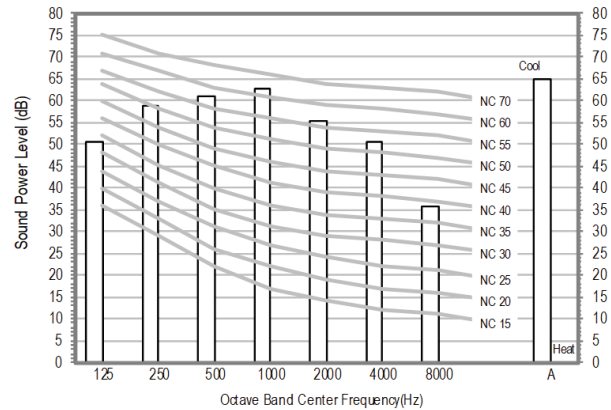

8. Temperature and air flow distribution

Wall Mounted Type

CNH18ADB (AC018BNADCH/AA)

- Cooling Air Velocity distribution
(Discharge angle : 20 degree)

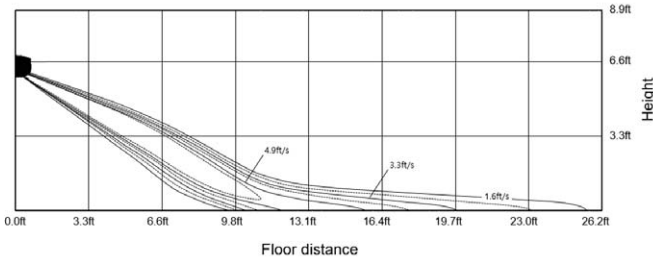

- Cooling temperature distribution
(Discharge angle : 20 degree)

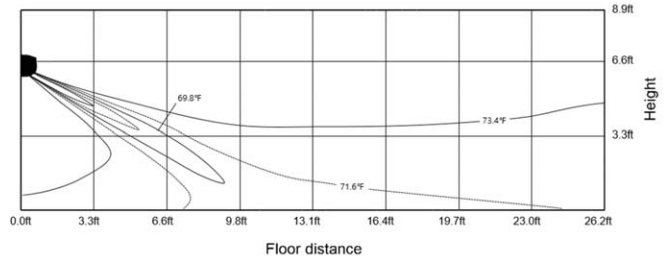

CNH24ADB (AC024BNADCH/AA)

- Cooling Air Velocity distribution
(Discharge angle : 20 degree)

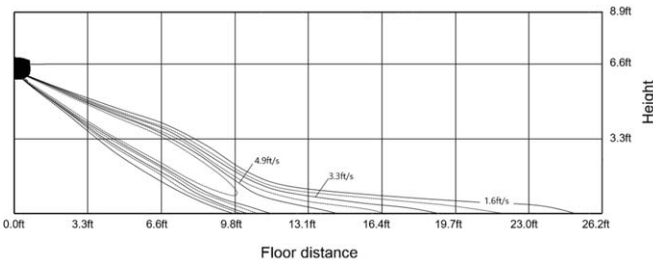

- Cooling temperature distribution
(Discharge angle : 20 degree)

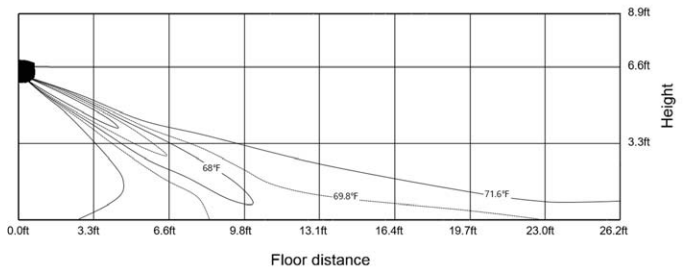

8. Temperature and air flow distribution

Wall Mounted Type

CNH30TDB (AC030BNTDCH/AA)

- Cooling Air Velocity distribution
(Discharge angle : 20 degree)

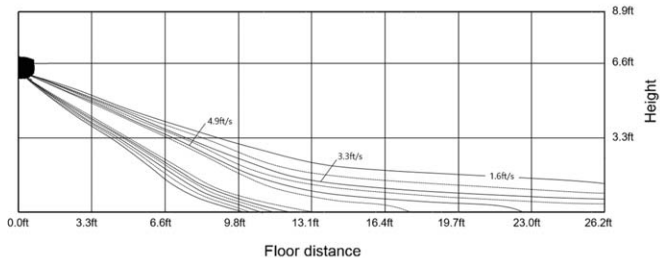

- Cooling temperature distribution
(Discharge angle : 20 degree)

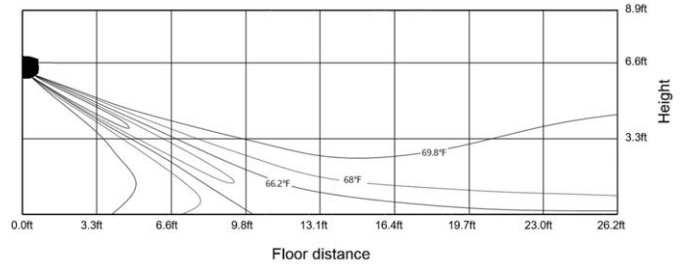

CNH36TDB (AC036BNTDCH/AA)

- Cooling Air Velocity distribution
(Discharge angle : 20 degree)

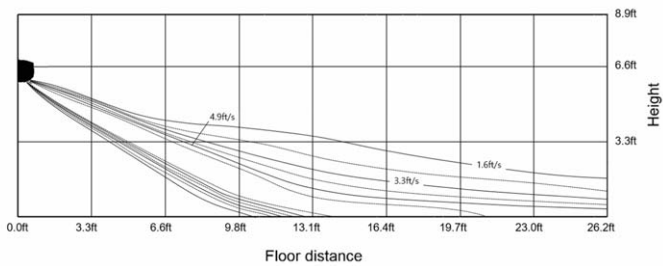

- Cooling temperature distribution
(Discharge angle : 20 degree)

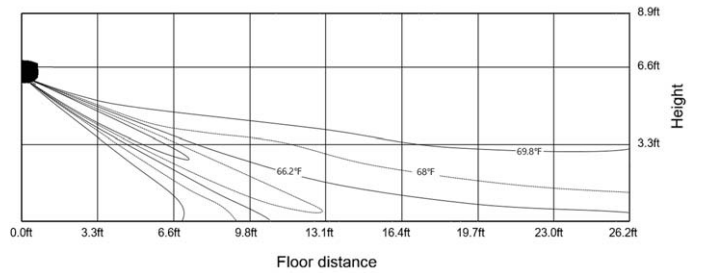

Outdoor Units

1. Summary Table	69
2. Dimensional Drawing	70
3. Center of Gravity	73
4. Electrical Wiring Diagram	75
5. Sound Data	77
6. Capacity Correction	79
7. Operation Range	82
8. Piping Diagram	83

1. Summary Table

Outdoor Units

Performance Characteristics

Capacity/ (Btu/h)	Model Code	Net Size (WxHxD inch)	Net Weight (lbs)	Airflow (CFM)	Sound Pressure Level (dBA)		Sound Power Level (dBA)
					Cooling	Heating	
18,000	CXC18SCB (AC018BXSCCC/AA)	34.65 x 25.12 x 12.20	89.3	1,413	48	-	62
24,000	CXC24SCB (AC024BXSCCC/AA)	34.65 x 31.42 x 12.20	115.7	1,801	50	-	65
30,000	CXC30SCB (AC030BXSCCC/AA)	37.01 x 39.29 x 12.99	156.5	2,755	52	-	67
36,000	CXC36SCB (AC036BXSCCC/AA)	37.01 x 39.29 x 12.99	156.5	2,755	54	-	69

NOTE

- Sound power level is based on cooling operation.

2. Dimensional Drawing

Outdoor Units

CXC18SCB (AC018BXSCCC/AA)

Units : mm [inches]

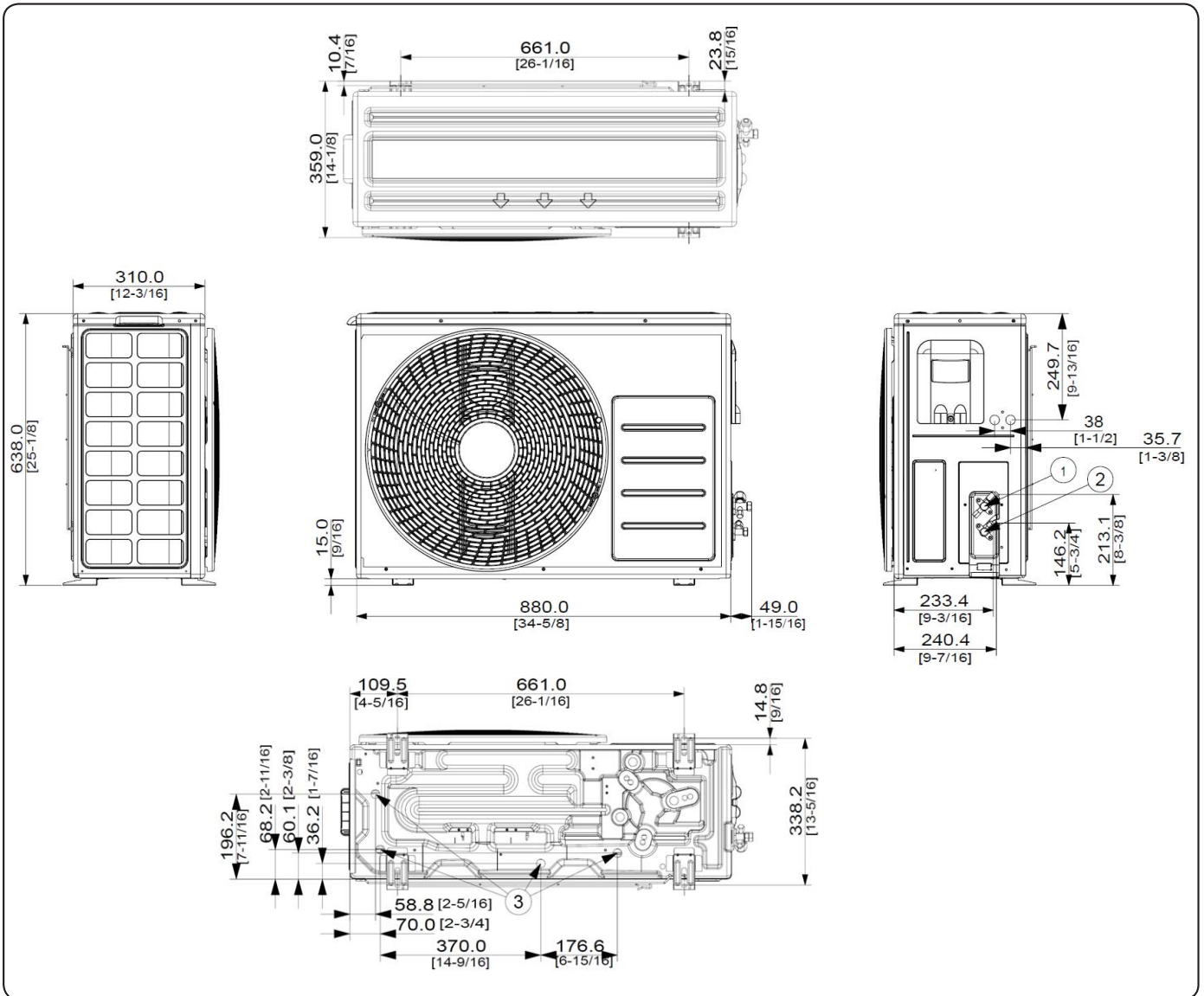

No.	Name	Description
1	Refrigerant liquid pipe	Φ 6.35mm(1/4")
2	Refrigerant gas pipe	Φ 12.7mm(1/2")
3	Drain hole	Connect with provided drain plug

2. Dimensional Drawing

Outdoor Units

CXC24SCB (AC024BXSCCC/AA)

Units : mm [inches]

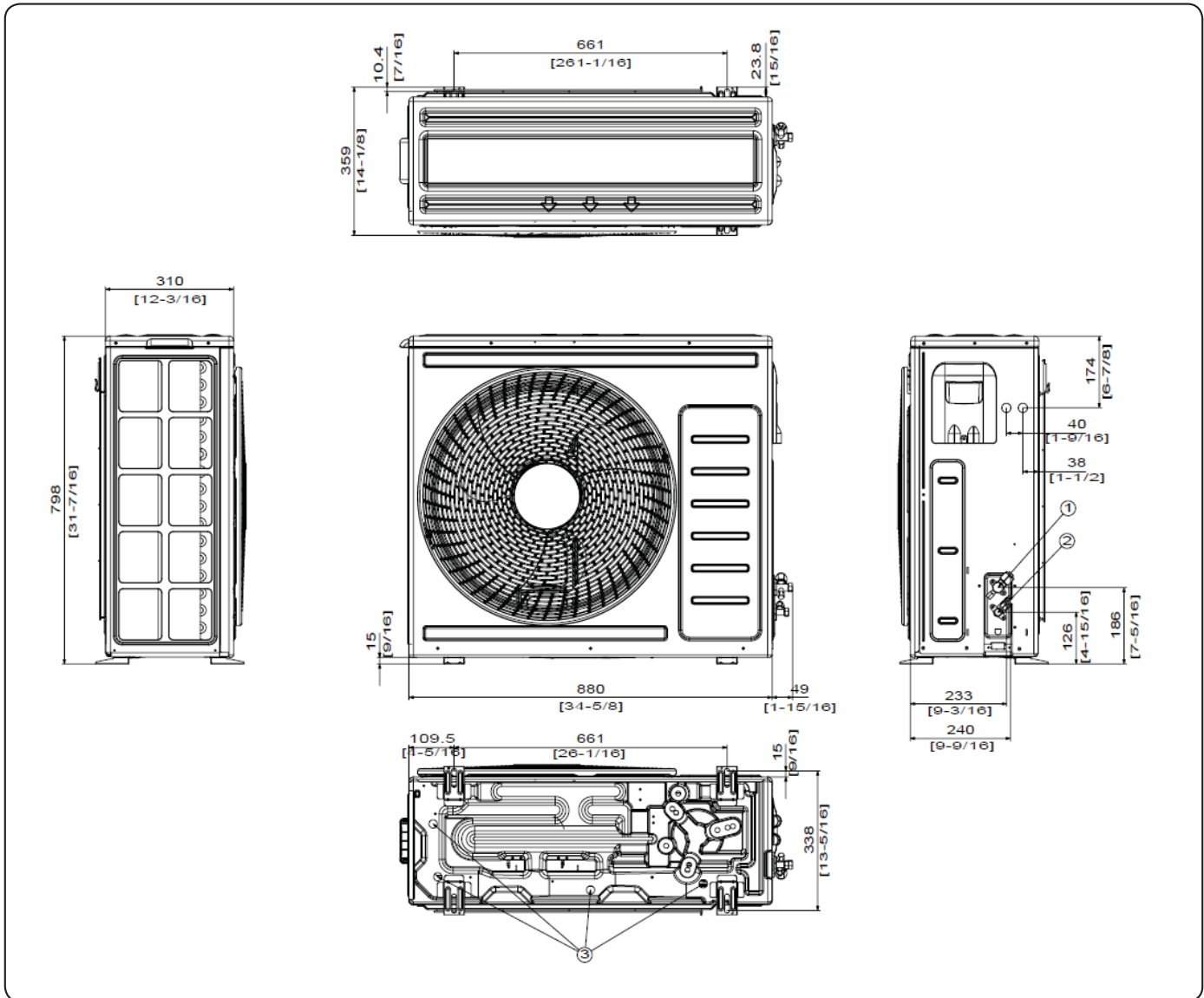

No.	Name	Description
1	Refrigerant liquid pipe	Φ 6.35mm(1/4")
2	Refrigerant gas pipe	Φ 15.88mm(5/8")
3	Drain hole	Connect with provided drain plug

2. Dimensional Drawing

Outdoor Units

CXC30SCB (AC030BXSCCC/AA), CXC36SCB (AC036BXSCCC/AA)

Units : mm [inches]

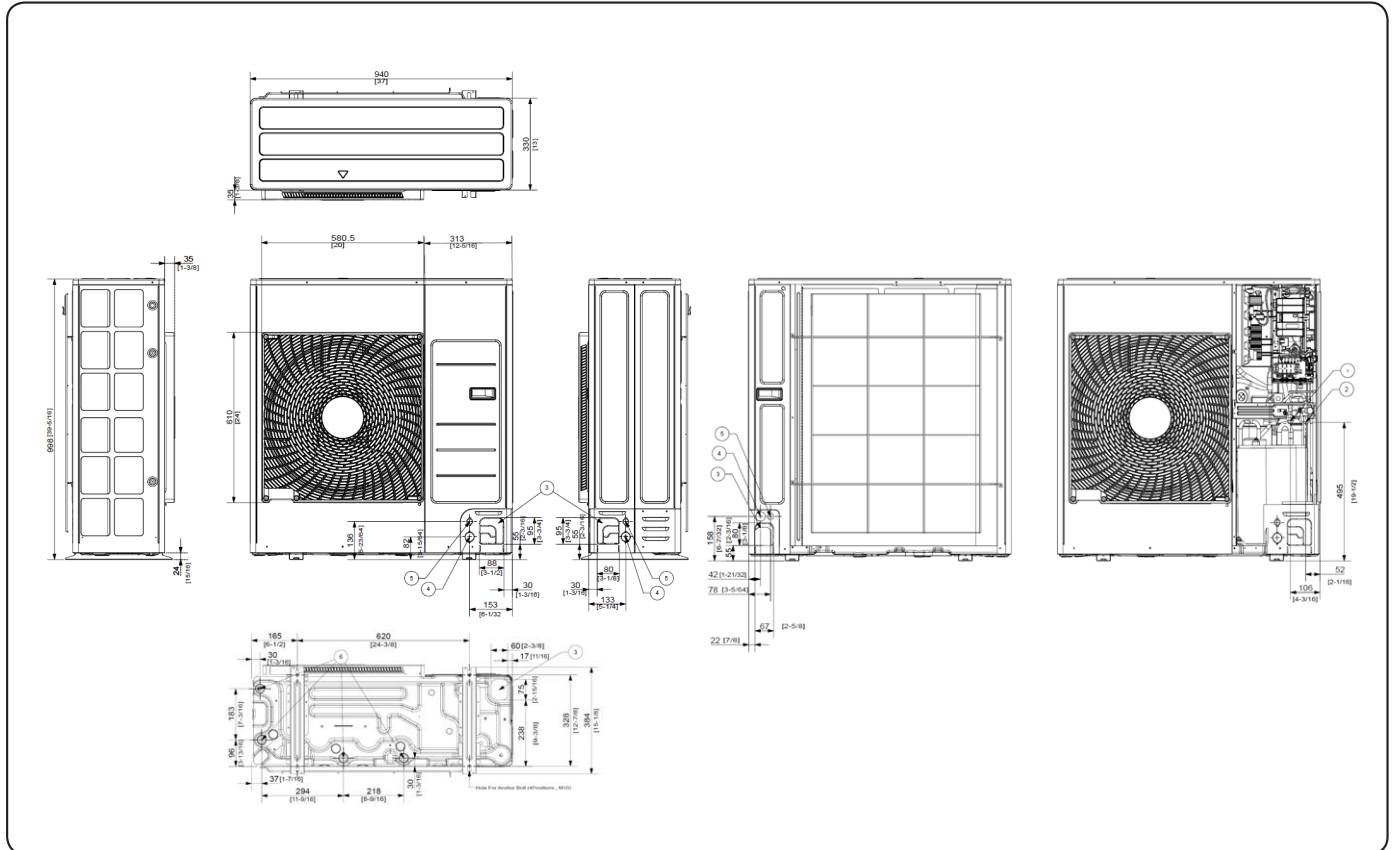

No.	Name	Description
1	Refrigerant liquid pipe	Φ 9.52mm(3/8")
2	Refrigerant gas pipe	Φ 15.88mm(5/8")
3	Piping intake knockout hole	Front / Side / Rear / Bottom
4	Power wiring conduit	Front / Side / Rear , Φ 34mm(1-3/8")
5	Communication wiring conduit	Front / Side / Rear , Φ 22mm(7/8")
6	Drain Hole	Connect with provided drain plug

3. Center of Gravity

Outdoor Units

CXC18SCB (AC018BXSCCC/AA)

Units : mm [inches]

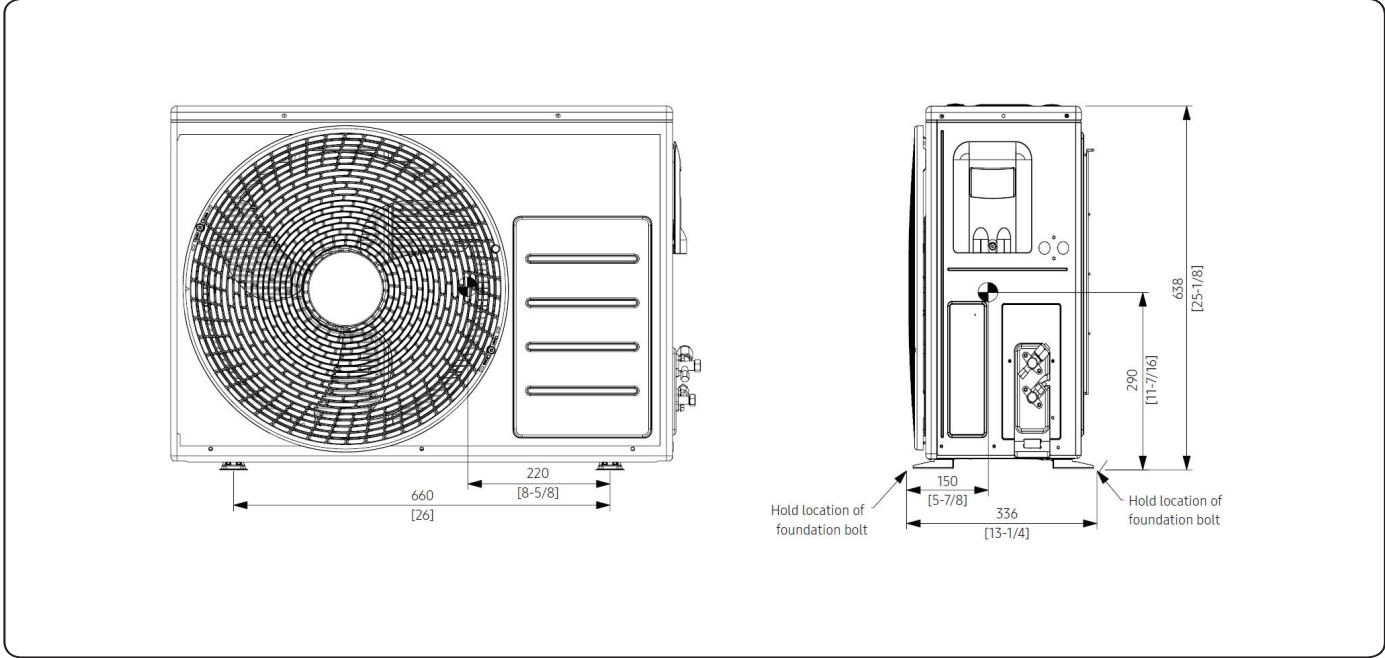

CXC24SCB (AC024BXSCCC/AA)

Units : mm [inches]

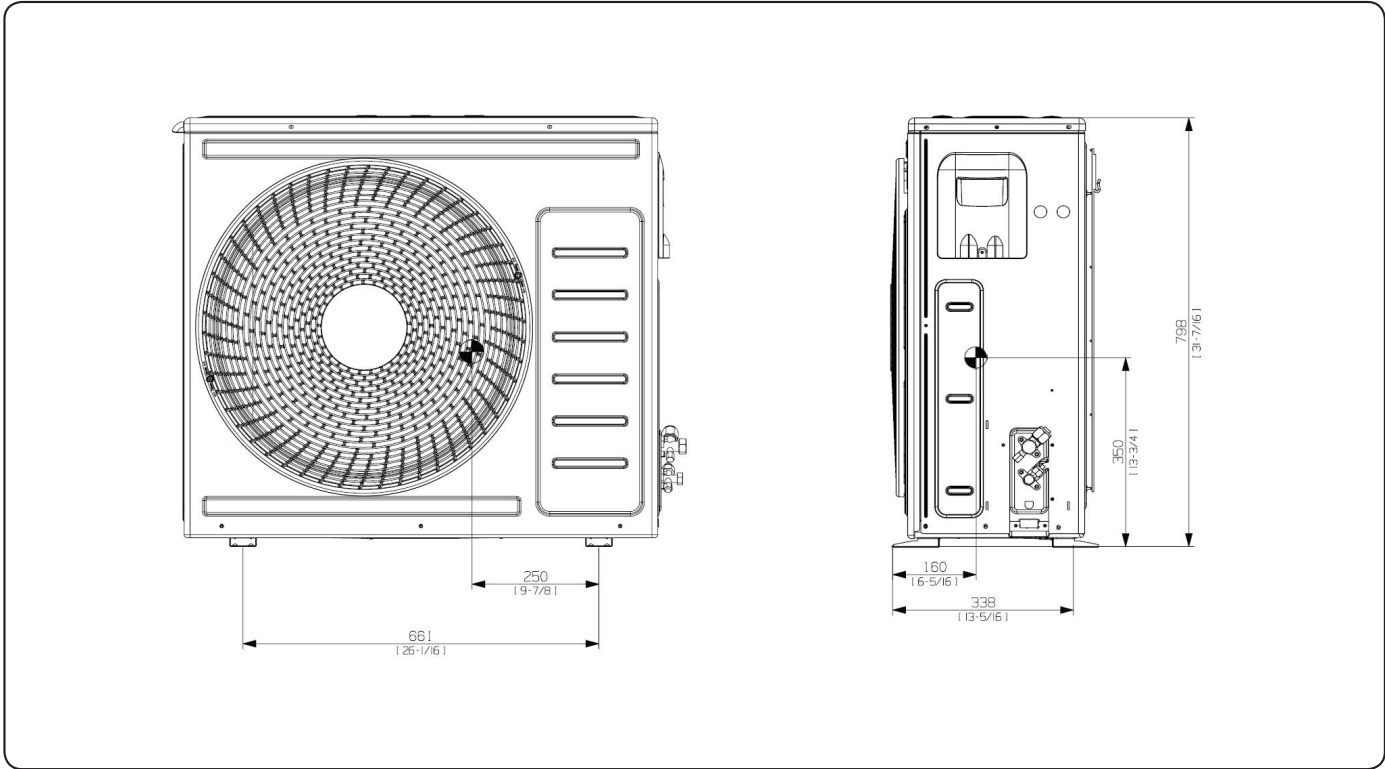

3. Center of Gravity

Outdoor Units

CXC30SCB (AC030BXSCCC/AA), CXC36SCB (AC036BXSCCC/AA)

Units : mm [inches]

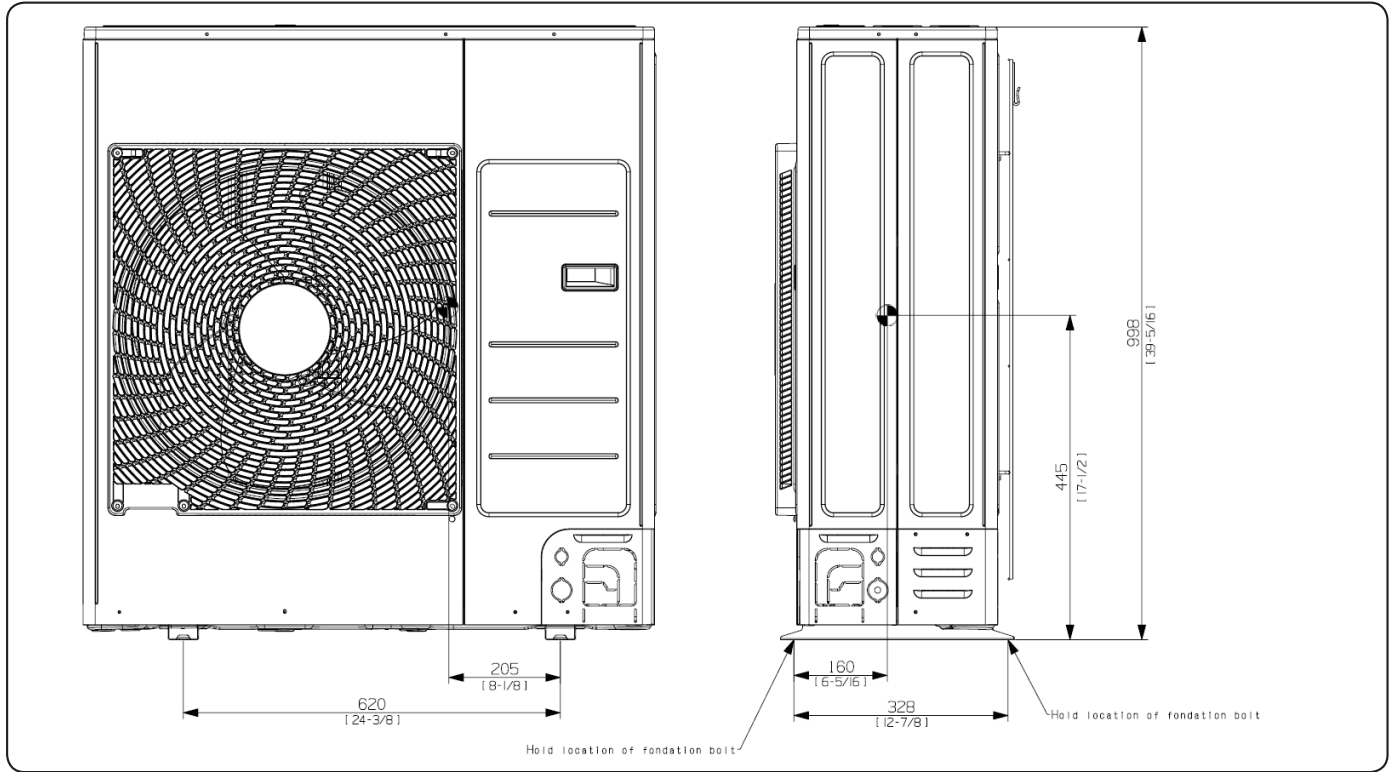

4. Electrical Wiring Diagram

Outdoor Units

CXC18SCB (AC018BXSCCC/AA), CXC24SCB (AC024BXSCCC/AA)

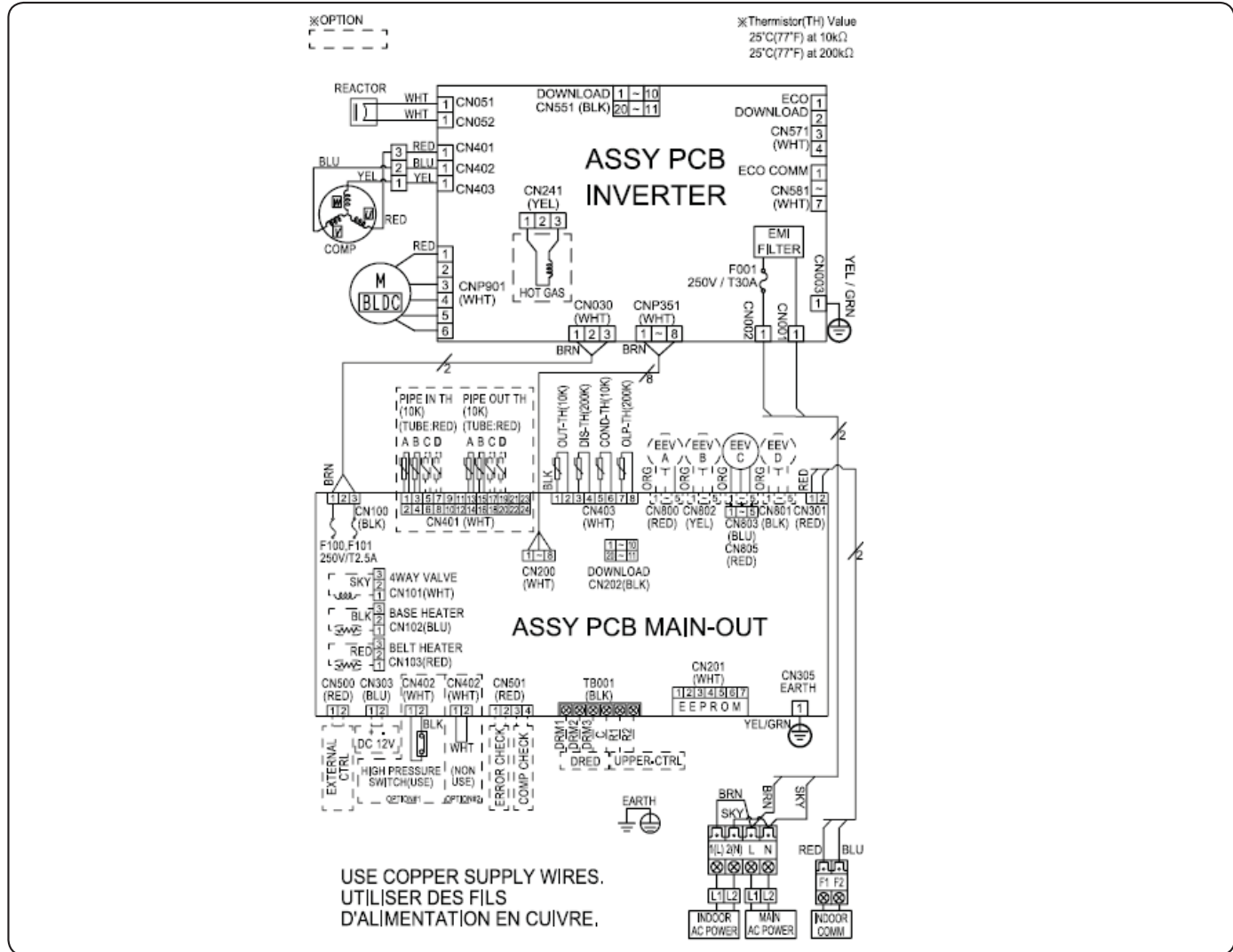

MAIN PCB	Printed circuit board(MAIN)	EEV	Electronic Expansion Valve
INVERTER PCB	Printed circuit board(INVERTER)	M-BLDC	BLDC Motor
EMI PCB	Printed circuit board(EMI)	OLP-TEMP	Thermistor OLP

NOTE

- This wiring diagram applies only to the outdoor unit.
- Colors blk: black, red: red, blu: blue, wht: white, yel: yellow, brn: brown, sky: skyblue
- When operating, don't short circuit the protection device (High Pressure switch)
- For connection wiring indoor-outdoor transmission F1-F2, outdoor-outdoor transmission OF1-OF2, refer to the installation manual.
- Protective earth(screw), : connector, $\frac{N}{\text{---}}$: The wire quantity

4. Electrical Wiring Diagram

Outdoor Units

CXC30SCB (AC030BXSCCC/AA), CXC36SCB (AC036BXSCCC/AA)

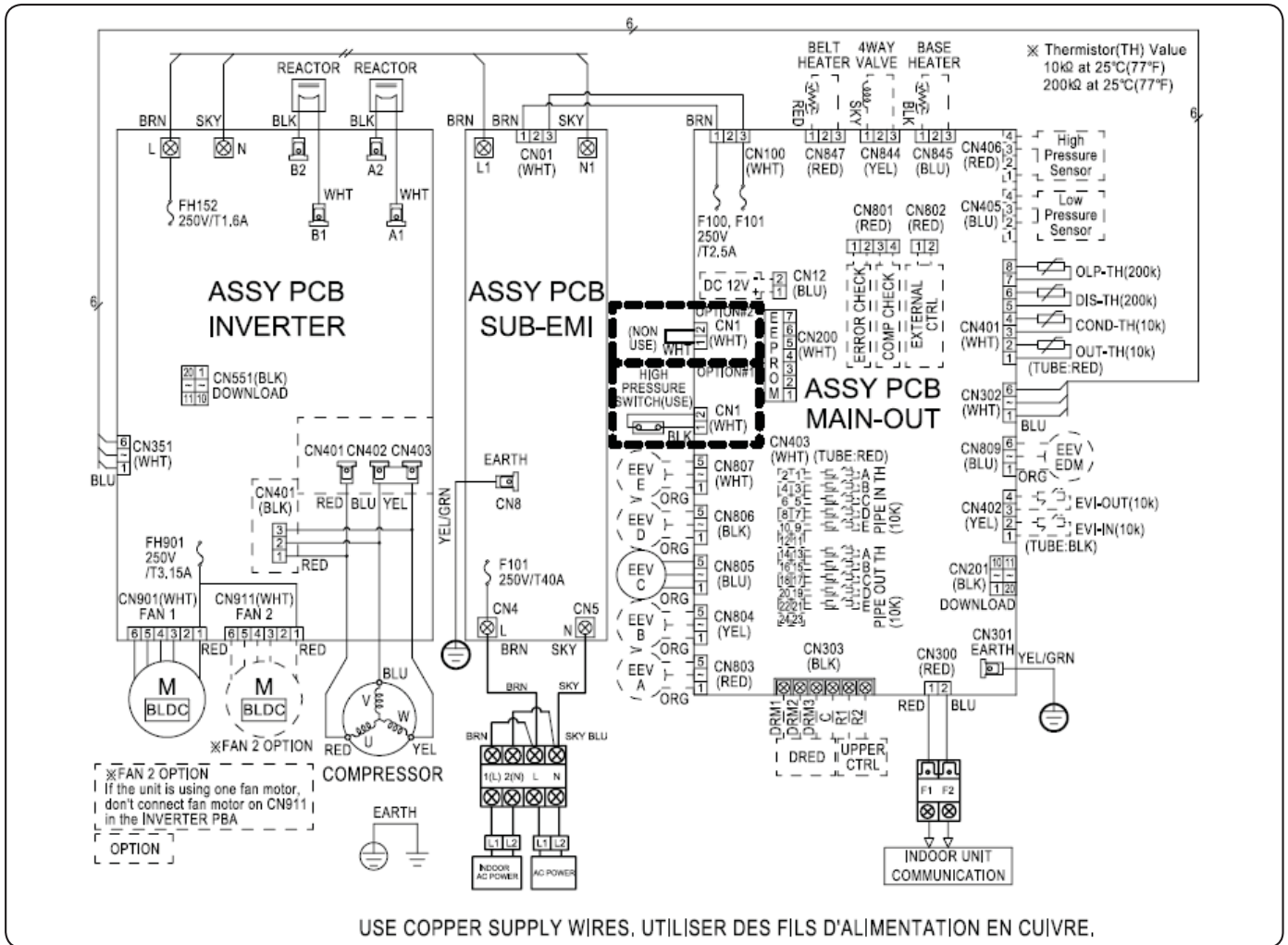

BLDC	Brushless DC Motor	COMP CHECK	Outdoor COMP Operating Check
4WAY	4way Valve	ERROR CHECK	Outdoor Error Check

NOTE

- This wiring diagram applies only to the outdoor unit.
- Colors blk: black, red: red, blu: blue, wht: white, yel: yellow, brn: brown, sky: skyblue
- When operating, don't shortcircuit the protection device (High Pressure switch)
- For connection wiring indoor-outdoor transmission F1-F2, outdoor-outdoor transmission OF1-OF2, refer to the installation manual.
- Protective earth(screw), : connector, : The wire quantity

5. Sound Data

Outdoor Units

Sound Pressure level

Unit: dB(A)

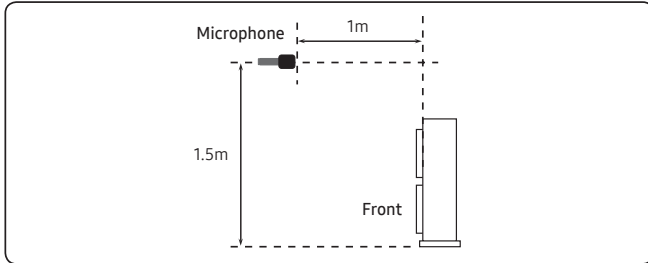

Model	Cooling	Heating
CXC18SCB (AC018BXSCCC/AA)	48	-
CXC24SCB (AC024BXSCCC/AA)	50	-
CXC30SCB (AC030BXSCCC/AA)	52	-
CXC36SCB (AC036BXSCCC/AA)	54	-

- NC Curve

1) CXC18SCB (AC018BXSCCC/AA)

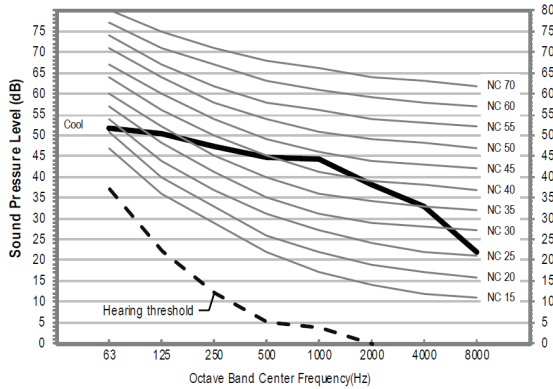

2) CXC24SCB (AC024BXSCCC/AA)

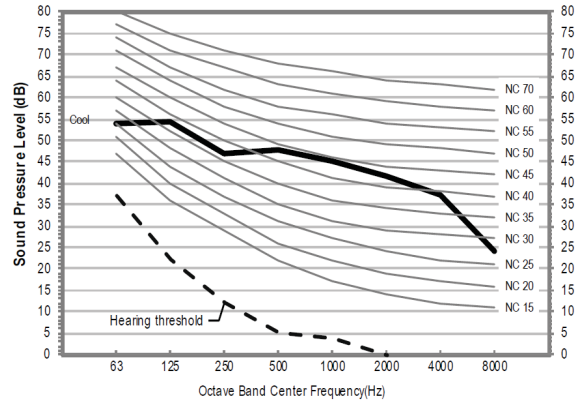

3) CXC30SCB (AC030BXSCCC/AA)

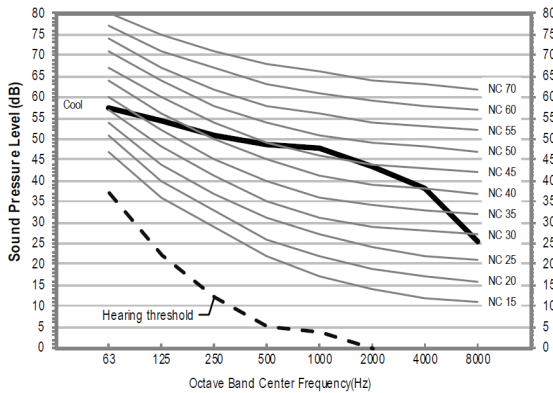

4) CXC36SCB (AC036BXSCCC/AA)

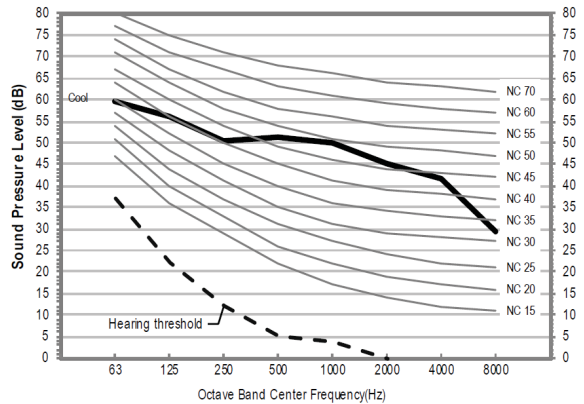

NOTE

- Specifications may be subject to change without prior notice.
 - Sound pressure level is obtained in an anechoic room.
 - Sound pressure level is a relative value, depending on the distance and acoustic environment.
 - Sound pressure level may differ depending on operation condition.
 - dBA = A weighted sound pressure level
 - Reference acoustic pressure 0 dB = 20μPa

5. Sound Data

Outdoor Units

Sound Power level

Unit: dB(A)

NOTE

- Specifications may be subject to change without prior notice
 - Sound power level is an absolute value that a sound source generates.
 - dB(A) = A-weighted sound power level.
 - Reference power : 1pW.
 - Measured according to ISO 3741.

Model	Cooling
CXC18SCB (AC018BXSCCC/AA)	62
CXC24SCB (AC024BXSCCC/AA)	65
CXC30SCB (AC030BXSCCC/AA)	67
CXC36SCB (AC036BXSCCC/AA)	69

• NC Curve

1) CXC18SCB (AC018BXSCCC/AA)

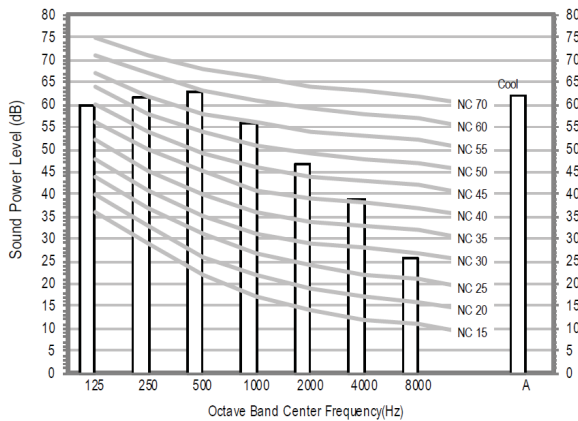

2) CXC24SCB (AC024BXSCCC/AA)

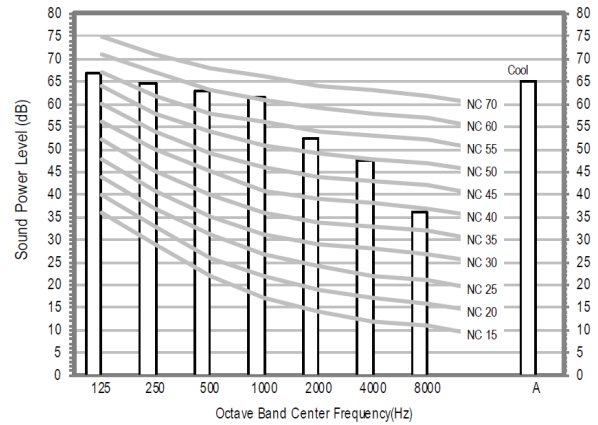

3) CXC30SCB (AC030BXSCCC/AA)

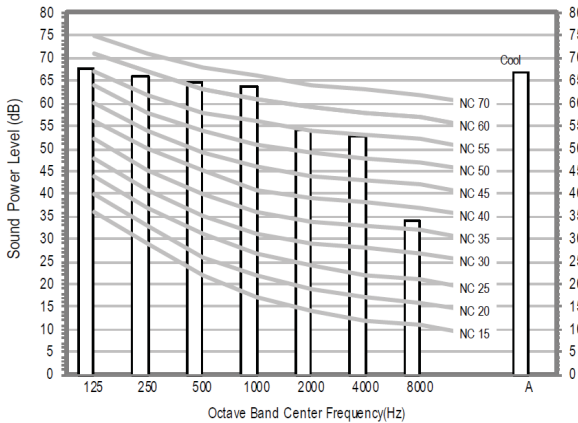

4) CXC36SCB (AC036BXSCCC/AA)

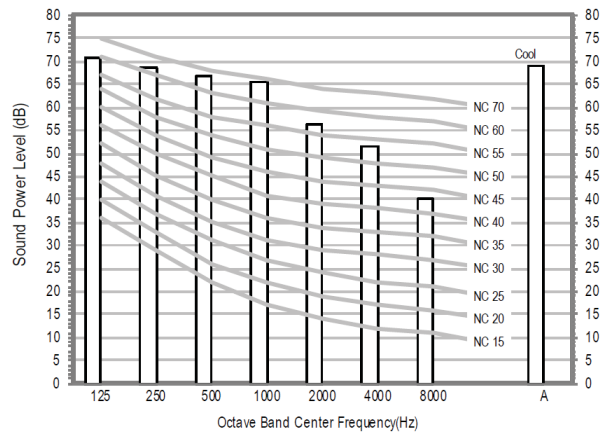

6. Capacity Correction

Outdoor Units

CNH184DB(AC018BN4DCH/AA)+CXC18SCB(AC018BXSCCC/AA)

Cooling



		Pipe Length (ft)					
		24.6	32.8	49.2	65.6	82.0	98.4
Level Difference (ft)	65.6	-	-	-	0.97	0.96	0.95
	49.2	-	-	0.98	0.97	0.96	0.95
	32.8	-	0.99	0.98	0.97	0.96	0.95
	16.4	1.00	0.99	0.98	0.97	0.96	0.95
	0.0	1.00	0.99	0.98	0.97	0.96	0.95
	-16.4	1.00	0.99	0.98	0.97	0.96	0.94
	-32.8	-	0.98	0.97	0.96	0.95	0.93
	-49.2	-	-	0.97	0.96	0.95	0.92
	-65.6	-	-	-	0.96	0.94	0.91

6. Capacity Correction

Outdoor Units

CNH244DB(AC024BN4DCH/AA)+CXC24SCB(AC024BXSCCC/AA)

Cooling



		Pipe Length (ft)									
		24.6	32.8	49.2	65.6	82.0	98.4	114.8	131.2	147.6	164.0
Level Difference (ft)	98.4	-	-	-	-	-	0.94	0.93	0.92	0.91	0.90
	82.0	-	-	-	-	0.96	0.94	0.93	0.92	0.91	0.90
	65.6	-	-	-	0.97	0.96	0.94	0.93	0.92	0.91	0.90
	49.2	-	-	0.98	0.97	0.96	0.94	0.93	0.92	0.91	0.90
	32.8	-	0.99	0.98	0.97	0.96	0.94	0.93	0.92	0.91	0.90
	16.4	1.00	0.99	0.98	0.97	0.96	0.94	0.93	0.92	0.91	0.90
	0.0	1.00	0.99	0.98	0.97	0.96	0.94	0.93	0.92	0.91	0.90
	-16.4	1.00	0.98	0.97	0.96	0.95	0.94	0.93	0.92	0.90	0.88
	-32.8	-	0.98	0.97	0.96	0.95	0.94	0.92	0.91	0.89	0.87
	-49.2	-	-	0.97	0.96	0.94	0.93	0.92	0.90	0.88	0.85
	-65.6	-	-	-	0.96	0.94	0.93	0.91	0.89	0.87	0.83
	-82.0	-	-	-	-	0.94	0.92	0.91	0.89	0.86	0.82
	-98.4	-	-	-	-	-	0.92	0.90	0.88	0.85	0.80

6. Capacity Correction

Outdoor Units

CNH304DB(AC030BN4DCH/AA)+CXC30SCB(AC030BXSCCC/AA)

CNH364DB(AC036BN4DCH/AA)+CXC36SCB(AC036BXSCCC/AA)

Cooling



		Pipe Length (ft)									
		24.6	32.8	49.2	65.6	82.0	98.4	114.8	131.2	147.6	164.0
Level Difference (ft)	98.4	-	-	-	-	-	0.94	0.93	0.92	0.91	0.90
	82.0	-	-	-	-	0.96	0.94	0.93	0.92	0.91	0.90
	65.6	-	-	-	0.97	0.96	0.94	0.93	0.92	0.91	0.90
	49.2	-	-	0.98	0.97	0.96	0.94	0.93	0.92	0.91	0.90
	32.8	-	0.99	0.98	0.97	0.96	0.94	0.93	0.92	0.91	0.90
	16.4	1.00	0.99	0.98	0.97	0.96	0.94	0.93	0.92	0.91	0.90
	0.0	1.00	0.99	0.98	0.97	0.96	0.94	0.93	0.92	0.91	0.90
	-16.4	1.00	0.98	0.97	0.96	0.95	0.94	0.93	0.92	0.90	0.88
	-32.8	-	0.98	0.97	0.96	0.95	0.94	0.92	0.91	0.89	0.87
	-49.2	-	-	0.97	0.96	0.94	0.93	0.92	0.90	0.88	0.85
	-65.6	-	-	-	0.95	0.94	0.93	0.91	0.89	0.87	0.83
	-82.0	-	-	-	-	0.94	0.92	0.91	0.89	0.86	0.82
-98.4	-	-	-	-	-	0.92	0.90	0.88	0.85	0.80	

7. Operation Range

Outdoor Units

Mode	Indoor temperature	Outdoor temperature	Indoor humidity
Cooling	18°C to 32°C (64°F to 90°F)	-40°C to 50°C (-40°F to 122°F)	80% or less
Drying	18°C to 32°C (64°F to 90°F)	-40°C to 50°C (-40°F to 122°F)	80% or less

 **NOTE**

- The assumed installation conditions are follows
 - The pipe length(including elbow) is 7.5m(24.6ft).
 - The level difference is 0 m.

8. Piping Diagram

Outdoor Units

CNH184DB (AC018BN4DCH/AA) + CXC18SCB (AC018BXSCC/AA)

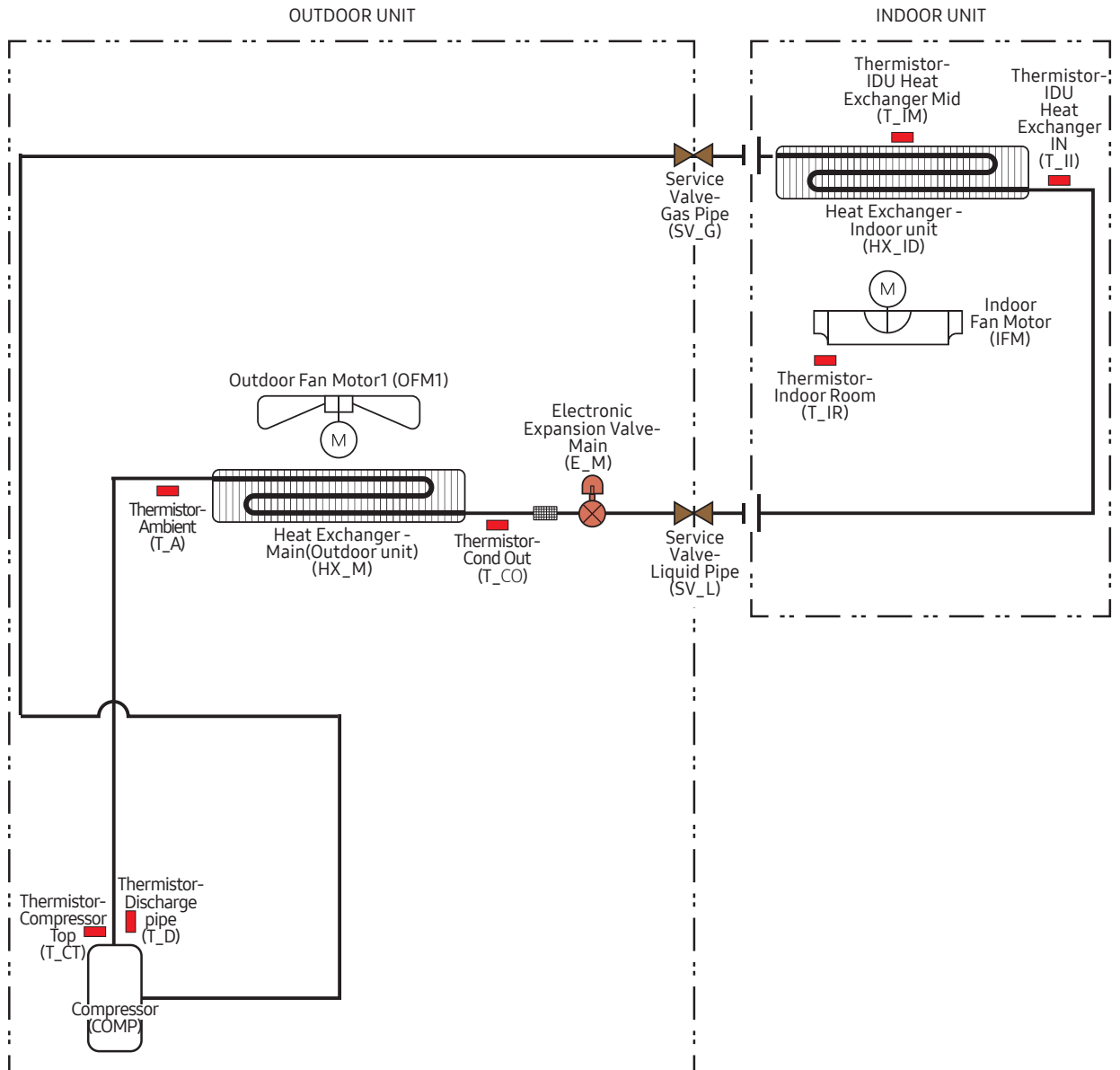

8. Piping Diagram

Outdoor Units

CNH244DB (AC024BN4DCH/AA) + CXC24SCB (AC024BXSCCC/AA)
CNH304DB (AC030BN4DCH/AA) + CXC30SCB (AC030BXSCCC/AA)
CNH364DB (AC036BN4DCH/AA) + CXC36SCB (AC036BXSCCC/AA)

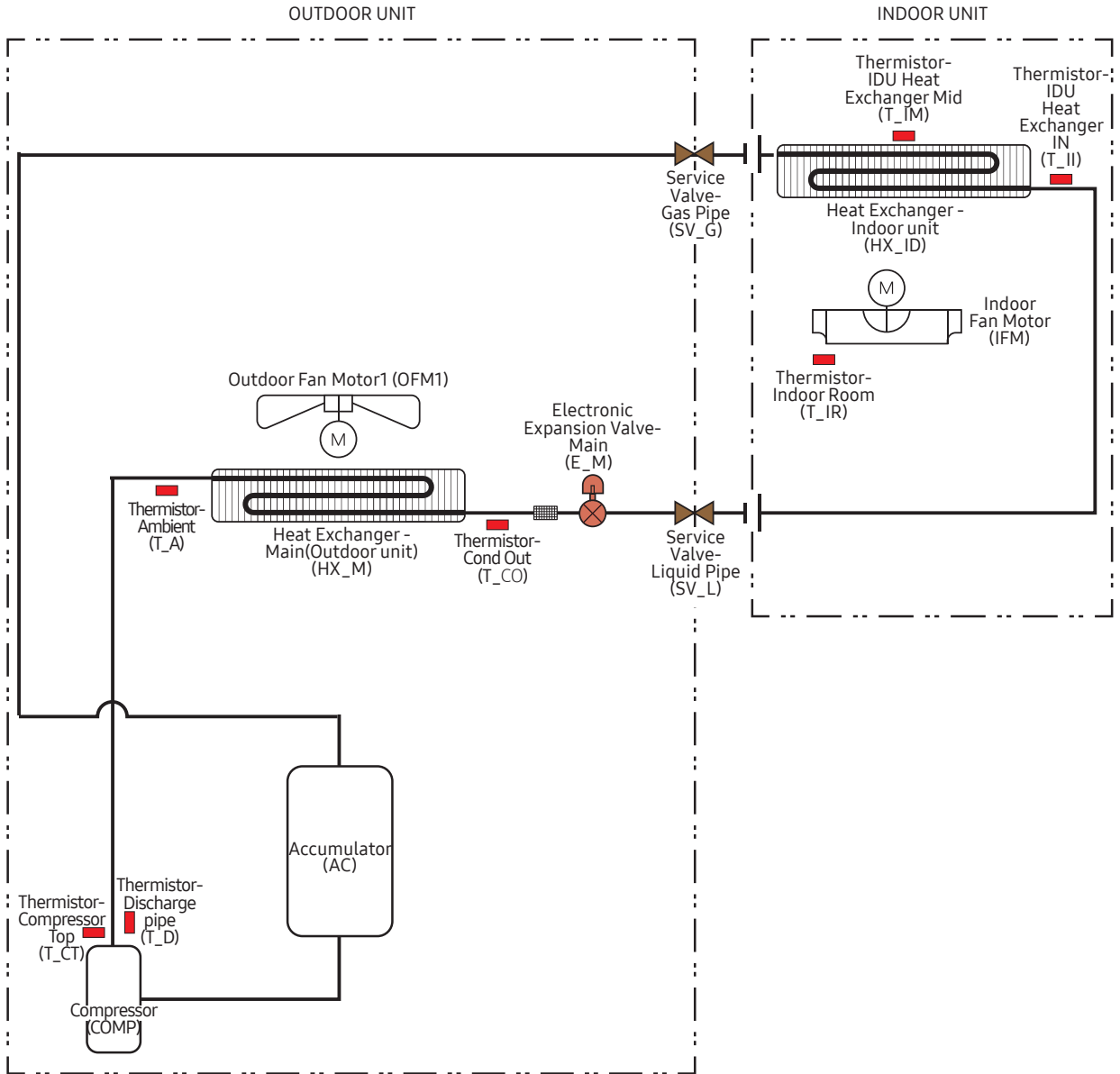

Installation

4 Way Cassette

Choosing the installation location

Installation location requirements

- There must be no obstacles near the air inlet and outlet.
- Install the indoor unit on a ceiling that can support its weight.
- Maintain sufficient clearance around the indoor unit.
- Before installing the indoor unit, be sure to check whether the chosen location is well-drained.
- The indoor unit must be installed such that it is beyond public access and is not touchable by users.
- A vibration-resistant location that is not inclined (If the indoor unit is installed on a structure that is not sturdy, it may fall and get damaged or cause injury.)
- Where it is not exposed to direct sunshine.
- Where the air filter can be removed and cleaned easily.

⚠ CAUTION

- As a rule, the unit cannot be installed at a height of less than 8.2ft (2.5m).
- If you install a cassette type indoor unit on the ceiling when temperature is over 80.6°F (27°C) and humidity is over 80%, you must apply an extra 0.39inch (10mm) thick polyethylene insulation or a similar type of insulation to the body of the indoor unit.

Do not install the air conditioner in following places.

- A place with exposure to mineral oil, oil vapour or cooking area where there is spray (If oil adheres to the heat exchanger, performance degradation, spray or condensation scattering may occur. If oil adheres to a plastic component, the component may deform or get damaged. Such issues may result in a system failure or refrigerant leak.)
- The place where corrosive gas such as sulphuric acid gas generates from the vent pipe or air outlet.
- The copper pipe or connection pipe may corrode and refrigerant may leak.
- The place where there is a machine that generates electromagnetic waves. The air conditioner may not operate normally due to control system.
- The place where there is a danger of existing combustible gas, carbon fibre or flammable dust.
- The place where thinner or gasoline is handled. Gas may leak and it may cause fire.

Spacing requirements

4 way Cassette

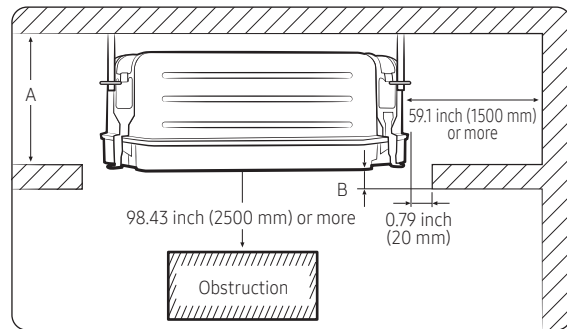

Unit: inch(mm)

	AC018BN4DCH AC024BN4DCH	AC030BN4DCH AC036BN4DCH
A	11.54 (293)	13.19 (335)
B	0.67 (17)	0.67 (17)

Installation

4 Way Cassette

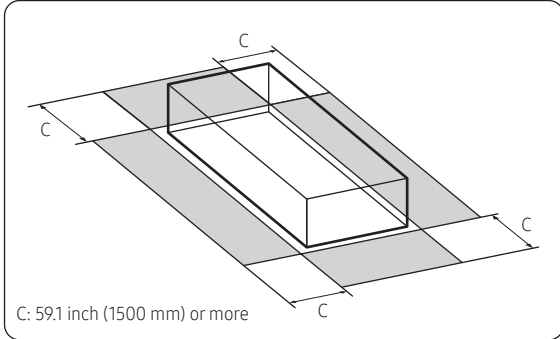

⚠ CAUTION

- The indoor unit must be installed according to the specified distances in order to permit accessibility from each side, to guarantee correct operation, maintenance, and repair of the unit.
The components of the indoor unit must be reachable and removable under safe conditions for people and the unit.
- Do not carry the unit by holding the refrigerant or drain pipes to avoid product damage.
- Carry the unit by holding the hanger plates located on the corners of the unit.

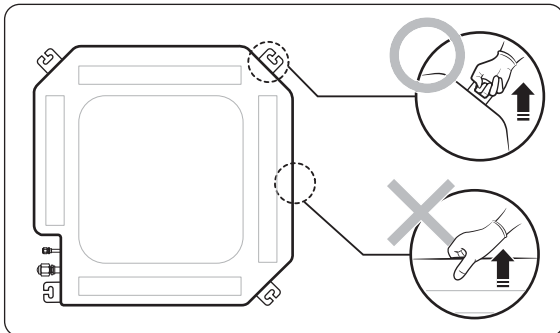

Optional: Insulating the body of the indoor unit

If you install a cassette type indoor unit on the ceiling when temperature is over 80.6 °F (27 °C) and humidity is over 80%, you must apply an extra 10 mm thick polyethylene insulation or a similar type of insulation to the body of the indoor unit.

Cut away the part where pipes are pulled out for the insulating work.

4 way Cassette

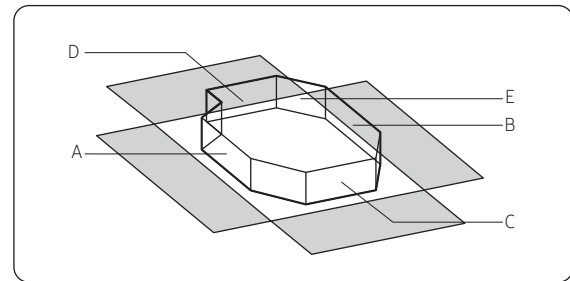

Insulate the end of the pipe and some curved area by using separate insulator.

📄 NOTE

- A: Reference for the outer circumference of the unit (When insulating the body of the indoor unit, use A as the reference for its outer circumference.)

4 way Cassette

Indoor unit		A	B	C	D	E
4 way Cassette	AC018BN4DCH	35.83X7.60	37.00X7.60	24.02X7.60	25.59X7.60	34.25X34.25
	AC024BN4DCH	(910X193)	(940X193)	(610X193)	(650X193)	(870X870)
	AC030BN4DCH	35.83X9.25	37.00X9.25	24.02X9.25	25.59X9.25	34.25X34.25
	AC036BN4DCH	(910X235)	(940X235)	(610X235)	(650X235)	(870X870)

Installation

4 Way Cassette

Installing the indoor unit

When deciding on the location of the air conditioner the following restrictions must be taken into account.

- 1 Place the pattern sheet on the ceiling at the location where you want to install the indoor unit.

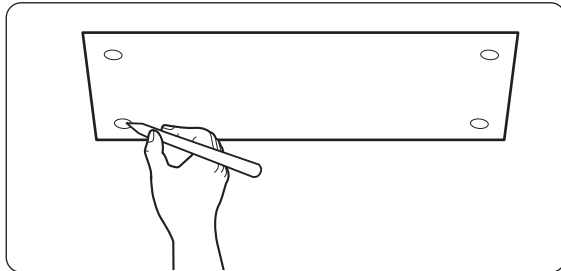

NOTE

- Since the diagram is made of paper, it may shrink or stretch slightly due to temperature or humidity. For this reason, before drilling the holes, be sure to maintain the correct dimensions between the markings.

- 2 Insert bolt anchors, use existing ceiling supports or construct a suitable support as shown in figure.

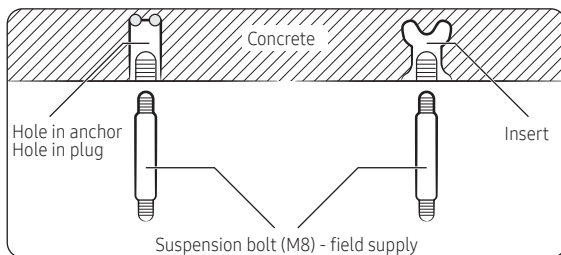

- 3 Install the suspension bolts, depending on the ceiling type.

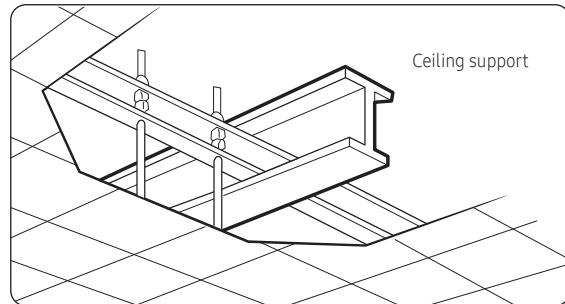

CAUTION

- Make sure that the ceiling is strong enough to support the weight of the indoor unit. Before hanging the unit, test the strength of each attached suspension bolt.
 - If the length of the suspension bolt is more than 4.92ft(1.5m), vibration prevention is recommended. If this is not possible, create an opening on the false ceiling in order to be able to use it to perform the required operations on the indoor unit.
- 4 Screw eight nuts and washers to the suspension bolts, making space for hanging the indoor unit.

CAUTION

- You must install all of the suspension rods.
- It is important to leave sufficient space in the false ceiling to allow access for maintenance or repairs to the drainage pipe connection, the refrigerant pipe connection, or to remove the unit if necessary.

- 5 Hang the indoor unit to the suspension bolts between two nuts. Screw the nuts to suspend the unit.

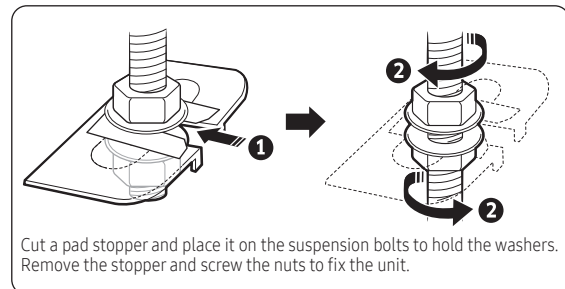

- 6 Check the level of the indoor unit by using a Level.
 - A tilt of the indoor unit may cause malfunction of a built-in float switch and water leaks.

Installation

4 Way Cassette

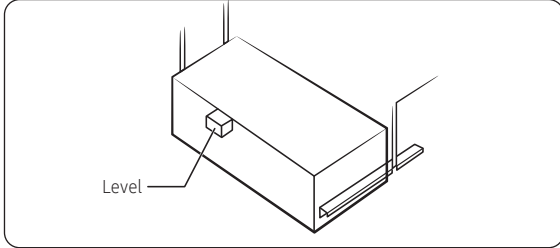

- 7 Adjust the unit to the appropriate position, taking into account the installation area for the front panel.
- Place the pattern sheet on the indoor unit.
 - Adjust the space between the ceiling and the indoor unit by using a Tape measure.
 - Fix the indoor unit securely after adjusting the level of the unit by using a level.
 - Remove the pattern sheet and install the front panel.

When the installation template is made of paper

4 way Cassette

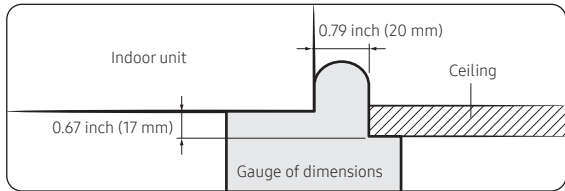

Installing the drain hose and drain pipe

- 1 Push the supplied drain hose as far as possible over the drain socket.
- 2 Tighten the metal clamp as shown in the picture.

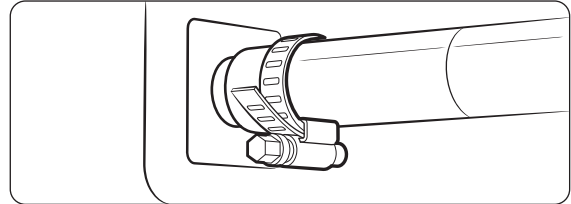

- 3 Wrap the supplied large sealing pad over the metal clamp and drain hose to insulate and fix it with clamps.
- 4 Insulate the complete drain piping inside the building (field supply).
If the drain hose cannot be sufficiently set on a slope, fit the hose with drain raising piping (field supply).
- 5 Push the drain hose up to insulation when connecting the drain hose to drain socket.

4 way Cassette

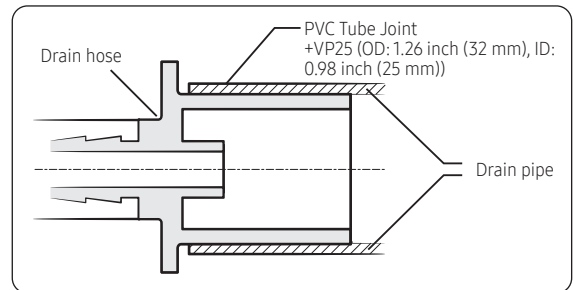
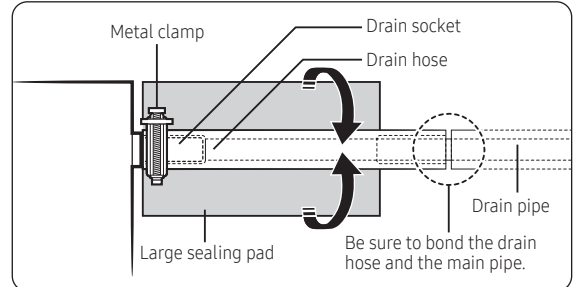

Installation

4 Way Cassette

⚠ CAUTION

Check that the indoor unit is level with the ceiling by using a level.

- Install air ventilation to drain condensation smoothly.

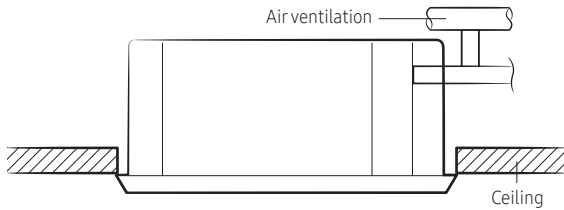

- If it is necessary to increase the height of the drain pipe, install the drain pipe straight within 11.81 inch (300 mm) from the drain hose port. If it is raised higher than 21.65 inch (550 mm), there may be water leaks.

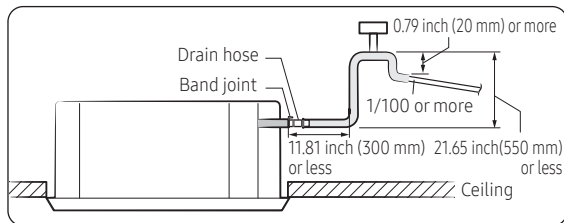

- Do not give the hose an upward gradient beyond the connection port. This will cause water to flow backwards when the unit is stopped, resulting in water leaks.

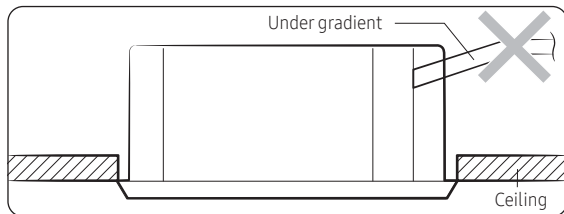

- Do not apply force to the piping on the unit side when connecting the drain hose. The hose should not be allowed to hang loose from its connection to the unit. Fasten the hose to a wall, frame or other support as close to the unit as possible.

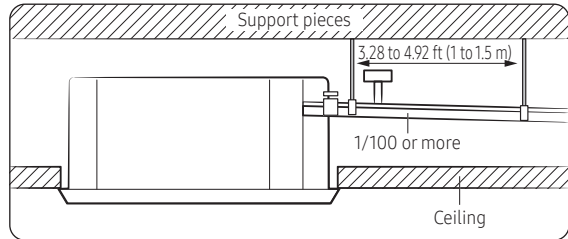

- Install horizontally.

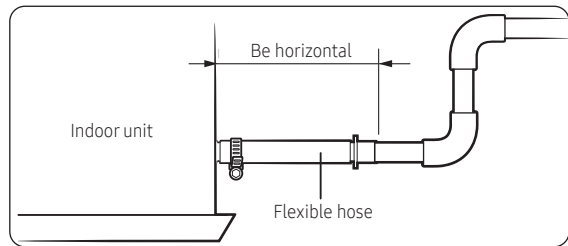

- Max. allowable aaxis gap

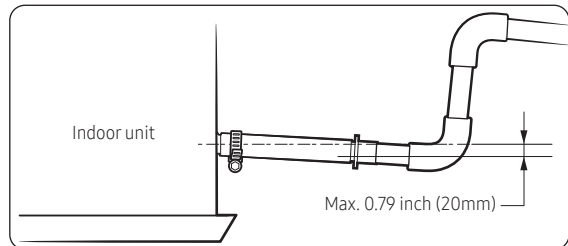

- Max. allowable bending angle

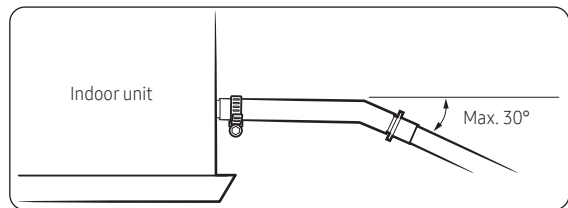

📄 NOTE

- If a concentrated drain pipe is installed, refer to the figure below.

Installation

4 Way Cassette

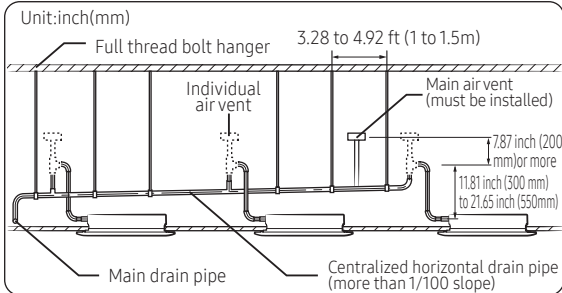

- If 3 or more units are installed, install a main air vent in front of the farthest indoor unit from the main drain pipe.
- To prevent water from flowing back to indoor units, install an individual air vent at the top of each indoor unit.
 - The air vents should be T or 7 shaped to prevent dust or foreign substances from entering.
 - You may not need to install an air vent if the horizontal drain pipe has a proper slope.

Connecting the power and communication cables

Bushing bracket installation

When connecting the power supply wire conduit, the supplied bracket must be installed as shown in the picture below.

4 way Cassette

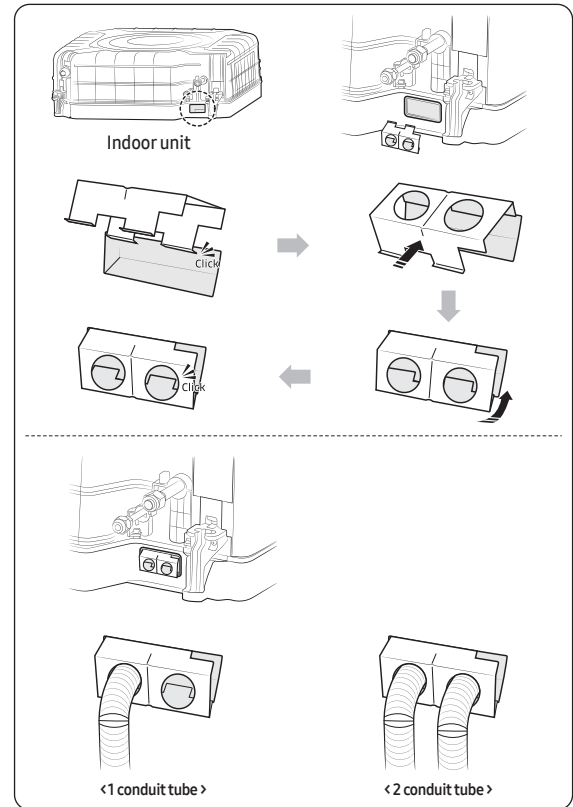

Installation

4 Way Cassette

NOTE

- Please follow national and local electrical codes. Additional electrical connection components may be required.

CAUTION

- Always remember to connect the refrigerant pipes before performing the electric connections. When disconnecting the system, always disconnect the electric cables before disconnecting the refrigerant pipes.
- Always remember to connect the air conditioner to the grounding system before performing the electric connections. Use a crimp ring terminal at the end of each wire.

The indoor unit is powered through the outdoor unit by means of a H05 RN-F connection cable (or a more power model), with insulation in synthetic rubber and a jacket in polychloroprene (neoprene), in accordance with the requirements specified in the standard EN 60335-2-40.

- 1 Remove the screw on the electrical component box and remove the cover plate.
- 2 Route the connection cord through the side of the indoor unit and connect the cable to the terminals refer to the figure below.

- 3 Route the other end of the cable to the outdoor unit through the ceiling & the hole on the wall.
- 4 Reassemble the electrical component box cover, carefully tightening the screw.

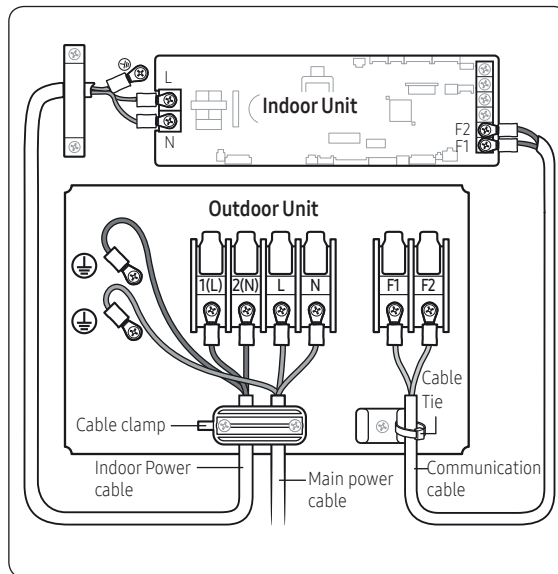

Installation

4 Way Cassette

Indoor power supply		
Power supply	Max/Min(V)	Indoor power cable
208 to 230V, 60 Hz	±10%	0.0012 inch ² ↑ (0.75mm ² ↑), 3 wires
Communication cable		
0.0012 inch ² ↑(0.75mm ² ↑), 2 wires		

Unit: inch(mm)

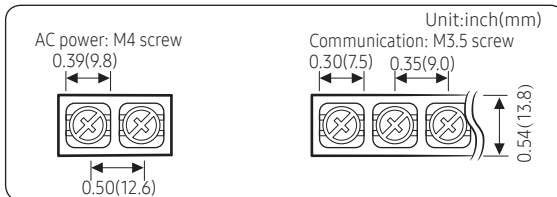

Tightening torque lbf-ft (kgf • cm)	
M3.5	0.58 to 0.87 (8.0 to 12.0)
M4	0.87 to 1.30 (12.0 to 18.0)

- Power supply cords of parts of appliances for outdoor use shall not be lighter than polychloroprene sheathed flexible cord. (Code designation IEC:60245 IEC 57 / CENELEC: H05RN-F)
- Since it has the external power supply, refer to the outdoor unit installation manual for MAIN POWER.

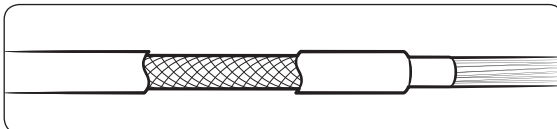

⚠ CAUTION

- When installing the indoor unit in a computer room or network room, use the double shielded communication cable (tape aluminum / polyester braid + copper) of FROHH2R type.
- Select the power cable in accordance with relevant local and national.
- Wire size must comply with local and national code.
- You should connect the power cable into the power cable terminal and fasten it with a clamp.
- The unbalanced power must be maintained within 10% of supply rating among whole indoor units.
- If the power is unbalanced greatly, it may shorten the life of the condenser. If the unbalanced power is exceeded by more than 10% of supply rating, the indoor unit will protect itself by stopping and displaying an error code.
- Connect the power cable to the auxiliary circuit breaker. An all pole disconnection from the power supply must be incorporated in the fixed wiring (≥0.12inch (3mm)).

- You must keep the cable in a protection tube.
- Maximum length of power cables are decided within 10% of power drop. If it exceeds, you must consider another power supplying method.
- The circuit breaker (MCCB, ELB) should be considered more capacity if many indoor units are connected from one breaker.
- Use round pressure terminal for connections to the power terminal block.
- For wiring, use the designated power cable and connect it firmly, then secure to prevent outside pressure being exerted on the terminal board.
- Use an appropriate screwdriver for tightening the terminal screws. A screwdriver with a small head will strip the head and make proper tightening impossible.
- Over-tightening the terminal screws may break them.

Installation

Duct

Spacing requirements

Space requirements for installation & service.

Construction Standard for Inspection opening

An inspection opening is required for service and unit replacement.

- 1) If the ceiling is a grid type, an inspection opening is not required.
- 2) If the ceiling is plaster board, an inspection opening is required. The size of the opening will vary based on the height inside the ceiling.
 - a. Height is more than 1.64ft (0.5m): Only "B" [Inspection for PBA] is applied.
 - b. Height is less than 1.64ft (0.5m): Both "A"&"B" are applied.
 - c. "A"&"B" are inspection opening .

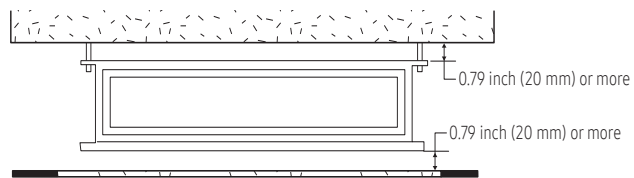
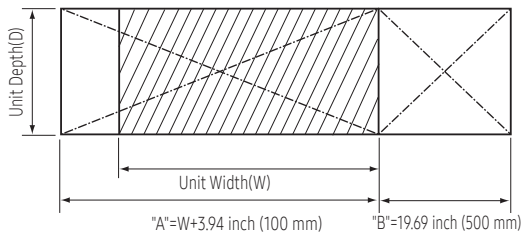

- You must have 0.79 inch (20 mm) or more space between the ceiling and the bottom of indoor unit to prevent transmission of noise and vibration from the unit into the space.
- It is possible to install the unit at an height of between 7.2~8.2 ft (2.2~2.5 m) from the ground, if the unit has a duct with a well defined length [11.81inch (300 mm) or more], to avoid fan motor blower contact.
- If you install the cassette or duct type indoor unit on the ceiling with humidity over 80%, you must apply extra 0.39 inch (10mm) of polyethylene foam or other insulation with similar material on the body of the indoor unit.

Optional: Insulating the body of the indoor unit

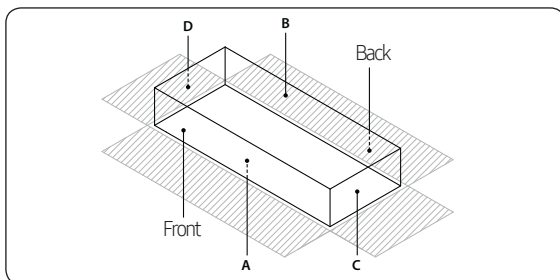

Thickness: more than 0.39 inch(10mm)

Unit: inch(mm)

Indoor Unit	AC018BNHDCH AC024BNHDCH AC030BNHDCH	AC036BNHDCH
		47.24X27.56X9.84 (1200X700X250)
A	47.24X27.5 (1200X700)	51.18X27.56 (1300X700)
B	47.24X27.5 (1200X700)	51.18X27.56 (1300X700)
C	27.56X9.84 (700X250)	27.56X11.81 (700X300)
D	27.56X9.84 (700X250)	27.56X11.81 (700X300)
Front/ Back	Insulate the front and back side in proper size at the same time when insulating the suction duct and discharge duct.	

NOTE

- Insulate the end of the pipe and some curved area by using separate insulator.
- Insulate the discharge and suction part at the same time when you insulate connection duct.

Installation

Duct

Installing the indoor unit

When deciding on the location of the air conditioner with the owner, the following restrictions must be taken into account

- 1 Place the pattern sheet on the ceiling at the spot where you want to install the indoor unit.

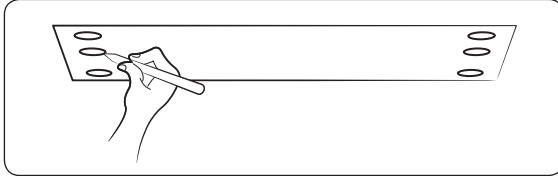

NOTE

- Since the diagram is made of paper, it may shrink or stretch slightly due to temperature or humidity. For this reason, before drilling the holes maintain the correct dimensions between the markings.
- 2 Insert bolt anchors. Use existing ceiling supports or construct a suitable support as shown in figure.

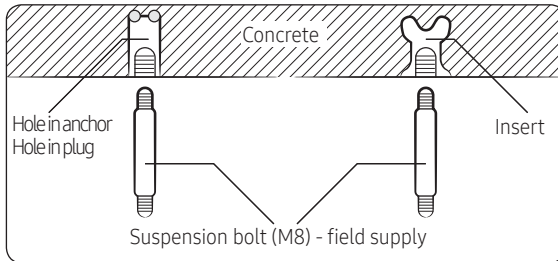

- 3 Install the suspension bolts depending on the ceiling type.

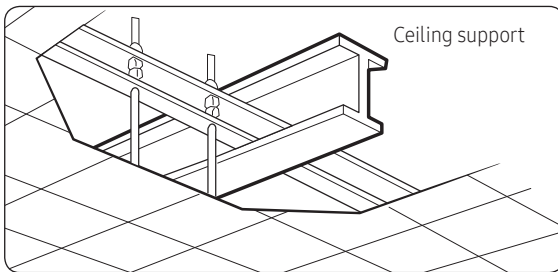

CAUTION

- Ensure that the ceiling is strong enough to support the weight of the indoor unit. Before hanging the unit, test the strength of each attached suspension bolt.
- If the length of suspension bolt is more than 4.92 ft (1.5m), it is required to prevent vibration.
- If this is not possible, create an opening on the false ceiling in order to be able to use it to perform the required operations on the indoor unit.

- 4 Screw eight nuts to the suspension bolts making space for hanging the indoor unit.

NOTE

- You must install all the suspension rods.
- 5 Hang the indoor unit to the suspension bolts between two nuts.

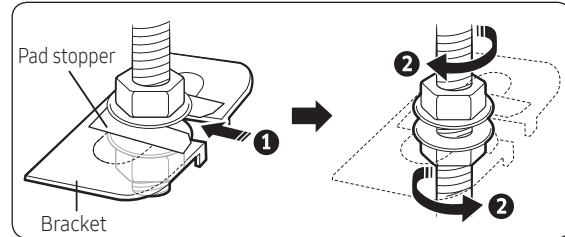

CAUTION

- Piping must be laid and connected inside the ceiling when suspending the unit. If the ceiling is already constructed, lay the piping into position for connection to the unit before placing the unit inside the ceiling.
- 6 Screw the nuts to suspend the unit.
- 7 Adjust level of the unit by using measurement plate for all 4 sides.

CAUTION

- For proper drainage of condensate, give a 0.118 inch (3mm) slant to the left or right side of the unit which will be connected with the drain hose, as shown in the figure. Make a tilt when you wish to install the drain pump, too.

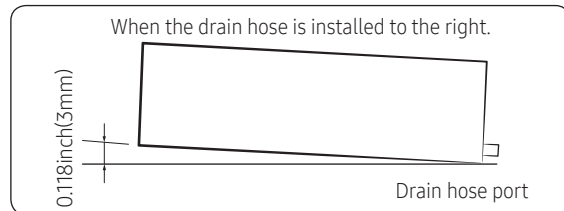

- When installing the indoor unit, make sure it is not tilted toward front or back side.

CAUTION

- Noise will increase 3~6 dB(A) when the air flow enters from the bottom side (Only for AC***BNLDCH indoor unit product).

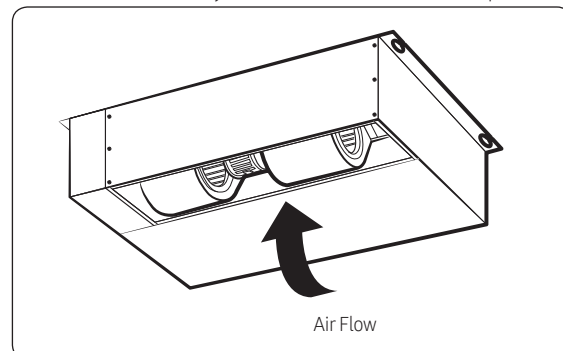

Installation

Duct

Installing the drain hose and drain pipe

- 1 Push the supplied drain hose as far as possible over the drain socket.
- 2 Tighten the metal clamp as shown in the picture.

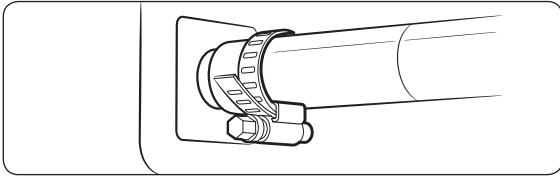

- 3 Wrap the supplied large sealing pad over the metal clamp and drain hose to insulate and fix it with clamps.
- 4 Insulate the complete drain piping inside the building (field supply). If the drain hose cannot be sufficiently set on a slope, fit the hose with drain raising piping (field supply).
- 5 Push the drain hose up to insulation when connecting the drain hose to drain socket.

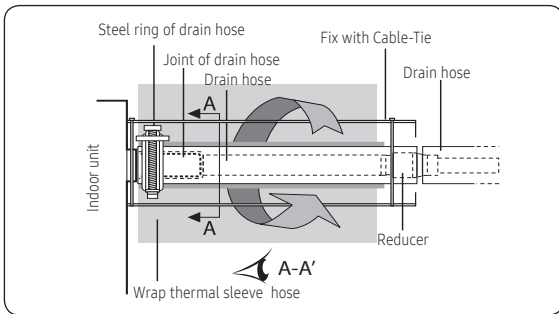

Without the drain pump

- 1 Install horizontal drainpipe with a slope of 1/100 or more and fix it by hanger space of 3.28~4.92ft(1~1.5m).
- 2 Install U-trap at the end of the drainpipe to prevent a nasty smell to reach the indoor unit.
- 3 Do not install the drainpipe to upward position. It may cause water flow back to the unit.

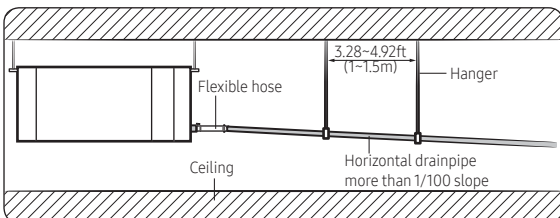

With the drain pump

- 1 The drain pipe should be installed within 11.81inch(300mm) to 21.65inch(550mm) from the flexible hose and then lift down 0.79inch(20mm) or more.
- 2 Install horizontal drainpipe with a slope of 1/100 or more and fix it by hanger space of 3.28~4.92ft(1~1.5m).
- 3 Install the air vent in the horizontal drainpipe to prevent water flow back to the indoor unit.

NOTE

- You may not need to install it if there were proper slope in the horizontal drainpipe.
- 4 The flexible hose should not be installed upward position, it may cause water flow back to the indoor unit.

Centralized drainage without the drain pump

- 1 Install horizontal drainpipe with a slope of 1/100 or more and fix it by hanger space of 3.28~4.92ft(1~1.5m).
- 2 Install U-trap at the end of the drainpipe to prevent a nasty smell to reach the indoor unit.

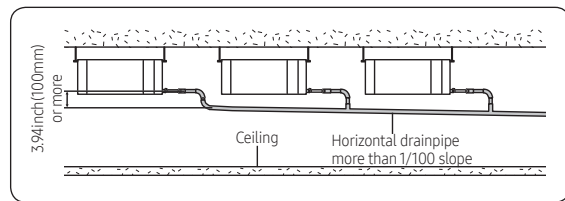

Centralized drainage with the drain pump

- 1 Install main air vent at the front of the farthest indoor unit from the main drain when installed indoor units are more than 3.
- 2 You may need to install individual air vent to prevent water flow back at the top of each indoor unit drainpipe.

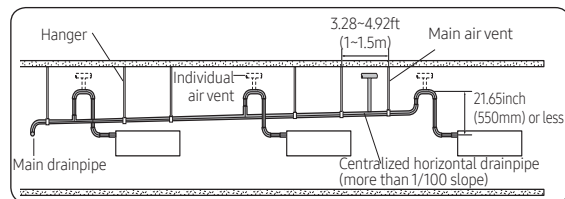

Installation

Duct

Connecting the power and communication cables

⚠ CAUTION

- Always remember to connect the refrigerant pipes before performing the electric connections. When disconnecting the system, always disconnect the electric cables before disconnecting the refrigerant pipes.

⚠ CAUTION

- Always remember to connect the air conditioner to the grounding system before performing the electric connections. Use a crimp ring terminal at the end of each wire.

The indoor unit is powered through the outdoor unit by means of a H05 RN-F connection cable (or a more power model), with insulation in synthetic rubber and a jacket in polychloroprene (neoprene), in accordance with the requirements specified in the standard EN 60335-2-40.

- Remove the screw on the electrical component box and remove the cover plate.
- Route the connection cord through the side of the indoor unit and connect the cable to the terminals refer to the figure below.
- Route the other end of the cable to the outdoor unit through the ceiling & the hole on the wall.
- Reassemble the electrical component box cover, carefully tightening the screw.

AC***BNHDCH

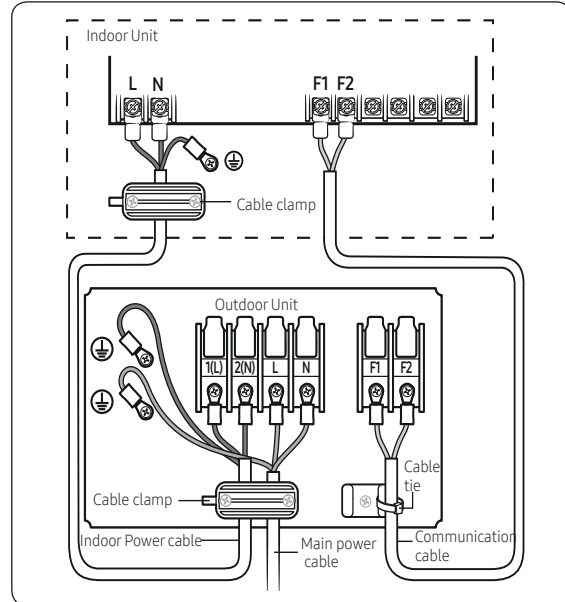

📄 NOTE

- Terminal Block of the outdoor unit may be different from the diagram depending on the model. Refer to the manual of the outdoor unit for the configuration of the terminal block of the outdoor unit.

Indoor power supply		
Power supply	Max/Min(V)	Indoor power cable
208 to 230V, 60 Hz	±10%	0.0023 inch ² ↑ (1.5mm ² ↑), 3 wires
Communication cable		
0.0012 inch ² ↑ (0.75mm ² ↑), 2 wires		

Installation

Duct

AC***BNHDCH

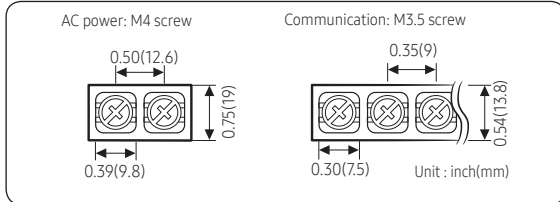

Tightening torque lbf·ft (kgf·cm)	
M3.5	0.58 to 0.87 (8.0 to 12.0)
M4	0.87 to 1.30 (12.0 to 18.0)

- Power supply cords of parts of appliances for outdoor use shall not be lighter than polychloroprene sheathed flexible cord.
-Code designation
[1-phase] IEC: 60245 IEC 57 / CENELEC: H05RN-F grade or more
- Be sure to run the power supply cable and the communication cable through electrical conduit as seen in the picture.

AC***BNHDCH

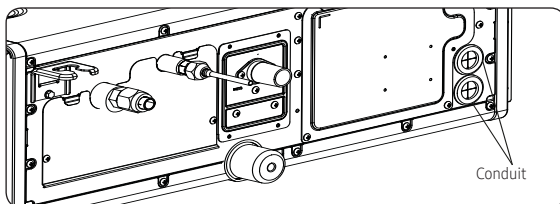

⚠ CAUTION

- Be sure not to put your finger into the conduit.
- Since it has the external power supply, refer to the outdoor unit installation manual for MAIN POWER.

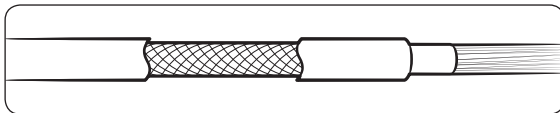

⚠ CAUTION

- When installing the indoor unit in a computer room or a server room, use the double shielded communication cable (tape aluminum / polyester braid + copper) of FROHH2R type.

Installation

Wall Mounted Type CNH18/24ADB(AC018/024BNADCH/AA)

Choosing the installation location

Installation location requirements

- There must be no obstacles near the air inlet and outlet.
- Install the indoor unit on a ceiling that can support its weight.
- Maintain sufficient clearance around the indoor unit.
- Before installing the indoor unit, be sure to check whether the chosen location is well-drained.

⚠ WARNING

- **IMPORTANT:** it's mandatory to consider either the table 1 or taking into consideration the local law regarding the minimum living space of the premises.
- Minimum installation height of indoor unit is 0.6 m for floor mounted, 1.8 m for wall, 2.2 m for ceiling.

⚠ CAUTION

Do not install the air conditioner in following places.

- The place where there is mineral oil or arsenic acid. Resin parts flame and the accessories may drop or water may leak. The capacity of the heat exchanger may reduce or the air conditioner may be out of order.
- The place where corrosive gas such as sulfurous acid gas generates from the vent pipe or air outlet. The copper pipe or connection pipe may corrode and refrigerant may leak.
- The place where there is a machine that generates electromagnetic waves. The air conditioner may not operate normally due to control system.
- The place where there is a danger of existing combustible gas, carbon fiber or flammable dust.
- The place where thinner or gasoline is handled. Gas may leak and it may cause fire.
- The place where animals may urinate on the product. Ammonia may be generated.
- The place where is close to heat sources.

Overview of installation location requirements

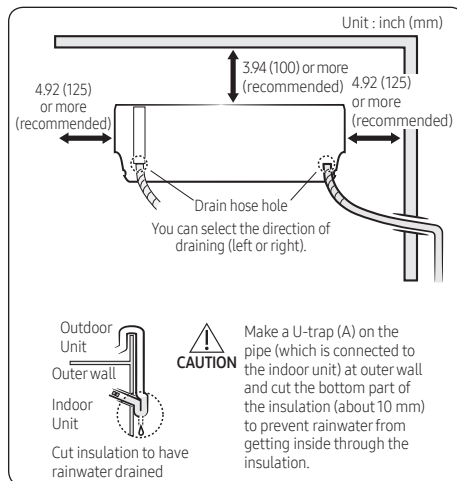

NOTE

- The appearance of the unit may be different from the diagram depending on the model.

Attaching the mounting bracket to the wall

- 1 Hold the mounting bracket against the wall at the selected installation position (in Step 2), making sure that the screw holes align with the center of the studs in the wall. If the screw locations do not align with the studs, use wall anchors.

⚠ CAUTION

- The recommended best practice is to attach the mounting bracket directly to the studs in the wall. If you did not find a suitable location with studs (in Step 2), or if the wall is concrete, you must use wall anchors of a suitable type and weight capacity, and install them according to the manufacturer's instructions. Failure to do so may cause the material surrounding the joints to crumble over time and the screws to be loosened and stripped. This may result in the unit falling from the wall, which could cause physical injury or equipment damage.
- 2 Using a level, make sure that the mounting bracket is level, then mark the location of the screw holes on the wall.
 - 3 If using wall anchors, install them at the screw hole positions, following the manufacturer's instructions.
 - 4 Using six field-supplied mounting screws and anchors (if applicable), attach the bracket to the wall.

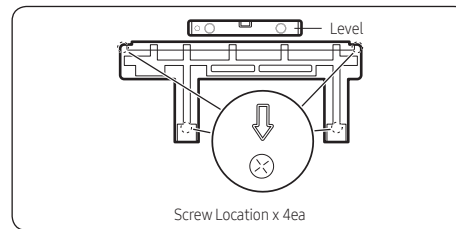

Drilling the wall penetration

- 1 Determine the position of the hole through which the piping bundle (consisting of power and communication cables, refrigerant pipes, and the drain hose) will pass. Consider the following:
 - The hole inner diameter must be 2.56 inch (65mm).
 - The recommended hole location is behind the unit so that the hole and the piping bundle will not be visible in the room. The minimum distances between the hole and the mounting bracket are:

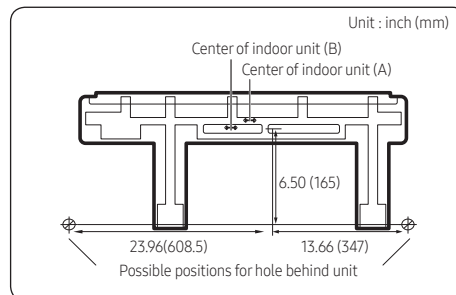

Installation

Wall Mounted Type CNH18/24ADB(AC018/024BNADCH/AA)

- If the hole cannot be positioned behind the unit, find a position as close to the unit as possible. The piping bundle that exits the unit and extends to the hole will need to be attached to the wall and will be visible inside the room.
- In relation to the bracket shown above, the unit is shipped with the drain hose connection on the right, the drain hose exits the unit on the left, and the refrigerant pipes are bent to exit on the left. Thus, positioning the hole to the left requires the least effort. If you position the hole to the right or below the unit, you will need to move the drain hose connection to the left and bend the pipes so that the hose and pipes exit to the right or bottom. See the figure in Step 7.

- 2 Use a standard 2.56 inch(65mm) hole saw to drill one hole at the selected location, at a 15° downward angle so that the drain hose will drain properly.

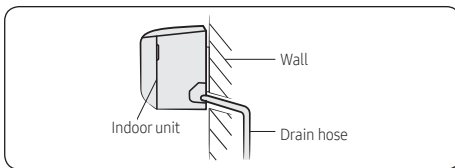

- 3 Based on the hole location, determine where the piping bundle (drain hose, refrigerant pipes, and cables) will exit the unit.

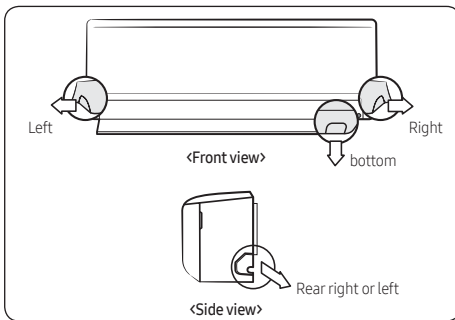

NOTE

- The left, right, or bottom exit will only be used if the hole is not positioned behind the unit.

Connecting the refrigerant pipes

Connect indoor and outdoor units with field-supplied copper pipes by means of flare connections. Use insulated seamless refrigeration grade pipe only, (Cu DHP type according to ISO1337), degreased and deoxidized, suitable for operating pressures of at least 4200 kPa and for burst pressure of at least 20700 kPa. Under no circumstances must sanitary type copper pipe be used.

IMPORTANT

- When installing the unit, always connect the refrigerant pipes first, followed by the electrical cables. For disassembly, always disassemble the electric cables before the refrigerant pipes.

Two short refrigerant pipes are already attached to the air conditioner:

- The smaller-diameter pipe is for the high-pressure, two-phase refrigerant.
- The larger-diameter pipe is for the low-pressure refrigerant vapor.

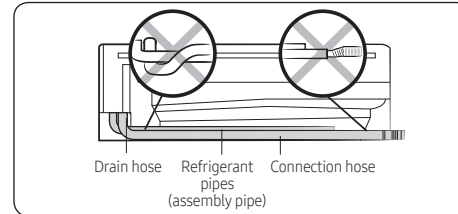

In Step 4 you determined the exit position for the piping bundle. The unit has three knockouts available for the left, right, and bottom exits. When the bundle exits directly from the rear, none of the knockouts are used.

- 1 If the pipes will exit directly from the rear, skip to step 3. Otherwise, cut out the appropriate knockout piece (left, right, or bottom).
- 2 Use a razor knife to clean the cut edges (flashing).
- 3 The left exit is the only position that does not require bending the pipes. For other positions, bend the pipes so that they will exit in the selected exit position.
 - The bending radius should be greater than 100 mm.
 - Bend the smaller pipe gradually to prevent kinking. The larger pipe has a preinstalled spring bender to prevent kinking.
 - Make sure that the pipes do not protrude from the back of the unit in a way that will make it difficult to attach the unit to the mounting bracket.
 - For right and bottom exits, pull the pipes out through the selected knockout opening. For left exits, the piping connections will be made in the service space behind the indoor unit (under the cover panel).

NOTE

- If you are using the right rear exit, the pipes should be long enough to extend through the wall without needing to connect the line set first. It may be easier to connect the line set outside of the building, after you have bundled the pipes and cables and passed the bundle through the wall. In this case, do not connect the line set now. Instead, complete Step 9 through Step 12, then go outside and connect the line set as described below.

- 4 Slowly remove the protective caps on the refrigerant pipe connections to relieve the nitrogen holding charge.
- 5 Connect the line set to each pipe.

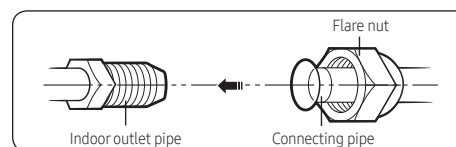

Installation

Wall Mounted Type CNH18/24ADB(AC018/024BNADCH/AA)

- 6 Hand-tighten the flare nuts to make sure that they do not become stripped.

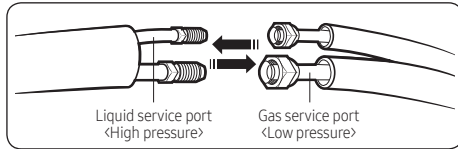

- 7 Torque the flare connections to the following values:

Outer diameter (inch (mm))	Torque (lbf•ft (N•m))	Torque (kgf•cm)
Ø1/4" (6.35)	10.3 to 13.3 (14 to 18)	140~180
Ø3/8" (9.52)	25.1 to 31.0 (34 to 42)	350~430
Ø1/2" (12.70)	36.1 to 45.0 (49 to 61)	500~620
Ø5/8" (15.88)	50.2 to 60.5 (68 to 82)	690~830

CAUTION

- Tighten the flare nuts only to the specified torque. If a flare nut is overtightened, the flare face may crack, causing refrigerant leakage.
- 8 Do not box in or cover the pipe connections. Make sure that the connections are accessible for testing later in the installation process and for future servicing.
- 9 Tape over the end of the pipes so that debris will not enter the piping when it is passed through the wall. The pipes will be insulated later in the installation process.

Connecting the drain hose

- 1 In Step 4 you determined the exit position for the piping bundle. If using the right, bottom, or right rear exit, change the drain hose connection from the right to the left so that the drain hose will lie along the inside of the unit and exit to the right.

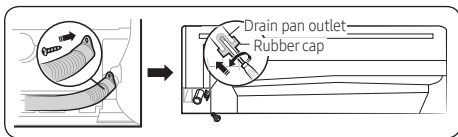

CAUTION

- Be careful not to puncture the plug with the screwdriver when installing it.
- 2 If using the left, right, or bottom exit, pass the drain hose through the selected knockout.

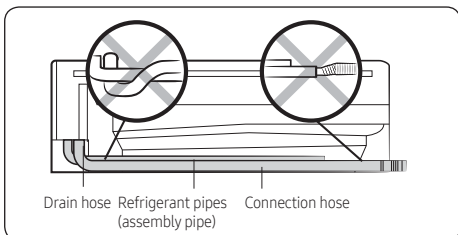

- 3 Connect a 0.63inch (15.88mm) ID extension drain hose to the main drain hose.

CAUTION

- If the diameter of the connection hose is smaller than the product's drain hose, leakage may occur.

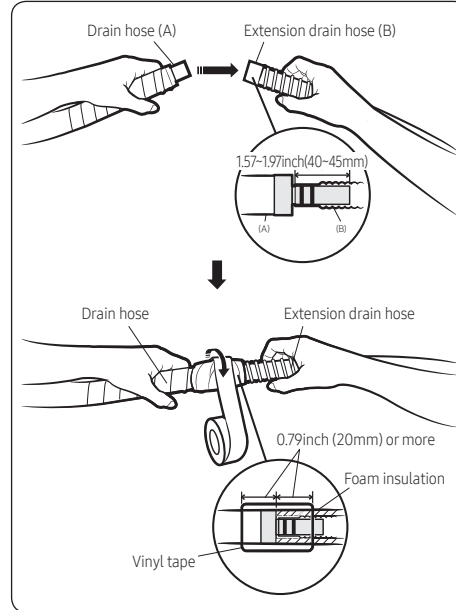

- 4 Do not box in or cover the drain hose connection. It must be accessible for testing later in the installation process and for future servicing.
- 5 If the drain hose is routed inside the room, insulate the hose so that dripping condensation does not damage the furniture or floors.

Connecting the power and communication cables

CAUTION

- Always remember to connect the refrigerant pipes before performing the electric connections. When disconnecting the system, always disconnect the electric cables before disconnecting the refrigerant pipes.
- Always remember to connect the air conditioner to the grounding system before performing the electric connections. Use a crimp ring terminal at the end of each wire.

The indoor unit is powered through the outdoor unit by means of a H05 RN-F connection cable (or a more power model), with insulation in synthetic rubber and a jacket in polychloroprene (neoprene), in accordance with the requirements specified in the standard EN 60335-2-40.

- Remove the screw on the electrical component box and remove the cover plate.
- Route the connection cord through the side of the indoor unit and connect the cable to the terminals refer to the figure below.
- Route the other end of the cable to the outdoor unit through the ceiling & the hole on the wall.
- Reassemble the electrical component box cover, carefully tightening the screw.

Installation

Wall Mounted Type CNH18/24ADB(AC018/024BNADCH/AA)

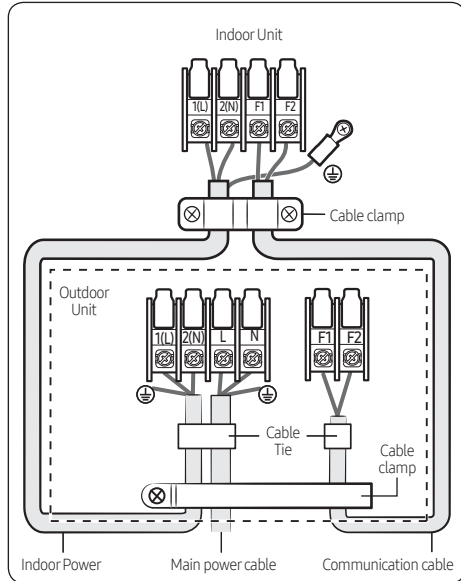

Indoor power supply		
Power supply	Max/Min(V)	Indoor power cable
208 to 230V, 60Hz	±10%	0.0012in ² ↑(0.75mm ² ↑), 3 wires
Communication cable		
0.0012in ² ↑(0.75mm ² ↑), 2 wires		

(Unit: inch (mm))

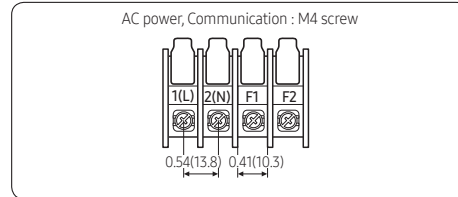

	Tightening torque	
	N-m	lbf.ft
M3.5	0.8 to 1.2	0.59 to 0.89
M4	1.2 to 1.8	0.89 to 1.1

(1N-m=10kgf-cm)

- Power supply cords of parts of appliances for outdoor use shall not be lighter than polychloroprene sheathed flexible cord. (Code designation IEC:60245 IEC 57 / CENELEC: H05RN-F)
- Since it has the external power supply, refer to the outdoor unit installation manual for MAIN POWER.

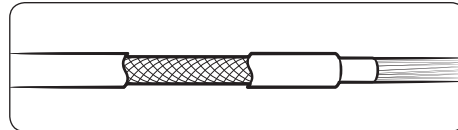

⚠ CAUTION

- When installing the indoor unit in a computer room or network room, use the double shielded communication cable (tape aluminum / polyester braid + copper) of FROHH2R type.

Installation

Wall Mounted Type CNH30/36TDB(AC030/036BNTDCH/AA)

Choosing the installation location

Installation location requirements

- There must be no obstacles near the air inlet and outlet.
- Install the indoor unit on a ceiling that can support its weight.
- Maintain sufficient clearance around the indoor unit.
- Before installing the indoor unit, be sure to check whether the chosen location is well-drained.

WARNING

- Minimum installation height of indoor unit is 0.6 m for floor mounted, 1.8 m for wall, 2.2 m for ceiling.

CAUTION

Do not install the air conditioner in following places.

- The place where there is mineral oil or arsenic acid. Resin parts flame and the accessories may drop or water may leak. The capacity of the heat exchanger may reduce or the air conditioner may be out of order.
- The place where corrosive gas such as sulfurous acid gas generates from the vent pipe or air outlet. The copper pipe or connection pipe may corrode and refrigerant may leak.
- The place where there is a machine that generates electromagnetic waves. The air conditioner may not operate normally due to control system.
- The place where there is a danger of existing combustible gas, carbon fiber or flammable dust.
- The place where thinner or gasoline is handled. Gas may leak and it may cause fire.
- The place where animals may urinate on the product. Ammonia may be generated.
- The place where is close to heat sources.

Overview of installation location requirements

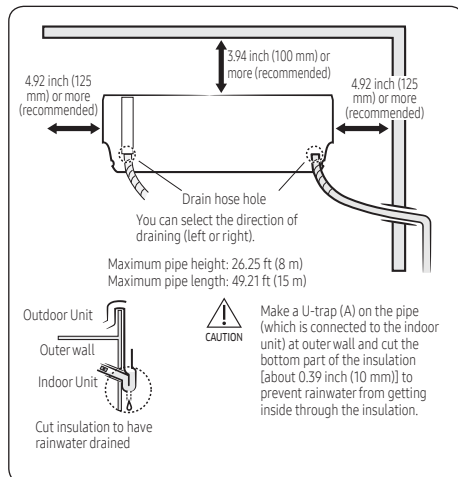

Drilling a hole through the wall

Before fixing the installation plate to a wall and then fixing the indoor unit to the installation plate, a window frame, or a gypsum board, you must determine the position of a hole [with 2.56 inch (65 mm) inner diameter] through which the pipe bundle (consisting of power and communication cables, refrigerant pipes, and drain hose) will pass and then drill that hole.

- 1 Determine the position of a 2.56 inch (65 mm) hole in consideration of the possible directions of the pipe bundle and the minimum distances between the hole and the installation plate.

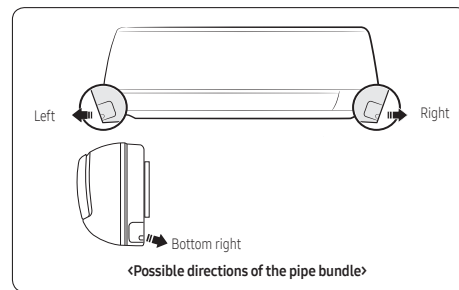

CAUTION

- If changing the pipe direction from left to right, do not drastically bent it but slowly turn it in the opposite direction as shown. Otherwise, the pipe may be damaged in the process.

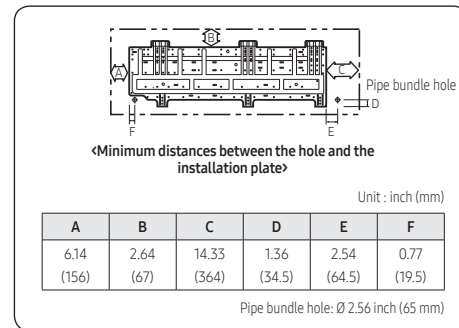

- 2 Drill the hole.

CAUTION

- Be sure to drill only one hole.
- Make sure that the hole slants downwards so that the drain hose slants downwards to drain water well.

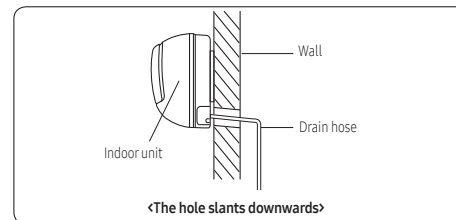

Installation

Wall Mounted Type CNH30/36TDB(AC030/036BNTDCH/AA)

Fixing the installation plate

You can install the indoor unit on a wall, window frame, or gypsum board.

WARNING

- Make sure that the wall, window frame, or gypsum board can withstand the weight of the indoor unit. If you install the indoor unit in a place where it is not strong enough to withstand the unit's weight, the unit could fall and cause injury.

When fixing the indoor unit on a wall

Fix the installation plate to the wall giving attention to the weight of the indoor unit.

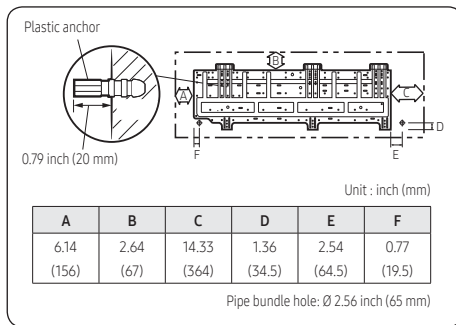

NOTE

- If you mount the plate to a concrete wall using plastic anchors, make sure that gaps between the wall and the plate, created by projected anchor, is less than 0.79 inch (20 mm).

When fixing the indoor unit on a window frame

- Determine the positions of the wooden uprights to be attached to the window frame.
- Attach the wooden uprights to the window frame giving attention to the weight of the indoor unit.
- Attach the installation plate to the wooden upright using tapping screws.

When fixing the indoor unit on a gypsum board

- Use stud finder to find out locations of the studs.
- Fix the plate hanger on two studs.

CAUTION

- If you fix the indoor unit on a gypsum board, use only specified anchor bolts on reference positions. Otherwise, the gypsum surrounding the joints may crumble over time and cause the screws to be loosened and stripped. This may lead to physical injury or equipment damage.
- Search for other spots if there are less than two studs, or the distance between the studs are different from the plate hanger.
- Fix the installation plate without inclining to one side.

Connecting the refrigerant pipe

Connect indoor and outdoor units with field-supplied copper pipes by means of flare connections. Use insulated seamless refrigeration grade pipe only, (Cu DHP type according to ISO1337), degreased and deoxidized, suitable for operating pressures of at least 4200 kPa and for burst pressure of at least 20700 kPa. Under no circumstances must sanitary type copper pipe be used.

There are 2 refrigerant pipes of different diameters:

- The smaller one is for the liquid refrigerant
- The larger one is for the gas refrigerant

A short pipe is already fitted to the air conditioner. You may need to extend the pipe using the assembly pipe. (optional)

The connection procedure for the refrigerant pipe varies according to the exit position of the pipe when facing the wall:

- Left(A)
- Right(B)
- Rear

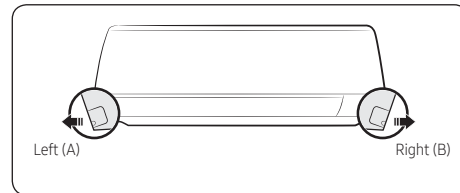

- Cut out the appropriate knock-out piece on the rear of the indoor unit unless you connect the pipe directly from the rear.
- Smooth the cut edges.
- Remove the protection caps of the pipes and connect the assembly pipe to each pipe. Tighten the nuts first with your hands, and then with a torque wrench, applying the following torque:

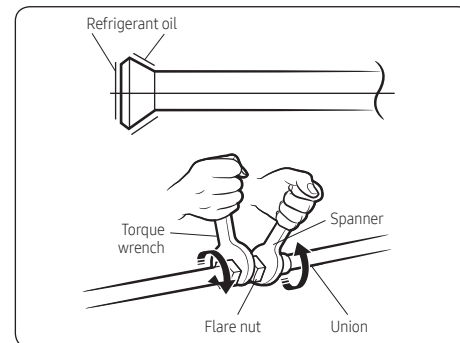

Outer diameter (inch (mm))	Torque (lb•ft (N•m))	Torque (kgf•cm)
\varnothing 1/4 (6.35)	10.3 to 13.3 (14 to 18)	140~180
\varnothing 3/8 (9.52)	25.1 to 31.0 (34 to 42)	350~430
\varnothing 1/2 (12.70)	36.1 to 45.0 (49 to 61)	500~620
\varnothing 5/8 (15.88)	50.2 to 60.5 (68 to 82)	690~830

NOTE

- If you want to shorten or extend pipes, refer to Step 6 Cutting or flaring the pipes.

Installation

Wall Mounted Type CNH30/36TDB(AC030/036BNTDCH/AA)

- 4 Cut off the remaining foam insulation.
- 5 If necessary, bend the pipe to fit along the bottom of the indoor unit. Then pull it out through the appropriate hole.
 - The pipe should not project from the rear of the indoor unit.
 - The bending radius should be 3.94 inch (100 mm) or more.
- 6 Pass the pipe through the hole in the wall.
- 7 For further details on how to connect to the outdoor unit and purge the air, refer to Step 4 Purging the unit.

NOTE

- The pipe will be insulated and fixed permanently into position after finishing the installation and the gas leak test; refer to page 10 for further details.
- DO NOT WALL UP THE PIPE CONNECTION!
All refrigerant pipe connection must be easy accessible and serviceable.

Installing and connecting the drain hose

- 1 Install the drain hose.

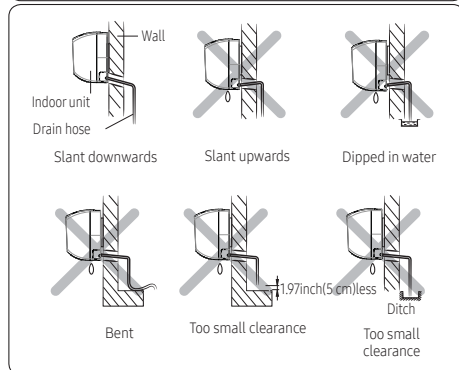
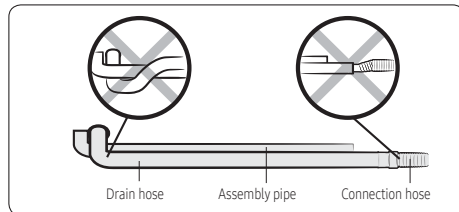

- 2 Pour water into the drain pan. Check whether the hose is well drained.

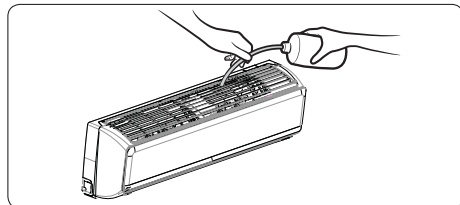

CAUTION

- Make sure that the indoor unit is in upright position when you pour water to check for leakage. Make sure that the water does not overflow onto the electrical part.
- If the diameter of the connection hose is smaller than the product's drain hose, water leakage may occur.

- Inadequate installation may cause water leakage.
- If the drain hose is routed inside the room, insulate the hose so that dripping condensation does not damage the furniture or floors.
- Do not box in or cover the drain hose connection. Drain hose connection must be easily accessible and serviceable.

Optional: Extending the drain hose

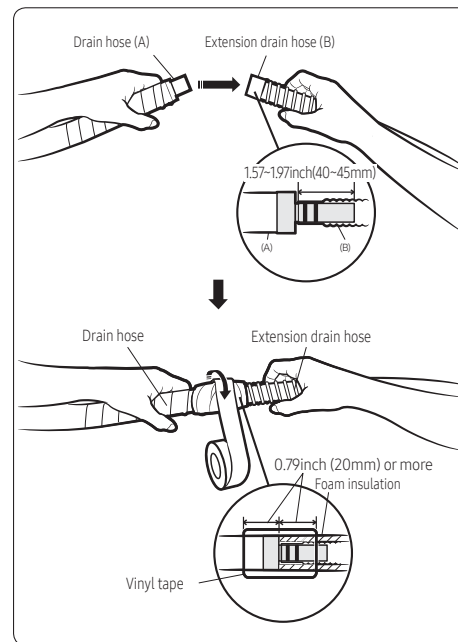

Optional: Changing the direction of the drain hose

Change the direction only when it is necessary.

- 1 Detach the rubber cap with the flyer.

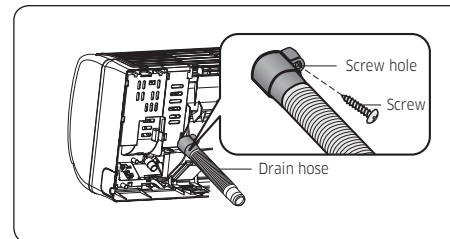

- 2 Detach the drain hose by pulling it and turning to the left.
- 3 Insert the drain hose by fixing it into the groove of the drain hose and the outlet of the drain pan.

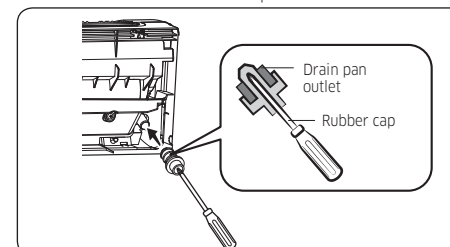

Installation

Wall Mounted Type CNH30/36TDB(AC030/036BNTDCH/AA)

- Attach the rubber cap with a screwdriver by turning it to the right until it fixes to the end of the groove.
- Check for leakage on both side of the drain outlet.

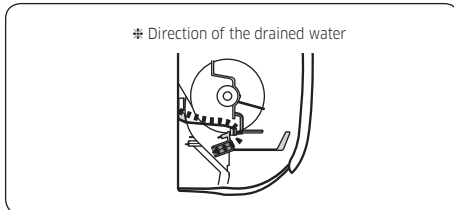
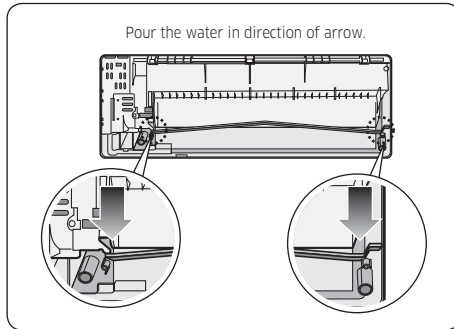

⚠ CAUTION

- Make sure that the indoor unit is in upright position when you pour water to check for leakage. Make sure that the water does not overflow onto the electrical part.

Connecting the power and communication cables

⚠ CAUTION

- Always remember to connect the refrigerant pipes before performing the electric connections. When disconnecting the system, always disconnect the electric cables before disconnecting the refrigerant pipes.
- Always remember to connect the air conditioner to the grounding system before performing the electric connections. Use a crimp ring terminal at the end of each wire.

The indoor unit is powered through the outdoor unit by means of a H05 RN-F connection cable (or a more power model), with insulation in synthetic rubber and a jacket in polychloroprene (neoprene), in accordance with the requirements specified in the standard EN 60335-2-40.

- Remove the screw on the electrical component box and remove the cover plate.
- Route the connection cord through the side of the indoor unit and connect the cable to the terminals refer to the figure below.
- Route the other end of the cable to the outdoor unit through the ceiling & the hole on the wall.
- Reassemble the electrical component box cover, carefully tightening the screw.

⚠ CAUTION

- When installing the indoor unit in a computer room or network room, use the double shielded communication cable (tape aluminum / polyester braid + copper) of FROH2R type.

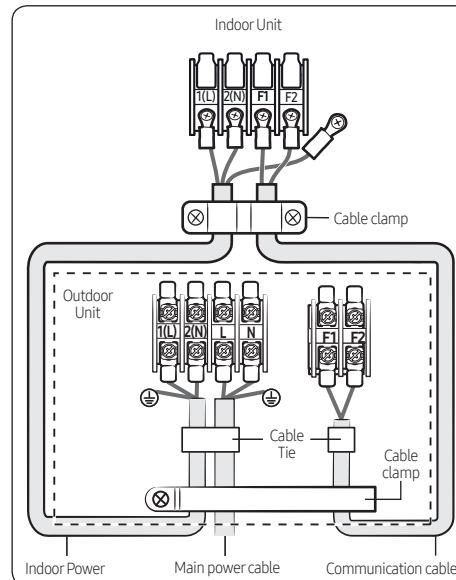

Indoor power supply		
Power supply	Max/Min(V)	Indoor power cable
208 to 230V, 60Hz	±10%	0.0012inch ² ↑(0.75mm ² ↑), 3 wires
Communication cable		
0.0012inch ² ↑(0.75mm ² ↑), 2 wires		

AC power, Communication : M4 screw (Unit: inch (mm))

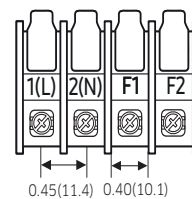

	Tightening torque	
	N-m	lbfft
M3.5	0.8 to 1.2	0.59 to 0.89
M4	1.2 to 1.8	0.89 to 1.1

(1N-m=10kgf-cm)

- Power supply cords of parts of appliances for outdoor use shall not be lighter than polychloroprene sheathed flexible cord. (Code designation IEC:60245 IEC 57 / CENELEC: H05RN-F)
- Since it has the external power supply, refer to the outdoor unit installation manual for MAIN POWER.

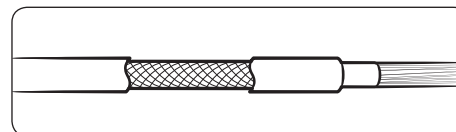

Installation

Outdoor Units

Choosing the installation location

Installation location requirements

- Do not place the outdoor unit on its side or upside down. Failing to do so may cause the compressor lubrication oil to run into the cooling circuit and lead to serious damage to the unit.
- Install the unit in a well-ventilated location away from direct sunlight or strong winds.
- Install the unit in a location that would not obstruct any passageways or thoroughfares.
- Install the unit in a location that would not inconvenience or disturb your neighbors, as they could be affected by the noise or the airflow coming from the unit.
- Install the unit in a location where the pipes and the cables can be easily connected to the indoor unit.
- Install the unit on a flat, stable surface that can withstand the weight of the unit. Otherwise, the unit can generate noise and vibration during operation.
- Install the unit so that the air flow is directed towards the open area.
- Maintain sufficient clearance around the outdoor unit, especially from a radio, computer, stereo system, etc.

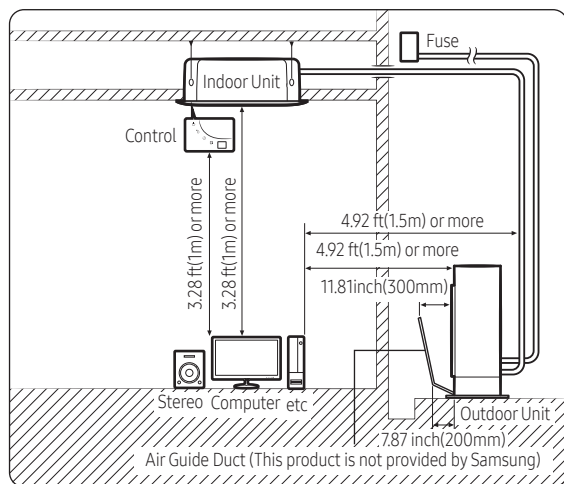

⚠ CAUTION

- You have just purchased a system air conditioner and it has been installed by your installation specialist.
- This device must be installed according to the national electrical rules.
- If your outdoor unit exceeds a net weight of 132.2 lb(60 kg), do not install it on a suspended wall, but stand it on a floor.
- The reliability of our product cannot be guaranteed under conditions of "A" or less.

Outdoor Model	"A"
AC018/024BXSCCC	
AC030/036BXSCCC	-40°F(-40°C)

- When installing the outdoor unit at the seaside, make sure that it is not directly exposed to sea breeze. If you cannot find an adequate place free from direct sea breeze, construct a protection wall or a protective fence.
 - Install the outdoor unit in a place (such as near buildings etc.) where it can be prevented from sea breeze. Failure to do so may cause a damage to the outdoor unit.

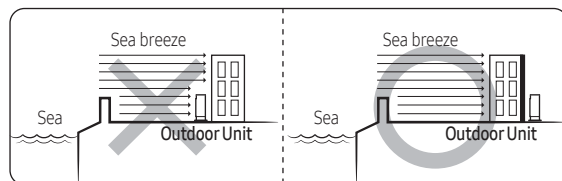

- If you cannot avoid installing the outdoor unit at the seaside, construct a protection wall around to block the sea breeze.
- Construct a protection wall with a solid material such as concrete to block the sea breeze. Make sure that the height and the width of the wall are 1.5 times larger than the size of the outdoor unit. Also, secure a space larger than 27.6 inch(700mm) between the protection wall and the outdoor unit for exhausted air to ventilate.

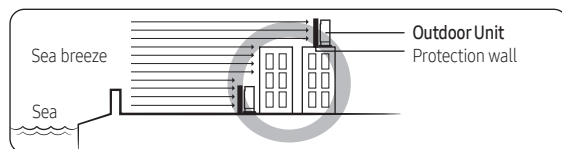

⚠ CAUTION

- Depending on the condition of the power supply, unstable power or voltage may cause malfunction of parts or control system (example: on a boat or places using power supplied from electric generator, etc.).

Installation

Outdoor Units

- Install the unit in a place where water can drain smoothly.
- If you have any difficulty finding installation location as prescribed above, contact your manufacturer for details.
- Consider that the salinity particles clinging to the external panels should be sufficiently washed out. Be sure to clean sea water and dust from the outdoor unit heat exchanger and apply a corrosion inhibitor on it at least once a year.
- Because the residual water at the bottom of the outdoor unit significantly promotes corrosion, make sure that the slope does not disturb drainage.
 - Keep the floor level so that rain does not accumulate.
 - Be careful not to block the drain hole due to foreign substance.
- Check the condition of the product periodically.
 - Check the installation site every 3 months and perform anti-corrosion treatment such as R-Pro supplied by SAMSUNG (Code : MOK-220SA) or commercial water repellent grease and wax, etc., based on the product condition.
 - When the product is to be shut down for a long period of time, such as off-peak hours, take appropriate measures like covering the product.
- If the product installed within 1640.4 ft of seashore, special anti-corrosion treatment is required.
 - ✧ Please contact your local SAMSUNG representative for further details.

CAUTION

- In areas with heavy snow fall, piled snow could block the air intake. To avoid this incident, install a frame that is higher than estimated snow fall. In addition, install a snow-proof hood to avoid snow from piling on the outdoor unit.

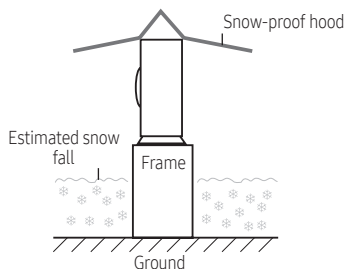

Outdoor unit dimensions

Unit : inch (mm)

A Type
AC018BXSCCC
B Type
AC024BXSCCC
C Type
AC030BXSCCC, AC036BXSCCC

Installation

Outdoor Units

Minimum clearances for the outdoor unit

When installing 1 outdoor unit

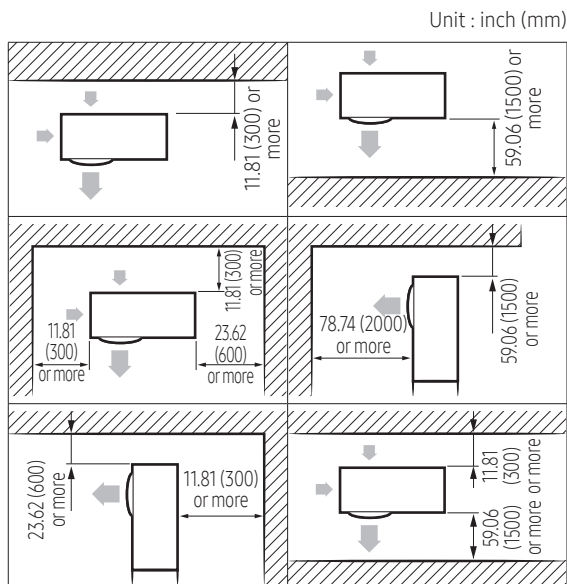

When installing more than 1 outdoor unit

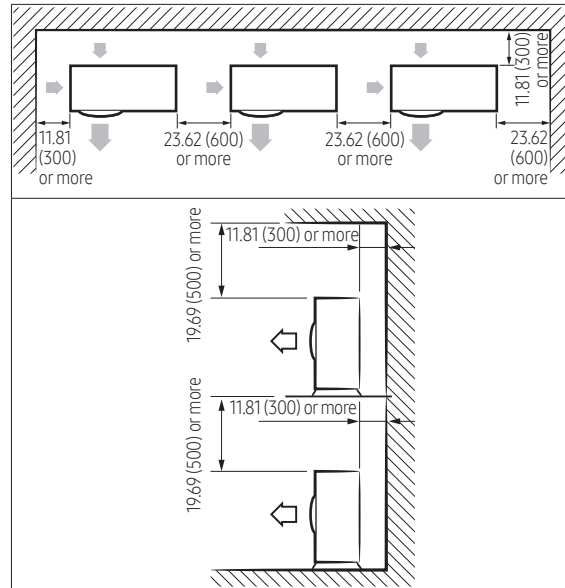
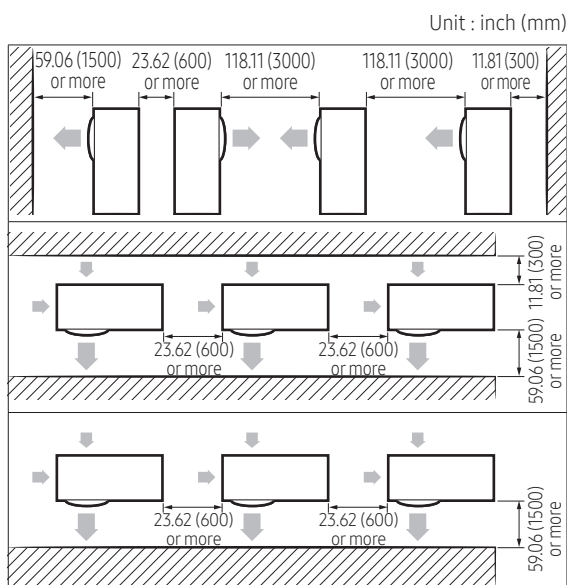

⚠ CAUTION

- The outdoor unit must be installed according to the specified distances in order to permit accessibility from each side, to guarantee correct operation, maintenance, and repair of the unit. The components of the outdoor unit must be reachable and removable under safe conditions for people and the unit.

⚠ WARNING

- Should adopt bar type louver. Don't use a type of rain resistance louver.

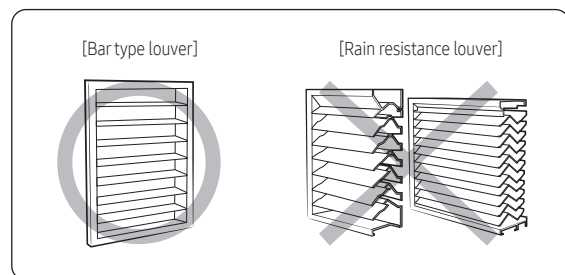

- Louver specifications.
 - Angle criteria : less than 20°
 - Opening ratio criteria : greater than 80%

Installation

Outdoor Units

Moving the outdoor unit with wire rope

- 1 Before carrying the outdoor unit, fasten two wire ropes of 26.25 ft (8m) or longer, as shown in the figure.
- 2 To prevent damages or scratches effectively, insert a piece of cloth between the outdoor unit and the ropes.
- 3 Move the outdoor unit.

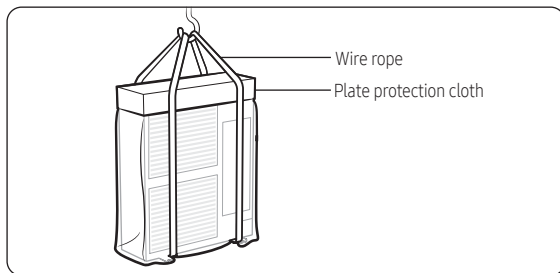
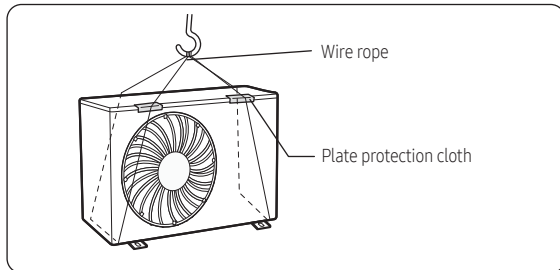

Fixing the outdoor unit in place

Install the outdoor unit on a rigid and stable base to prevent disturbance from any noise caused by vibration. When installing the unit on tall stands or in a location exposed to strong winds, fix the unit securely to the ground or structure.

- 1 Position the outdoor unit so that the air flow is directed towards the outside, as indicated by the arrows on the top of the unit.
- 2 Attach the outdoor unit to the appropriate support using anchor bolts.
 - The ground wire for the telephone line cannot be used to ground the air conditioner.
- 3 If the outdoor unit is exposed to strong winds, install shield plates around the outdoor unit, so that the fan can operate correctly.

NOTE

- Install provided rubber legs to prevent vibration and noise.

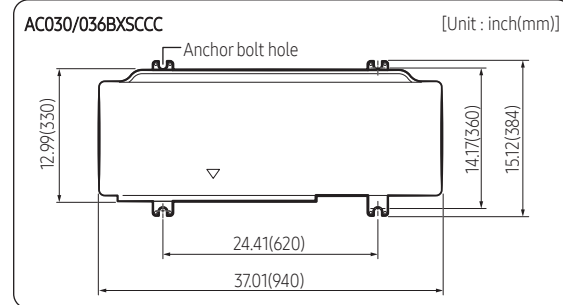
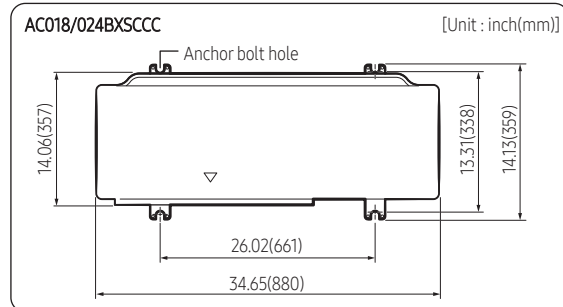

CAUTION

- Install a drain outlet at the lowest end around the base for outdoor unit drainage
- When installing the outdoor unit on the roof, waterproof the unit and check the ceiling strength.

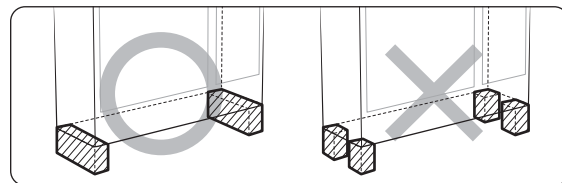

Optional: Fixing the outdoor unit to a wall with a rack

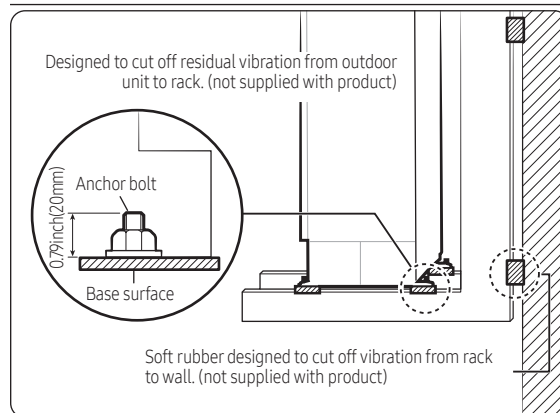

- Install a proper grommet in order to reduce noise and residual vibration transferred by the outdoor unit towards the wall.

Installation

Outdoor Units

⚠ CAUTION

- Make sure that the wall can support the weights of the rack and the outdoor unit.
- Install the rack close to the column as much as possible.
- When installing an air guide duct, be sure to check the following:
 - The screws do not damage the copper pipe.
 - The air guide duct is fixed firmly on the guard fan.

Connecting the power cables, communication cable, and controllers

You must connect the following three electrical cables to the outdoor unit:

- The main power cable between the auxiliary circuit breaker and the outdoor unit.
- The outdoor-to-indoor power cable between the outdoor unit and the indoor unit.
- The communication cable between the outdoor unit and the indoor unit.

⚠ CAUTION

- During installation, make first the refrigerant connections and then the electrical connections. If the unit is being removed, first disconnect the electrical cables and then the refrigerant connections.
- Connect the air conditioner to the earthing system before making the electrical connections.

Connecting wire conduits

When connecting cables between the indoor unit and the outdoor unit, use conduits to protect the cables.

- 1 Drill holes on the conduit plate in accordance with their use and quantity.
 - AC018/024BXSCC
 - Drill conduit holes on the side cabinet. (knock out holes)

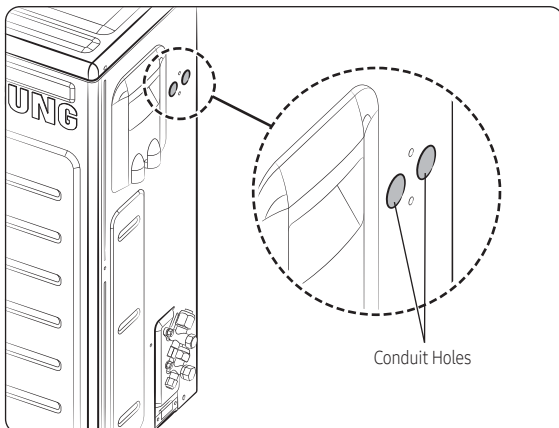

- AC030/036BXSCC
 - Use a nipper to remove conduit holes from the lower part of the cabinet. (Do not remove it by hammering.)

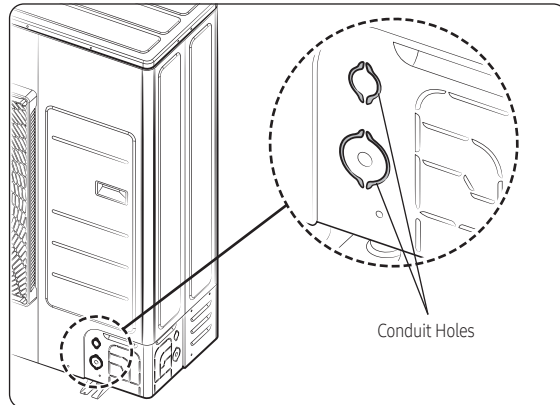

- 2 Insert the cables through the conduits, and then fix the conduits to the conduit plate with the lock nuts.
- 3 Apply silicone to the end of the hose to prevent rain from entering the hose.

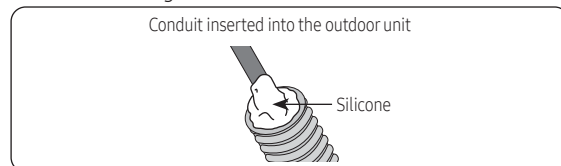

- 4 Connect the cables to the outdoor units. For how to connect the cables, refer to the next page.
- 5 Attach the conduit plate to the product.

Air conditioning system examples

When using earth leakage circuit breaker (ELCB) for a single phase

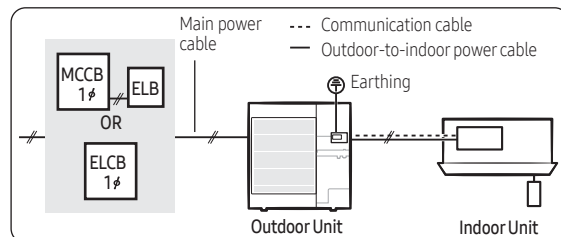

※ The appearance of the unit may be different from the picture depending on the model.

⚠ CAUTION

- If the outdoor unit is installed in a location vulnerable to an electric leak or submergence, make sure to install an ELCB.

Installation

Outdoor Units

Connecting the main power cable

When using ELB for AC018/024BXSCC (1-phase)

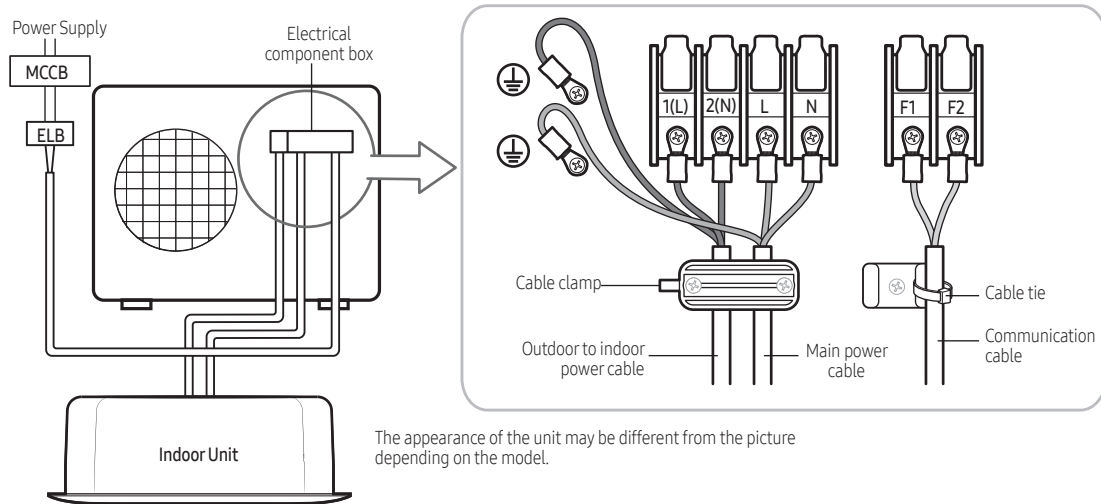

When using ELB for AC030/036BXSCC (1-phase)

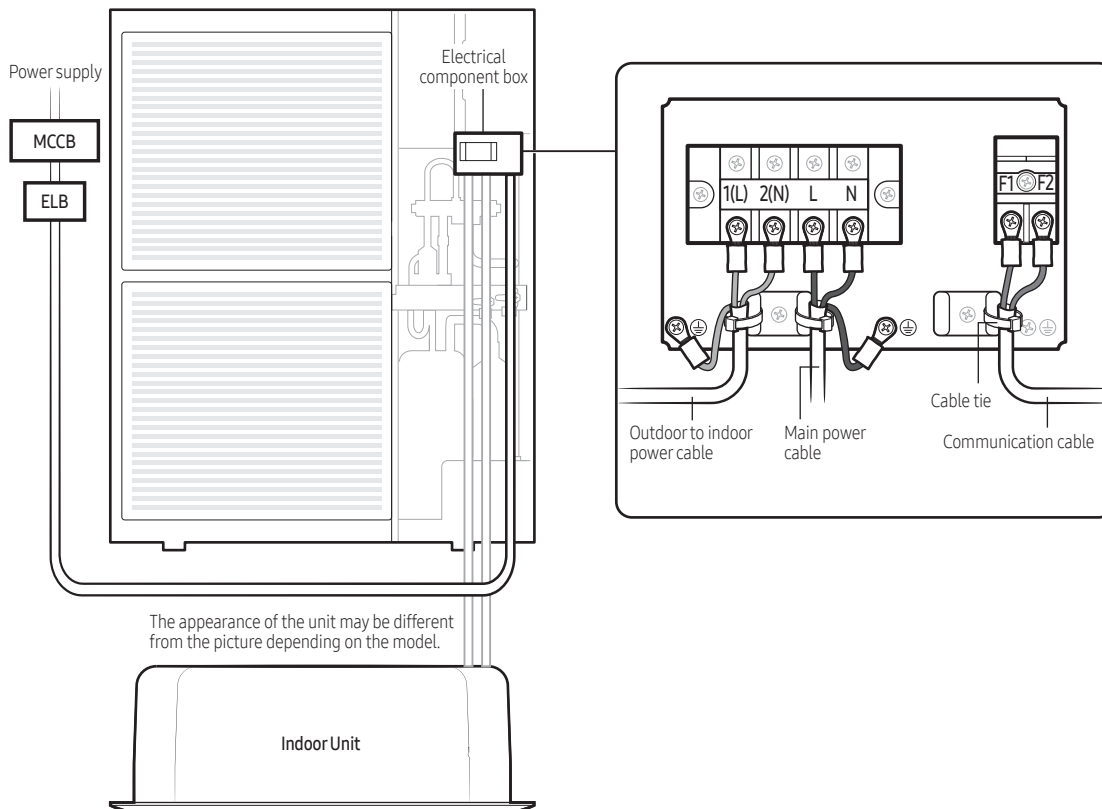

Installation

Outdoor Units

⚠ CAUTION

- You should connect the power cable into the power cable terminal and fasten it with a clamp.
- The unbalanced power must be maintained within 2% of supply rating.
- If the power is unbalanced greatly, it may shorten the life of the condenser. If the unbalanced power is exceeded over 4% of supply rating, the indoor unit is protected, stopped and the error mode indicates.
- To protect the product from water and possible shock, you should keep the power cable and the connection cord of the indoor and outdoor units within ducts. (with appropriate IP rating and material selection for your application)
- Ensure that main supply connection is made through a switch that disconnects all poles, with contact gap of a least 0.12 inch(3mm).
- Devices disconnected from the power supply should be completely disconnected in the condition of overvoltage category.
- Keep distances of 1.97 inch(50mm) or more between power cable and communication cable.

Main power terminal block specifications

- AC018/024BXSCCC (1-phase)

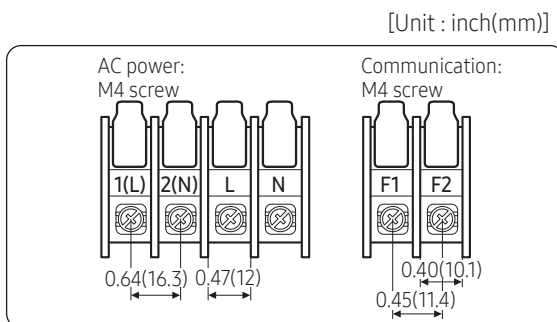

- AC030/036BXSCCC (1-phase)

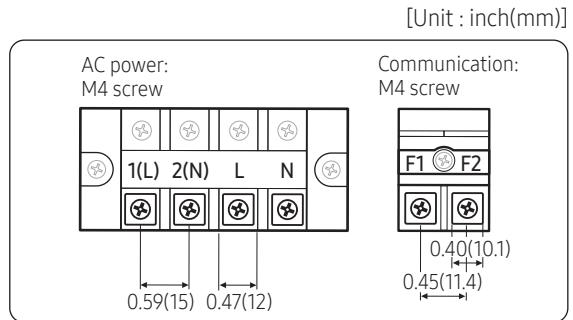

Main power cable specifications

The power cable is not supplied with air conditioner.

- Select the power supply cable in accordance with relevant local and national regulations.
- Wire size must comply with the applicable local and national code.
- Specifications for local wiring power cord and branch wiring are in compliance with local cord.

Installation

Outdoor Units

Model		Power Source	RLA (A)	Outdoor		Indoor	MCA (A)	MOP (A)			
Outdoor	Indoor			MOC		Rated input current of the power conversion equipment					
				FAN1(A)	FAN2(A)	FAN(A)					
AC018BXSCCC	AC018BN4DCH	208-230V/60Hz	8.2	0.97	-	0.79	12.2	15.0			
	AC018BNADCH					0.42	11.8	15.0			
	AC018BNHDCH					2.10	13.5	15.0			
AC024BXSCCC	AC024BN4DCH		208-230V/60Hz	13.5	0.97	-	0.79	18.8	25.0		
	AC024BNADCH						0.42	18.4	25.0		
	AC024BNHDCH						2.10	20.1	25.0		
AC030BXSCCC	AC030BN4DCH			208-230V/60Hz	16.2	0.97	-	0.79	22.2	30.0	
	AC030BNHDCH							2.10	23.5	30.0	
	AC030BNTDCH							0.51	21.9	30.0	
AC036BXSCCC	AC036BN4DCH				208-230V/60Hz	16.2	0.97	-	0.79	22.2	30.0
	AC036BNHDCH								3.50	24.9	30.0
	AC036BNTDCH								0.51	21.9	30.0

Installation

Outdoor Units

NOTE

- RLA is based on AHRI 210/240 cooling standard condition [Indoor temp. : 26.7 °C / 80 °F(DB) / 19.46 °C / 67 °F(WB), Outdoor temp. : 35 °C / 95 °F(DB)]
- Voltage tolerance is $\pm 10\%$.
- Maximum allowable voltage between phases is 2%.
- **Symbols**
 - RLA: Rated Load Ampere (A)
 - MOC: Maximum Operating Current (A)
 - MCA: Minimum Circuit Ampere (A)
 - MOP: Maximum Overcurrent Protective Device (A)
- Voltage range
 - Units are suitable for use on electrical systems where voltage supplied to unit terminal is not below or above listed range limits.
- Maximum allowable voltage variation between phases is 2%.
- Wire size & type must comply with the applicable local and national code.
 - Wire size: Based on the value of MCA.
 - Wire type:
 - 1-phase: 60245 IEC57(IEC) or H05RN-F(CENELEC) grade or more

Silence mode controller wiring diagram with External controller

- AC018/024BXSCCC

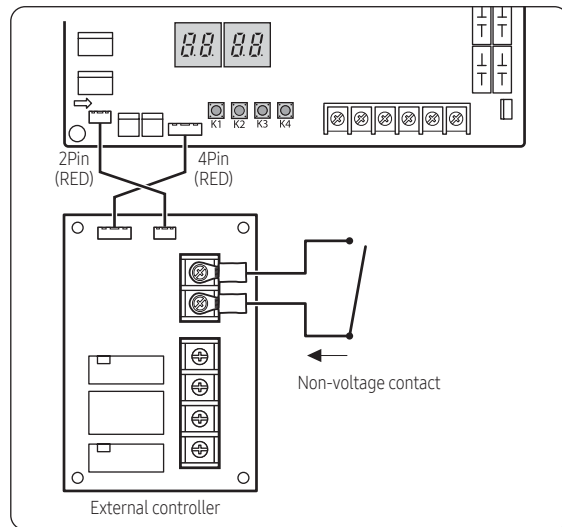

- AC030/036BXSCCC

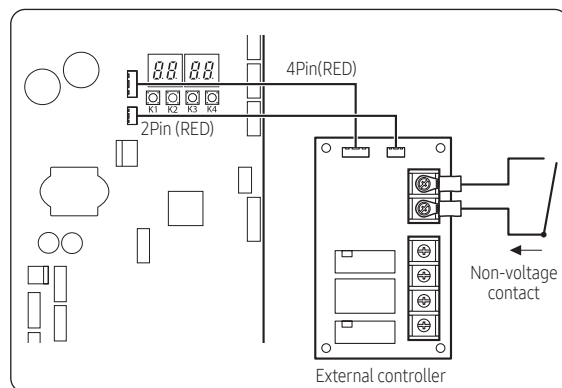

Installation

Outdoor Units

Connecting the outdoor-to-indoor power cable and the communication cable

- AC018/024BXSCCC

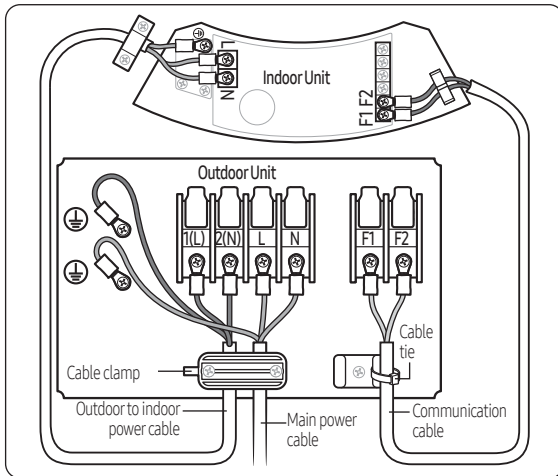

- AC030/036BXSCCC

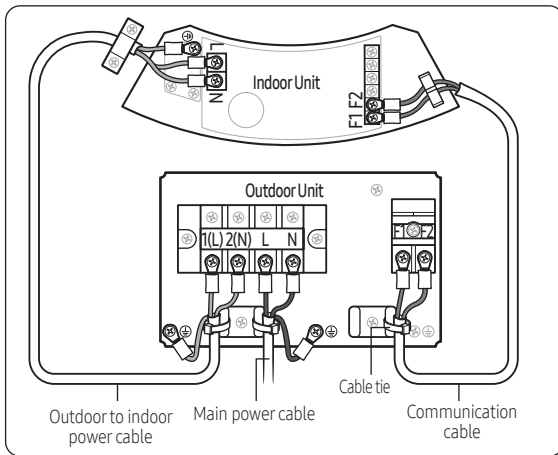

NOTE

- Lay the electrical wiring so that the front cover does not rise up when doing wiring work and attach the front cover securely.
- Ground wire for the indoor unit and outdoor unit connection cable must be clamped to a soft copper tin-plated eyelet terminal with M4 screw hole (NOT SUPPLIED WITH UNIT ACCESSORIES).
- The appearance of the unit may be different from the picture depending on the model.

Outdoor-to-indoor power terminal specifications

- Connect the cables to the terminal board using the compressed ring terminal.
- Cover a solderless ring terminal and a connector part of the power cable and then connect it.

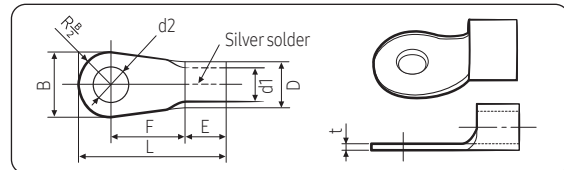

Installation

Outdoor Units

Nominal dimensions for cable [mm ² (inch ²)]	Nominal dimensions for screw [mm(inch)]	B		D		d1		E [mm (inch)]	F		L [mm (inch)]	d2		t [mm (inch)]
		Standard dimension [mm(inch)]	Allowance [mm(inch)]	Standard dimension [mm(inch)]	Allowance [mm(inch)]	Standard dimension [mm(inch)]	Allowance [mm(inch)]		Min. [mm (inch)]	Min. [mm (inch)]		Max. [mm (inch)]	Standard dimension [mm(inch)]	
4/6 (0.006/ 0.009)	4(3/8)	9.5(3/8)	±0.2 (±0.007)	5.6(1/4)	+0.3(+0.011) -0.2(-0.007)	3.4(1/8)	±0.2 (±0.007)	6 (1/4)	5 (3/16)	20 (3/4)	4.3 (3/16)	+0.2 (+0.007) 0(0)	0.9 (0.03)	
	8(3/16)	15(9/16)							28.5 (1-1/8)	8.4 (1-3/16)		+0.4 (+0.015) 0(0)		
10(0.01)	8(3/16)	15(9/16)	±0.2 (±0.007)	7.1(1/4)	+0.3(+0.011) -0.2(-0.007)	4.5(3/16)	±0.2 (±0.007)	7.9 (5/16)	9 (3/8)	30 (1-3/16)	8.4 (1-3/16)	+0.4 (+0.015) 0(0)	1.15 (0.04)	
16(0.02)	8(3/16)	16(10/16)	±0.2 (±0.007)	9(3/8)	+0.3(+0.011) -0.2(-0.007)	5.8(1/4)	±0.2 (±0.007)	9.5 (5/16)	13 (1/2)	33 (1-5/16)	8.4 (1-3/16)	+0.4 (+0.015) 0(0)	1.45 (0.05)	
25(0.03)	8(3/16)	12(1/2)	±0.3 (±0.011)	11.5(7/16)	+0.5(+0.019) -0.2(-0.007)	7.7(5/16)	±0.2 (±0.007)	11 (3/8)	15 (5/8)	34 (1- 3/8)	8.4 (1-3/16)	+0.4 (+0.015) 0(0)	1.7 (0.06)	
	8(3/16)	16.5(10/16)							13 (1/2)	8.4 (1-3/16)		0(0)		
35(0.05)	8(3/16)	16(10/16)	±0.3 (±0.011)	13.3(1/2)	+0.5(+0.019) -0.2(-0.007)	9.4(3/8)	±0.2 (±0.007)	12.5 (1/2)	13 (1/2)	38 (1-1/2)	8.4 (1-3/16)	+0.4 (+0.015) 0(0)	1.8 (0.07)	
	8(3/16)	22(7/8)							13 (1/2)	43 (1- 11/16)		8.4 (1-3/16)		0(0)
50(0.07)	8(3/16)	22(7/8)	±0.3 (±0.011)	13.5(1/2)	+0.5(+0.019) -0.2(-0.007)	11.4(7/16)	±0.3 (±0.011)	17.5 (11/16)	14 (9/16)	50 (2)	8.4 (1-3/16)	+0.4(+0.015) 0(0)	1.8 (0.07)	
70(0.10)	8(3/16)	24(1)	±0.4 (±0.015)	17.5(11/16)	+0.5(+0.019) -0.4(-0.015)	13.3(1/2)	±0.4 (±0.015)	18.5 (3/4)	20 (3/4)	51 (2)	8.4 (1-3/16)	+0.4(+0.015) 0(0)	2.0 (0.078)	

- Connect the rated cables only.
- Connect using a driver which is able to apply the rated torque to the screws.
- If the terminal is loose, fire may occur caused by arc. If the terminal is connected too firmly, the terminal may be damaged.

	Tightening torque	
	lbf•ft	N•m
M4	0.87 to 1.30	0.8 to 1.2
M5	1.45 to 2.17	2.0 to 3.0

CAUTION

- When connecting cables, you can connect the cables to the electrical part or connect them through the holes below depending on the spot.
- Connect the communication cable between the indoor and outdoor units through a conduit to protect against external forces, and feed the conduit through the wall together with refrigerant piping.
- Remove all burrs at the edge of the knock-out hole and secure the cable to the outdoor knock-out using lining and bushing with an electrical insulation such as rubber and so on.
- Must keep the cable in a protection tube.
- Keep distances of 1.97 inch(50mm) or more between power cable and communication cable.
- When the cables are connected through the hole, remove the Plate bottom.

Installation

Outdoor Units

Outdoor-to-indoor power and communication cables specifications

- Indoor unit :
4WAY CST(AC***BN4***)
Mini4way CST(AC***BNN***)
- Indoor unit :
Duct(AC***BNL***, AC***BNH***)
- Indoor unit :
RAC(AC***BNT***, AC***BNA***)

Indoor power supply		
Power supply	Max/Min (V)	Indoor power cable
1Φ, 208-230V~, 60Hz	±10%	0.0012 inch ² ↑ (0.75mm ² ↑), 3 wires
Communication cable		
0.0012 inch ² ↑ (0.75mm ² ↑), 2 wires		

- Power supply cords of parts of appliances for outdoor use shall not be lighter than polychloroprene sheathed flexible cord. (Code designation IEC:60245 IEC 57 / CENELEC: H05RN-F)
- When installing the indoor unit in a computer room or network room, use the double shielded (tape aluminum / polyester braid + copper) cable of FROHH2R type.

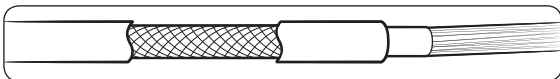



2022.02
Ver.1.1

Samsung Electronics Co., LTD.

Head Office (Suwon Korea) 129, Samsung-Ro, Yeongtong-Gu, Suwon City, Gyeonggi-Do, Korea 16677
Website : www.samsung.com, <https://partnerhub.samsung.com> Email : airconditioner@samsung.com
Images and data in this book may subject to change without prior notice.