



A421 Series Electronic Temperature Controls with Off-Cycle Defrost Installation Guide

Applications

- ▶ **Important:** Use this A421 Series Electronic Temperature Control only as an operating control. Where failure or malfunction of the A421 Control could lead to personal injury or property damage to the controlled equipment or other property, additional precautions must be designed into the control system. Incorporate and maintain other devices, such as supervisory or alarm systems or safety or limit controls, intended to warn of or protect against failure or malfunction of the A421 Control.
- ▶ **Important:** Utiliser ce A421 Series Electronic Temperature Control uniquement en tant que dispositif de régulation. Lorsqu'une défaillance ou un dysfonctionnement du A421 Control risque de provoquer des blessures ou d'endommager l'équipement contrôlé ou un autre équipement, la conception du système de contrôle doit intégrer des dispositifs de protection supplémentaires. Veiller dans ce cas à intégrer de façon permanente d'autres dispositifs, tels que des systèmes de supervision ou d'alarme, ou des dispositifs de sécurité ou de limitation, ayant une fonction d'avertissement ou de protection en cas de défaillance ou de dysfonctionnement du A421 Control.

The A421 Series Electronic Temperature Controls are single-stage, electronic temperature controls with a single-pole, double-throw (SPDT) output relay.

A421 Controls feature a backlit LCD with adjustable brightness and three-button touchpad interface that you can set up to restrict user adjustments. An LED indicates the output relay's on/off status.

A421 Controls have simple on and off temperature settings for heating or cooling, an adjustable anti-short cycle delay, temperature setback, and sensor offset capability. The temperature control range is -40°F to 212°F or -40°C to 100°C.

The A421 Controls are available either in Type 1 (NEMA), IP20 (CE), high-impact plastic enclosures suitable for surface or DIN rail mounting (Figure 1), or in Type 4X (NEMA), IP66 (CE) watertight, corrosion resistant surface mount enclosures (Figure 2).

Dimensions

Figure 1: A421 Control with Type 1 (NEMA), IP20 enclosure dimensions, in. (mm)

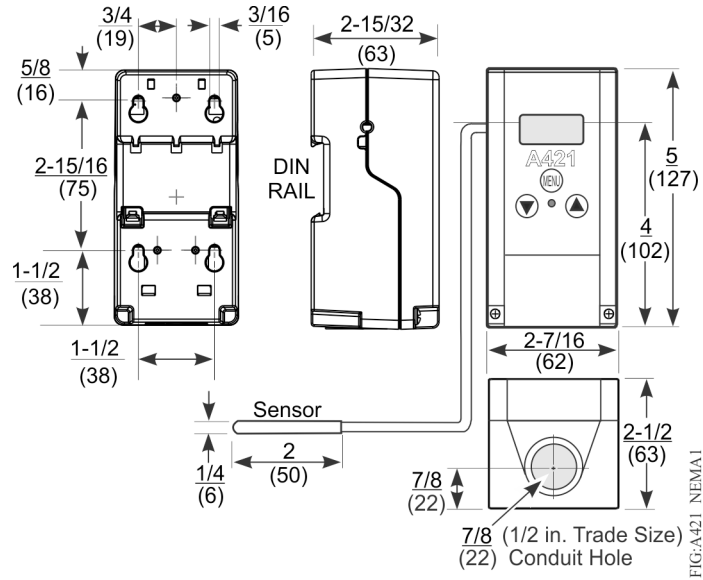
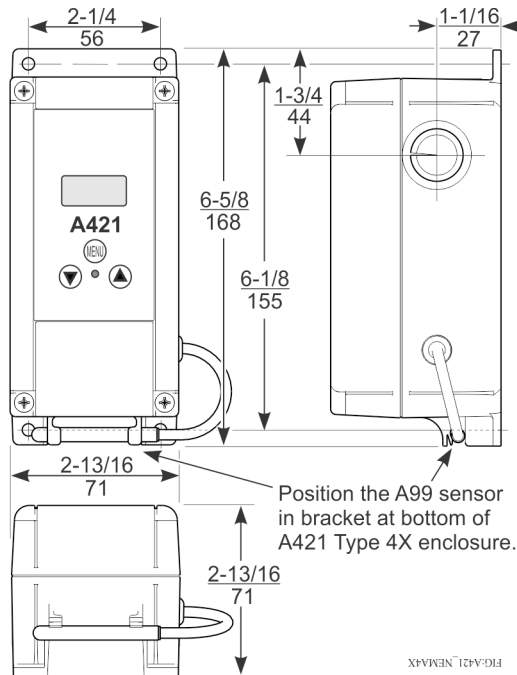

Figure 2: A421 Control with Type 4X (NEMA), IP66 enclosure dimensions, in. (mm)



Off-Cycle Defrost control

You can use the A421 Control with Off-Cycle Defrost to set up regular, passive defrost periods of 1 minutes to 99 minutes. The defrost interval can range from 2 hours to 24 hours, or you can set it to 0 for no defrost interval. You can also start or stop a defrost cycle in the following two ways: use the three-button touchpad on the Advanced Menu or connect a momentary switch to the binary input (BI).

The A421 with Defrost Control is typically used to provide temperature control and adjustable, timed, passive defrost cycles on medium temperature cooling applications such as reach-in boxes, display cases, and walk-in coolers.

Parts included

Each A421 Control includes a Johnson Controls® or PENN® A99 Series temperature sensor. See [A99 Series Temperature Sensors](#), [Wiring](#), and [Technical specifications](#) for more information about A99 sensors.

A99 Series Temperature Sensors

The A421 Controls require an A99 sensor, and each A421 Control includes an A99 sensor. Any A99 Series sensor works with the A421 Series Controls. Do not replace an A99 Series sensor with any other brand, series, or type of temperature sensor. See [Ordering information](#) for available A99 Series sensor models.

You can extend the sensor leads in the field. See Table 1 for wire sizes and lengths. On long sensor cable runs, use shielded cable to reduce electromagnetic interference (EMI). Observe EMI best practices when you route sensor leads.

Do not immerse the A99 Series sensors in water or any other liquid. The A99 sensors are moisture tolerant and splash resistant but if you immerse the sensor, liquid can enter the sensor probe where the steel tube meets the wire cable and result in sensor failure, which voids any warranty.

In applications where the sensor may be exposed to a lot of moisture, splashing, or rain, it is best practice to mount the sensor in a vertical position with the cable at the bottom routed downward so that moisture can drain away from the steel probe. Use a suitable bulb well for complete fluid immersion applications. See [Ordering information](#) for information about bulb wells.

The A99 Series sensors are positive temperature coefficient (PTC) sensors. To test an A99 sensor, disconnect the sensor from the control and measure the resistance between the sensor leads in the following situations:

- When the temperature at the sensor is 77°F (25°C), the resistance should be 1,035 ohms.
- When the temperature at the sensor is 32°F (0°C), the resistance should be 855 ohms.

See [Troubleshooting](#) for more information.

When you connect an A99 sensor to a standard A421 Control, the control restricts the range of usable values from -40°F to 212°F (-40°C to 100°C).

See [Wiring](#), [Technical specifications](#), and refer to the *A99B Series Temperature Sensors Product/ Technical Bulletin (LIT-125186)* for more information about A99 Series sensors.

Mounting

Observe the following guidelines when you locate and mount an A421 Control:

- Make sure that the mounting surface can support the control, DIN rail, mounting hardware, and any user-supplied panel or enclosure.
- Mount the control in a vertical, upright orientation wherever possible. It is best practice to use DIN rail mounting for type 1 controls.
- In direct-mount applications, mount the control on a flat and even surface.
- Mount the control in a location free of corrosive vapors and observe the ambient operating conditions listed in [Technical specifications](#) for the A421 Control and the A99 sensor.
- Allow sufficient space to connect and route wires, view the LCD, and use the touchpad.

- Do not mount the control on surfaces that are prone to vibration or in a location where high-voltage relays, motor starters, other sources of electromagnetic emissions, or strong radio frequency may cause interference.
- Do not install the control in an airtight enclosure.
- Do not install heat generating devices with the control in an enclosure that may cause the ambient temperature to exceed 150°F (66°C).

Mounting a Type 1/IP20 control on DIN rail

1. Provide a section of 35 mm DIN rail that is longer than the control width. Mount the DIN rail in a suitable location and use appropriate mounting hardware.
2. Clip the control module on the rail, position the module's upper DIN rail clips on the top rail, and gently snap the lower clips on to the bottom of the rail.

Direct-mounting a Type 1/IP20 control to a wall or other flat surface using the four keyhole slots

1. Disconnect the power and remove the enclosure cover. Place the control horizontally against the wall surface in a suitable location, and mark the keyhole slot locations on the mounting surface.
2. Install appropriate screws or fasteners and leave the screw heads approximately one or two turns away from flush to the mounting surface.
3. Position the control mounting slots over the screw heads, and then tighten the mounting screws to secure the control to the surface.
 - ⓘ **Note:** When you mount the control on an uneven surface, use shims to mount the control evenly.

Additional guidelines for mounting Type 4X/IP66 controls

You can mount the Type 4X models to flat vertical surfaces using the four holes at the enclosure corners. Place the control against a flat wall surface in a suitable location, and mark the mounting screw hole locations on the mounting surface. Use appropriate screws and shims to mount the control evenly on the surface.

On Type 4X models, select the knockout for removal. Place a screwdriver blade on the knockout near the edge. Apply a sharp blow to the screwdriver handle to loosen the knockout. Be careful not to damage the control's interior components.

The A421 Control's temperature setback (BI) function requires an additional low-voltage, two-wire cable for operation. On Type 4X/IP66 enclosures, you must install a suitable watertight fitting in an available knockout to pass the two-wire cable through the enclosure wall.

You can rotate the control enclosure base on the Type 4X/IP66 models 180° relative to the control enclosure cover and LCD, to bring the electrical connection to the top or bottom of the mounted control.

- ⓘ **Note:** Do not twist the wiring harness between the enclosure base and cover more than 180°.

Wiring

Observe the following guidelines.

WARNING

Risk of Electric Shock

Disconnect or isolate all power supplies before making electrical connections. More than one disconnection or isolation may be required to completely de-energize equipment. Contact with components carrying hazardous voltage can cause electric shock and may result in severe personal injury or death.

Avertissement

Risque de Décharge Électrique

Débrancher ou isoler toute alimentation avant de réaliser un raccordement électrique. Plusieurs isolations et débranchements sont peut-être nécessaires pour couper entièrement l'alimentation de l'équipement. Tout contact avec des composants porteurs de tensions dangereuses risque d'entraîner une décharge électrique et de provoquer des blessures graves, voire mortelles.

- **Important:** Use copper conductors only. Make all wiring in accordance with local, national, and regional regulations.
- **Important:** Do not exceed the A421 Control's electrical ratings. Exceeding the electrical ratings can result in permanent damage to the control and void any warranty.
- **Important:** Run all low-voltage wiring and cables separate from all high-voltage wiring. It is best practice to use shielded cable input (sensor) cables that are exposed to high electromagnetic or radio frequency noise.
- **Important:** Electrostatic discharge (ESD) can damage A421 Controls. Use proper electrostatic discharge precautions during installation and servicing to avoid damaging A421 Controls.
- **Important:** Do not connect supply power to the A421 Controls before checking all wire connections. Short circuits or improperly connected wires can result in damage to the modules and void any warranty.
- **Important:** When you connect an A99 sensor with a shielded cable to an A421 Control, connect the cable shield drain lead to the common (COM) terminal on the sensor and binary input terminal block (TB3). Do not connect the shield at any other point along the cable, and isolate and insulate the shield along the entire length of the sensor cable. If you connect a cable shield at more than one point, transient currents can flow through the sensor cable shield and cause erratic control operation.

Observe the wire size restrictions listed in Table 2 and the electrical ratings listed in [Technical specifications](#).

Observe the following guidelines, procedures, and illustrations when you wire an A421 Series control and A99 Series sensor.

- Select the appropriate A99 sensors for the ambient operating range that the A421 Control monitors and controls, as shown in Table 6. See [Technical specifications](#) for more information.

- Keep the sensor leads as short as possible in your application. The additional resistance in long sensor cables creates an offset between the actual temperature and the displayed temperature. See Table 1 when you extend sensor leads.
- A99 sensors are not polarity specific. You can connect either lead to the SEN or COM terminals.
- It is best practice to use 22 AWG, stranded, twisted-pair cable with a shield to extend sensor cable runs.

Table 1: Maximum sensor cable lengths and wire sizes

Wire gauge	Maximum sensor cable length ¹
16 AWG	500 ft (152 m)
18 AWG	300 ft (91 m)
20 AWG	200 ft (61 m)
22 AWG	125 ft (38 m)

¹ The maximum sensor cable lengths have less than 1°F (0.6°C) error between the temperature sensed at the A99 sensor and the temperature displayed on the LCD.

TB2 Terminal Block and SPDT relay output

The terminals LC, LNO, and LNC on the TB2 terminal block connect to an SPDT dry-contact relay in the A421 Control (Figure 3). The control does not provide any internal power to the TB2 terminals or relay contacts. The A421 Control energizes and de-energizes the relay to open and close the contacts based on the On/Off temperature values.

- Relay De-energized (Off) = LC open to LNO as shown in Figure 3, and the relay status LED is off
- Relay Energized (On) = LC closed to LNO and the relay status LED is on

Figure 4 shows how to wire the A421 Control to use the same power source that powers the controlled equipment to also power the A421 Control.

Figure 3: TB2 Terminal Block showing connections to the internal SPDT relay

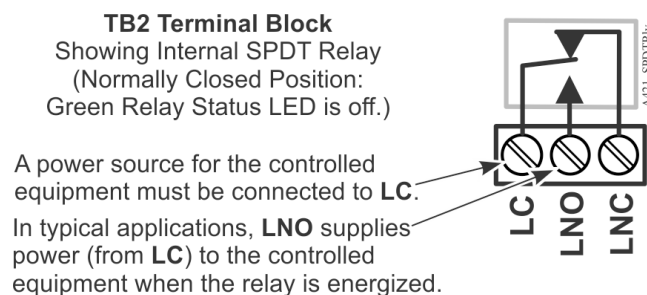

You can also provide an independent power source for the A421 Control on the TB1 terminals and then wire the TB2 relay terminals to a separate power source to switch and power the controlled equipment circuit.

Figure 4: Wiring the A421 Series Controls using the same power source to power the control operation and power the controlled equipment

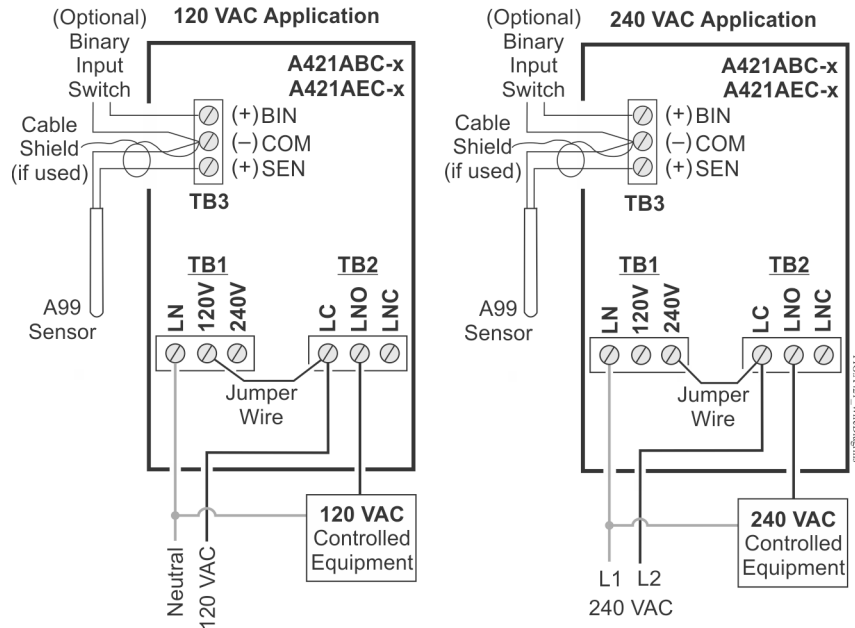

Table 2: A421 Control wiring terminals and wire size information

Terminal block	Label	Description, function, and requirements	Wire sizes
TB1 120/240 VAC Models	LN	Line-voltage power source (common): Connect the neutral wire for 120 VAC supply power applications. Connect the L1 supply power lead for all 208/240 VAC supply power applications.	28 AWG to 12 AWG 0.08 mm ² to 4.0 mm ²
	120 V	Line-voltage 120 VAC control power (hot): Connect the 120 VAC supply power (hot) for 120 VAC supply power applications (via jumper from LC in Figure 4).	
	240 V	Line-voltage 240 VAC control power (L2) terminal: Connect the L2 supply power connection for 208/240 VAC supply power applications through the jumper from LC. (Figure 4).	
TB2	LC	Line-voltage SPDT relay common contact: Connect power supply to power the controlled load. Connect 120 VAC (hot) for 120 VAC applications and L2 for 208/240 VAC applications.	28 AWG to 12 AWG 0.08 mm ² to 4.0 mm ²
	LNO	Line-voltage SPDT relay normally open contact: Connects controlled equipment to the line-voltage normally open (LNO) contact on the SPDT relay. When LC is closed to LNO, the relay is energized and the green LED is on. The LNO terminal typically provides power to the controlled equipment in cooling and heating applications.	4.0 mm ²

Table 2: A421 Control wiring terminals and wire size information

Terminal block	Label	Description, function, and requirements	Wire sizes
	LNC	Line-voltage SPDT relay normally closed contact: Connects controlled equipment to the line-voltage normally closed (LNC) contact on the SPDT relay. When LC is closed to LNC, the relay is de-energized and the green LED is off. The LNC terminal is not typically wired to the controlled equipment.	
TB3	BIN	Detects a switch closure between the BIN and COM terminals and manually starts or stops a defrost cycle. This is now the default behavior for the binary input.	22 AWG (0.34 mm ²) stranded, shielded cable
	COM	Connects the low-voltage common from the sensor and binary input.	
	SEN	Connects the low-voltage input signal wire from control sensors.	

Setup and adjustments

The front panel of the A421 Series Electronic Temperature Control has an LCD and a three-button UI as shown in the following figure.

Figure 5: A421 Control front panel with LCD and three-button UI

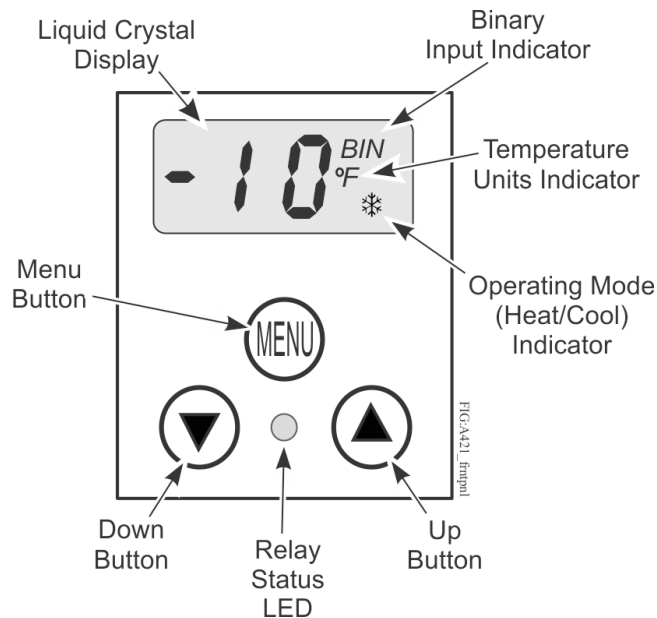

LCD

The A421 Series Control has a backlit LCD screen (Figure 5). You can adjust the LCD brightness. During normal operation, the LCD displays the Main screen, which provides the following information:

- Temperature sensed at the A99 sensor

- Selected temperature units (°F or °C)
- Mode of operation (Flame = Heating mode, Snowflake = Cooling mode)
- Binary Input status (BIN) when a user-supplied momentary switch is connected and closed to manually start or stop a defrost cycle.

During setup and adjustment, the LCD displays the parameter code screens and the parameter value screens. See the [A421 Control parameter setup menus](#) for more information.

Three-button touchpad

The touchpad has three buttons for setup and adjustment of the A421 Control (Figure 5). See [Navigating the Basic and Advanced menus](#) for more information about the three-button touchpad.

Relay status LED

The green LED on the front panel illuminates when the SPDT output relay is energized and the LC and LNO contacts are closed. See Figure 5.

Parameter codes and modes of operation

Relay Off temperature (OFF)

Select the temperature at which the output relay de-energizes, the LC to LNO relay contacts open (cutout), and the green LED goes off. The range of usable temperature values is -40°F to 212°F (-40°C to 100°C) in 1° increments.

Relay On temperature (On)

Select the temperature at which the output relay energizes, the LC to LNO relay contacts close (cut in), and the green LED lights. The range of usable temperature values is -40°F to 212°F (-40°C to 100°C) in 1° increments.

Heating or Cooling mode of operation

When you select your required On and OFF values, the control automatically determines the mode of operation and displays the proper mode icon on the Main screen.

- ① **Note:** The A421 Series Controls do not have jumpers for setting up the heating or cooling mode.

The heating or cooling mode is determined by the On and OFF value relationship as follows:

- **OFF > On** = Heating mode = Flame icon
- **OFF < On** = Cooling mode = Snowflake icon
- **Important:** During normal operation, adjusting just the On value or just the OFF value on the A421 Control changes the differential between On and OFF, and can potentially change the mode of operation from heating to cooling or cooling to heating. To maintain a constant differential between on and off, you must adjust both the On and OFF values by an equal number of degrees, or set up the control in the Restricted Adjustment mode. See [Restricting user adjustment](#).

Anti-Short Cycle Delay (ASd)

Select the minimum time that the output relay remains off (de-energized) before the next on-cycle can start. The ASd interval overrides any load demand (On) and does not allow the output relay to go on until the selected ASd interval has elapsed. See the following figure.

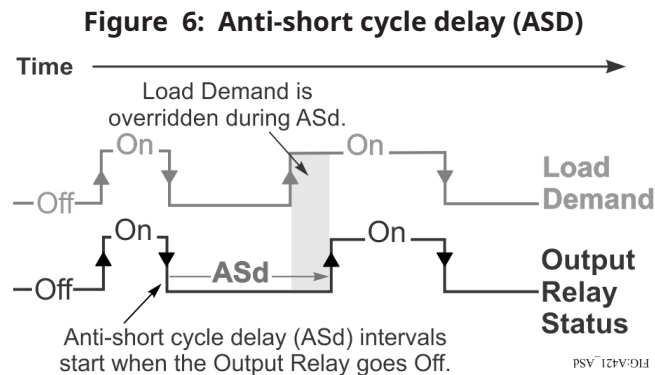

Anti-short cycle delay is typically used for refrigeration applications so that the system pressure can equalize before restarting the compressor.

- ① **Note:** When the ASd value is greater than 0, the delay interval initiates every time that the A421 Control powers on and every time that an off-cycle begins. When the ASd interval is activated, the temperature sensed at the A99 sensor and the parameter code ASd flash alternately on the LCD. You can set the ASd interval from 0 minutes to 12 minutes, in 1 minute increments.

Sensor Failure mode (SF)

Select whether the control's output relay operates as energized or de-energized in the event of a sensor or sensor wiring failure. When the control detects a sensor circuit failure, the output relay operates in the selected sensor failure mode. The LCD flashes SF and OP if the sensor circuit is open or SF and SH if the sensor circuit is shorted.

Temperature Units (Un)

Select the preferred temperature scale for your application. Select either the Fahrenheit (°F) or Celsius (°C) temperature scale.

- ① **Note:** After you change the temperature units value (Un), confirm that the temperature values for the other parameter codes are still correct for your application.

Low Temperature Stop (LtS)

Select the lowest temperature value that the On/OFF control band can be adjusted to when control adjustment is restricted.

High Temperature Stop (HtS)

Select the highest temperature value that the On/OFF control band can be adjusted to when control adjustment is restricted.

Restricted Adjustment mode

The HtS and LtS values define the restricted adjustment temperature range and are enforced only when the A421 Control is set to the restricted adjustment mode (Figure 12). See [Restricting user adjustment](#).

- ① **Note:** It is best practice to leave HtS and LtS at their default values, unless you intend to use the restricted adjustment mode.
- ① **Note:** If you use the Temperature Setback feature in the Restricted Adjustment mode, the effective On and OFF setback values (On + tBs and OFF + tBs) can be greater than the selected HtS value or less than the selected LtS value.

Temperature Setback (tSb)

Select a temperature value for setting back the On and OFF temperature values. When a user-supplied switch between the BIN and COM terminals closes, note the following changes:

- The Main screen displays BIN in the upper-right corner of the LCD.
 - The temperature setback feature is enabled and the control uses the effective On and OFF setback values (On + tSb and OFF + tSb) to control the relay.
- ① **Note:** The control displays only the original On and OFF values in the normal and setback modes. The effective setback On and OFF values (On + tSb and OFF + tSb) never display on the control LCD.

The temperature setback adjustment range is from -50°F to 50°F (-30°C to 30°C). Typically, heating applications require a negative temperature setback (tSb) value, and cooling applications require a positive value.

Sensor Offset Adjustment (So)

Sensor offset allows you to compensate for any difference between the displayed temperature value and the temperature sensed at the A99 sensor. Select a temperature value to offset the temperature displayed on the LCD from the temperature sensed at the sensor. The sensor offset adjustment range is from -5°F to 5°F (-3°C to 3°C) in 1° increments.

Backlight Brightness Level (bLL)

The backlight brightness level feature allows you to adjust the LCD backlight intensity. At level 0 the backlight is off. Level 10 is the brightest backlight setting and the system default. The selected backlight brightness level is applied to the LCD during normal operation. When you enter the programming menus to set up the control or press any key, the LCD automatically goes to the brightest level. If you do not press a key for 30 seconds, the main screen displays and the backlight setting reverts to the selected brightness level.

Defrost Cycle Time (dFt)

Select the time in minutes that the defrost cycle overrides On and keeps the relay Off. The dFt value can be between 1 minutes and 99 minutes. When the defrost cycle is On, the control is NOT running and the LCD displays the following screens: dEF (defrost mode), minutes remaining, and the temperature at the sensor. When the dFt is complete, the control returns to normal (On/Off cycle) operation.

Defrost Interval (dI)

Select the time in hours between the start of a defrost cycle and the next defrost cycle. The dI value can be set to 0 or 2 hours to 24 hours.

- ① **Note:** At the initial power On, the defrost interval (dI) does NOT have a defrost cycle (dFt). The subsequent defrost intervals begin with the selected dFt.

Setting the dI value to 0 eliminates regular or timed defrost cycles. You can still start or stop a defrost cycle by setting the SdF parameter or by using the binary input.

Start or Stop Defrost Cycle (SdF)

The Start/Stop Defrost Cycle parameter allows you to start a defrost cycle, when the control is in normal (On/Off cycle) operation, or stop a defrost cycle when the defrost cycle is On.

Change to the SdF value to 1 to start a defrost cycle. Or, change the value to 0 to stop the defrost cycle, and return to normal (On/Off cycle) operation.

Binary Input modes (bIn)

The BIN mode allows you to select how the A421 Control operates when a user-supplied binary switch connected across BIN and COM on the TB3 terminal block is used with the control.

Set the BIN parameter to 0 to use the temperature setback feature. Set the value to 1 and connect a user-supplied momentary contact switch to start or stop a defrost cycle.

Table 3: Standard parameter setup codes, descriptions, range of values, and default values

Parameter code	Parameter description (menu)	Range of usable values	Factory default value ¹
Un	Temperature Units (Advanced only)	°F or °C	°F
OFF	Relay Off Temperature (Basic, Advanced, and Restricted)	-40°F to 212°F (-40°C to 100°C)	25°F
On	Relay On Temperature (Basic and Advanced)	-40°F to 212°F (-40°C to 100°C)	30°F
ASd	Anti-Short Cycle Delay (Basic and Advanced)	0 minutes to 12 minutes	1 minute
tSb	Temperature Setback (Advanced only)	-50°F to 50°F (-30°C to 30°C)	0°F
So	Sensor Offset Adjustment (Advanced only)	-5°F to 5°F (-3°C to 3°C)	0°F
HtS	High Temperature Stop (Advanced only)	-40°F to 212°F (-40°C to 100°C)	212°F
LtS	Low Temperature Stop (Advanced only)	-40°F to 212°F (-40°C to 100°C)	-40°F
SF	Sensor Failure Action (Basic and Advanced)	0 = output relay de-energized 1 = output relay energized	1 output relay energized
bLL	LCD Backlight Brightness Level Adjustment (Advanced only)	0 to 10; 0 = backlight off, 10 = brightest backlight setting	10 (brightest backlight)
dFt	Defrost Cycle Time (Advanced only)	1 minutes to 99 minutes	30 minutes
dI	Defrost Interval (Advanced only)	0 or 2 hours to 24 hours	8 hours

Table 3: Standard parameter setup codes, descriptions, range of values, and default values

Parameter code	Parameter description (menu)	Range of usable values	Factory default value ¹
SdF	Start or Stop Defrost Off-Cycle (Advanced only)	Change 0 to 1 to Start a new Defrost Cycle Change 1 to 0 to Stop a Defrost Cycle	0
bIn	Binary Input Mode (Advanced only)	0 = Temperature Setback Mode 1 = Start Defrost Cycle Mode	1

¹ The default values for general application A421 models are shown. OEM A421 models may have different default values.

A421 Control parameter setup menus

The A421 Temperature Controls have a Basic and an Advanced setup menu. You can use these menus to scroll through the parameter setup codes, view and edit parameter values, and set up your control for your application requirement. The control also has a Restricted adjustment menu. See [Restricting user adjustment](#) for more information.

- ① **Note:** The A421 Control retains a copy of the saved parameter values in memory. When you change and save a new value, the new value immediately overwrites the previous value and saves to memory. In the event of a power failure, brown out, or when you disconnect power from the control, all of the current parameter values in memory are retained. Reconnecting power to the control restores all of the saved values.

Navigating the Basic and Advanced menus

The A421 Control buttons and display operate the same way in the Basic and Advanced menus. You can perform the following actions in any parameter code screen:

The parameter code flashes on and off.

- To navigate through all of the parameter code screens, press **Down** or **Up**.
- To exit either menu and return to the Main screen, press **Down** and **Up** simultaneously.

You can perform the following actions in any parameter code screen:

The parameter value flashes on and off.

- To scroll through all of the available parameter values for the associated parameter code, press **Down** or **Up**.
- With the preferred parameter value displayed, press **MENU** to save the value and go to the next parameter code screen.

- ① **Note:** If you do not press **MENU** to save a new value, the control reverts to the last saved value.

After 30 seconds of inactivity while in any screen, the control reverts to the Main screen.

Basic menu

Use the Basic menu to quickly edit the On and OFF temperature values, as well as the Sensor Failure Mode (SF) and the Anti-Short Cycle Delay (ASd) value.

See [Parameter codes and modes of operation](#) and Table 3 for more information about parameter codes, usable parameter values, and default values.

Figure 7: Navigating the Basic menu

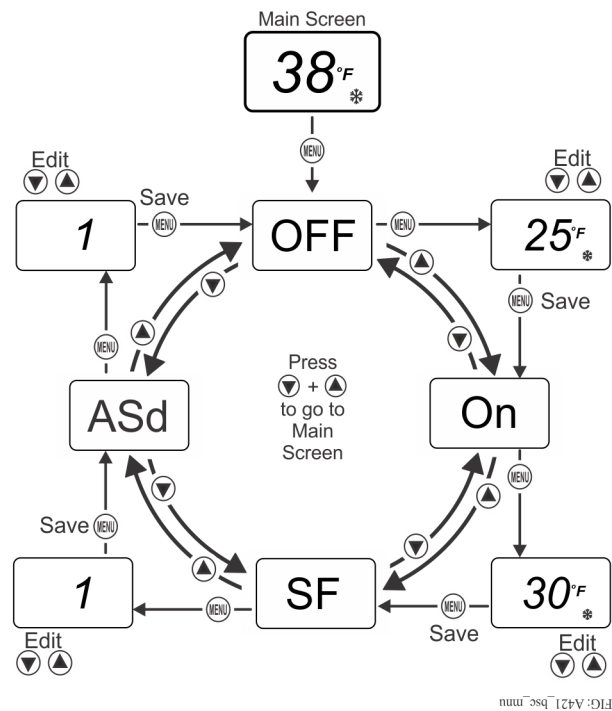

Viewing and changing values in the Basic menu

To access the Basic menu and view and change the Basic parameter values, complete the following steps:

1. On the Main screen, press **MENU**. The LCD displays OFF, which is the first parameter code screen displayed in the Basic menu.
2. To scroll through all of the basic parameter codes and display the preferred code, press **Down** or **Up**.
3. With the preferred parameter code displayed, press **MENU** to display the current parameter value for the code.
4. With the current parameter value displayed, press **Down** or **Up** to scroll through all of the parameter's usable values and display the preferred value.
5. With the preferred parameter value displayed, press **MENU** to save the displayed value and go to the next parameter code.

To exit the Basic menu and go to the Advanced menu, simultaneously press and hold **Down** and **Up**, for 5 seconds.

Advanced menu

You can use the Advanced menu to change the parameter values in the Basic menu and the parameter values for the following advanced parameter codes:

- Temperature Units (**Un**)
- Low Temperature Setpoint Stop (**LtS**)
- High Temperature Setpoint Stop (**HtS**)
- Anti-Short Cycle Delay (**ASd**)
- Defrost Cycle Time (**dFt**)
- Defrost Interval (**dI**)
- Binary Input Mode (**bLn**)
- Backlight Brightness Level (**bLL**)
- Temperature Setback (**tSb**)
- Sensor Offset (**So**)
- Sensor Failure Option (**SO**)
- Start or Stop Defrost Cycle (**SdF**)

See [Parameter codes and modes of operation](#) and Table 3 for more information about parameter codes, usable parameter values, and default values.

Figure 8: Navigating the Advanced menu

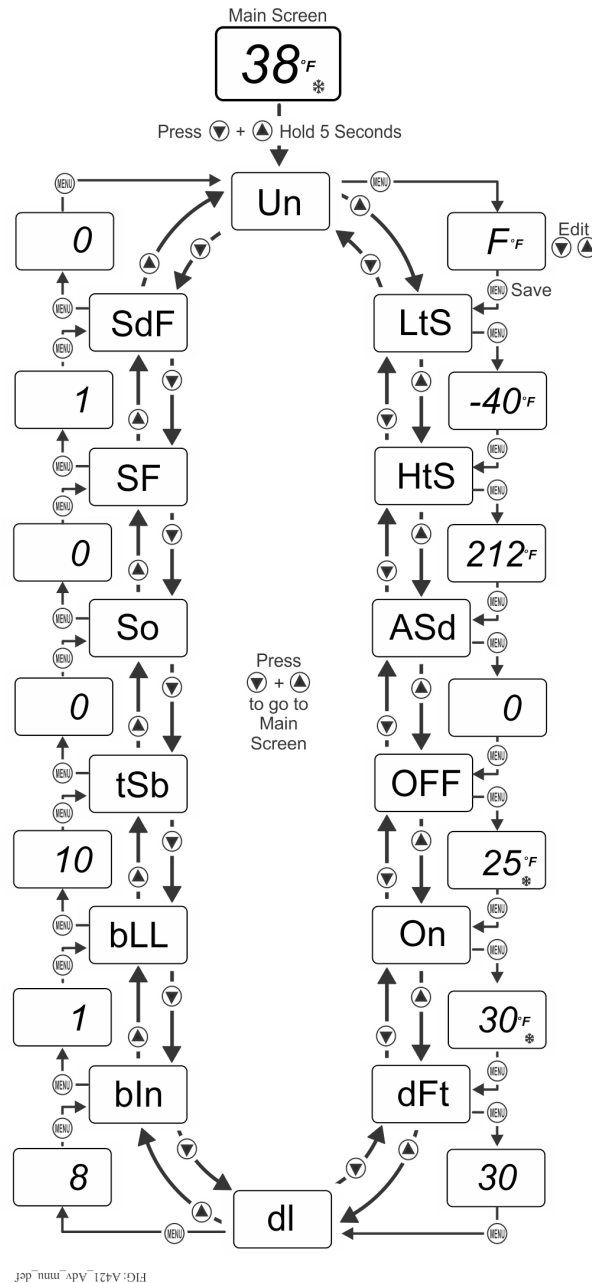

Viewing and changing values in the Advanced menu

To access the Advanced menu and view and change the parameter values, complete the following steps:

1. On the Main screen, press and hold **Down** and **Up** simultaneously for 5 seconds. Un displays on the LCD, which is the first parameter code screen displayed in the Advanced menu.
2. To scroll through all of the advanced parameter codes and display the preferred code, press **Down** or **Up**.
3. With the preferred parameter code displayed, press **MENU** to display the current parameter

value for the code.

4. With the current parameter value displayed, press **Down** or **Up** to scroll through all of the parameter code's usable values and display the preferred value.
5. With the preferred parameter value displayed, press **MENU** to save the displayed value and go to the next parameter code.

Setting up a regular or timed Defrost Off-Cycle

The controller enforces the following behavior:

- At power up, the initial Defrost Interval (dI) does not have a Defrost Cycle (dFt).
- Subsequent defrost intervals (dI) begin with the selected dFt value.
- All defrost intervals have the same length.

To set up a regular or timed defrost cycle:

1. Select a dI value between 2 hours and 24 hours.
i Note: A dI value of 0 indicates no defrost interval.
2. Select a dFt value between 1 minute and 99 minutes. See Figure 9.

Figure 9: Typical passive Defrost Cycle behavior

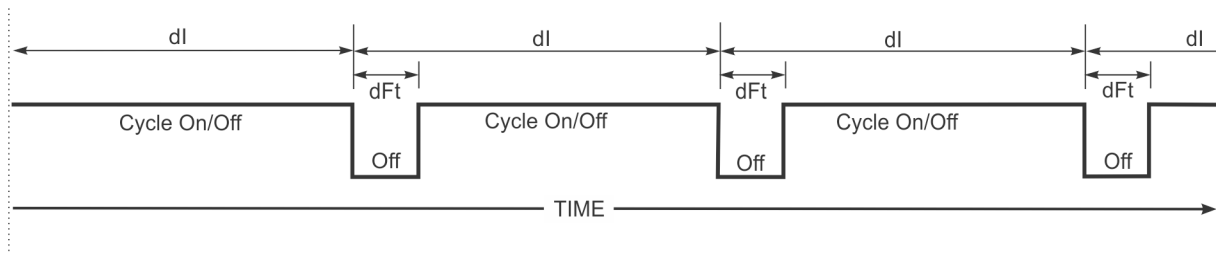

Control behavior when manually starting or stopping a Defrost Off-Cycle

The controller enforces the following behavior:

- Manually start a Defrost Cycle. The control returns to normal On/Off operation after the defrost cycle time (dFt) is complete.
- Manually stop a Defrost Cycle. The defrost cycle time (dFt) is terminated and the control is returned to normal On/Off operation.

Manually starting and stopping a Defrost Cycle (SdF)

To manually Start/Stop a Defrost Cycle (SdF):

1. Select a Defrost Interval (dI) value of 0.
2. Select a dFt value between 1 minute and 99 minutes.
3. - Select an SdF parameter value of 1 during normal On/Off operation to start a defrost cycle.

- Or, change the SdF value to 0 during a defrost cycle and return to normal On/Off operation. See the figure below.

Figure 10: Manual Defrost only: behavior when dI is set to 0

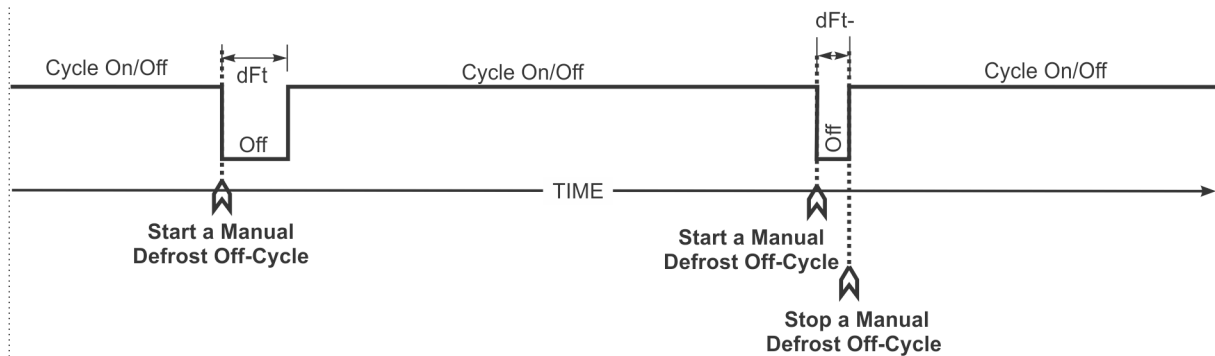

Control behavior when starting or stopping an automatically enabled Defrost Off-Cycle

The controller enforces the following behavior:

- At power up, the initial Defrost Interval (dI) does not initiate a Defrost Cycle Time (dFt).
- A defrost cycle occurs at the beginning of each subsequent defrost interval.
- You can start or stop a defrost cycle using the SdF parameter or binary input (BIN).
- Starting a defrost cycle terminates the defrost interval (dI) and starts a new defrost cycle.
- Stopping a defrost cycle terminates the dFt and continues the current defrost interval (dI) until the start of the next regular dI and defrost cycle.

Starting or stopping a Defrost Cycle using the SdF parameter

- To start or stop a Defrost Cycle using the SdF parameter:
 - Select a Start/Stop Defrost Cycle (SdF) parameter value of 1.
 - Or, change the SdF value to 0 (zero) during a dFt to stop a defrost cycle and return the control to normal On/Off operation. See Figure 11.

Starting or stopping a Defrost Cycle using the binary input (BIN)

- To start or stop a Defrost Cycle using the Binary Input (BIN):
 - Connect a momentary contact switch between BIN and COM on the T3 terminal block.
 - Each time the momentary contact switch is pressed, the defrost cycle starts or stops depending on whether the defrost cycle is running or not. See Figure 11.

Figure 11: Starting and stopping a dFT: behavior using SdF parameter and momentary contact switch

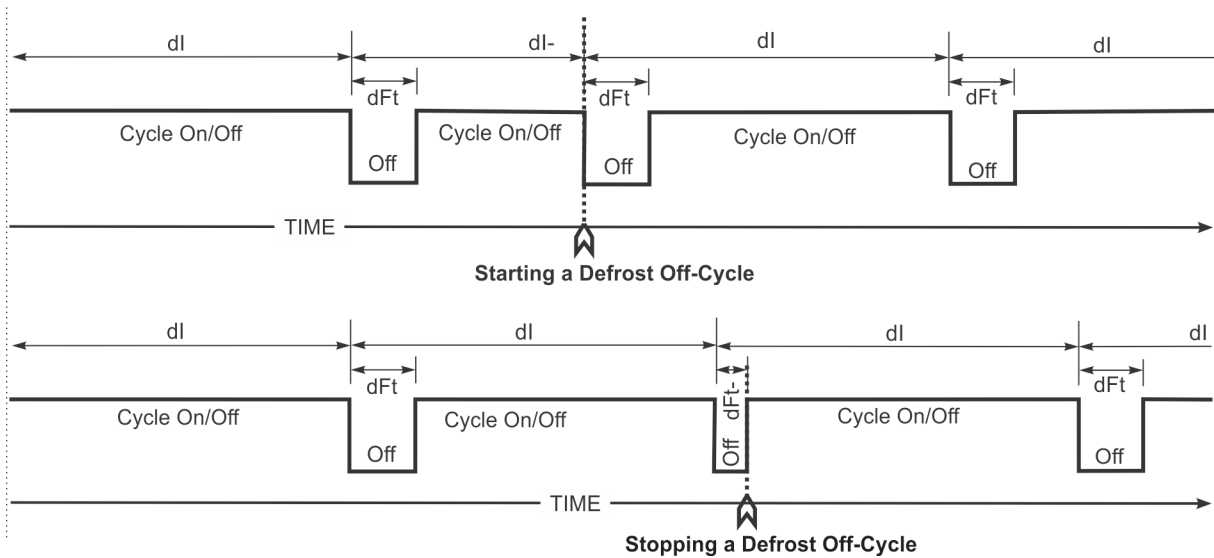

Restricting user adjustment

You can restrict user adjustment of the A421 Control to the OFF value control band adjustment within a defined range (Figure 12) or no user adjustment at all.

To set the A421 Control to the restricted adjustment mode, position the P1 jumper located on the circuit board next to the TB3 terminal block. See [Setting the control to Restricted Adjustment mode](#).

- ① **Note:** Setting the A421 Control up in the Restricted mode prevents casual users from over-adjusting the control in your application, or from inadvertently changing the mode of operation from cooling to heating or heating to cooling (by over-adjusting the On value or OFF value).

When the A421 Control is set up in the restricted adjustment mode, the controller enforces the following behavior:

- The selected HtS and LtS values define the restricted temperature adjustment range..
- The On and OFF values define the control band differential, and the control band between On and OFF remains fixed and not adjustable.
- Only the OFF value can be adjusted, the control band remains fixed, and the On value automatically shifts equal to the OFF value adjustment.
- The OFF value can only be adjusted to values that maintain the entire control band within the restricted temperature adjustment range defined by HtS and LtS. See Figure 12.
- The basic and advanced menus are not available. Only the Restricted Adjustment mode menu is available and only the OFF value can be adjusted. See Figure 14.

Figure 12: Adjustment behavior in Restricted Adjustment mode

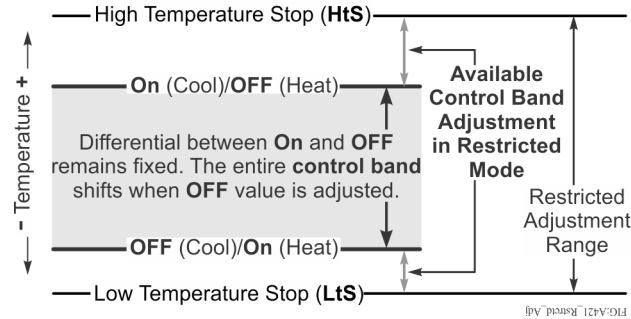

Setting the control to Restricted Adjustment mode

To set up the restricted adjustment feature, complete the following steps:

1. To make sure that the A421 is not in restricted mode, position the jumper on both pins. See Figure 13.
2. Select the OFF and On values that define the application’s required control band (Figure 12).
3. Change the HtS and LtS temperature values to define the restricted adjustment range (Figure 12).
4. Disconnect power to the control and reposition the jumper to one pin (Figure 13). Reconnect the power.

Figure 13: Repositioning the jumper to restrict control adjustment

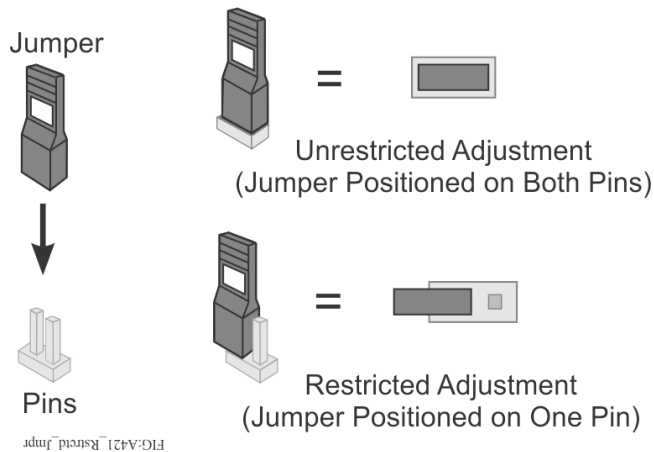

Control adjustment is now restricted to changing only the OFF value, which shifts the On and OFF control band within the restricted adjustment range defined by HtS and LtS (Figure 12).

- ① **Note:** To completely restrict and lockout all user adjustment on the control, set the HtS value equal to the On or OFF value and the LtS value equal to the OFF or On value. Then the (On to OFF) control band is equal to the restricted adjustment range, LtS to HtS, and the OFF value cannot be adjusted in the restricted mode.

Adjusting the control in Restricted mode

To adjust the OFF value and shift the On and OFF control band within the restricted adjustment range, when the control is in the restricted adjustment mode, complete the following steps:

1. On the Main Screen, press **MENU** to go to the Restricted Adjustment mode menu and display the OFF parameter code screen (Figure 14).
2. To go to the OFF value screen, press **MENU** again.
3. On the OFF value screen, press **Down** or **Up** to change the **OFF** value within the restricted adjustment range only.
4. To save the selected **OFF** value and return to the **OFF** code screen, press **MENU**.
5. To return to the Main screen, press **Down** and **Up** simultaneously.

Figure 14: Adjusting temperature in the Restricted menu

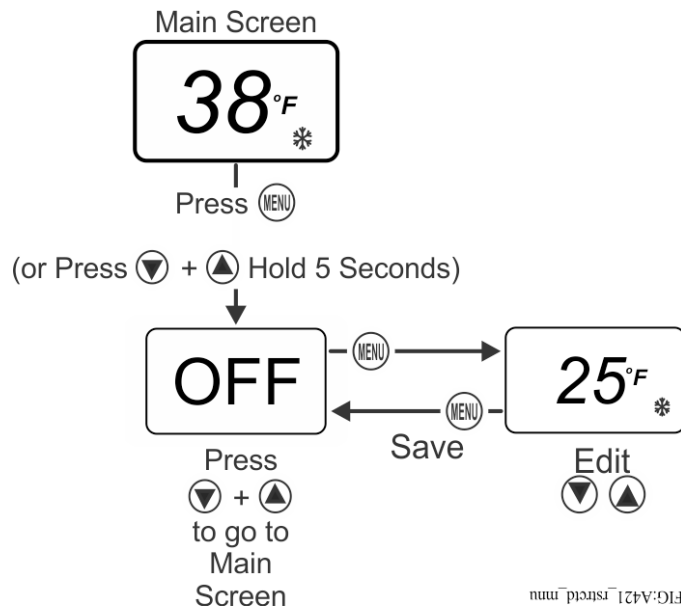

Troubleshooting

A421 Series Controls display fault codes on the LCD as described in Table 4.

Table 4: Fault codes

Fault code	Definition	System status	Solution
SF flashing alternately with OP	Open temperature sensor or sensor wiring	Output functions according to the selected SF mode	See Troubleshooting procedure . Cycle power to reset the control.
SF flashing alternately with SH	Shorted temperature sensor or sensor wiring	Output functions according to the selected SF mode	See Troubleshooting procedure . Cycle power to reset the control.

Table 4: Fault codes

Fault code	Definition	System status	Solution
EE	Program failure	Output is off	To reset the control, press MENU . If problems persist, replace the control.

Troubleshooting procedure

1. Check for proper voltage to the A421 Control.
 - a. To remove the cover, loosen the two captive cover screws.
 - b. Use an AC voltmeter to check the voltage between the COM and 120 V or 240 V terminals on line-voltage models. See Figure 4.
The voltage must be between:
 - 102 VAC and 132 VAC for 120 VAC applications
 - 177 VAC and 264 VAC for 208/240 VAC applications
 - c. If the voltage reading is not within the required range, check the power source and input power wires for problems.
2. Check for proper sensor operation.
 - a. Disconnect all power sources to the control.
 - b. Use an accurate thermometer to take a temperature reading at the sensor location.
 - c. Disconnect the sensor from the control.
 - d. Use an ohmmeter to measure the resistance across the two sensor leads while the sensor is at the temperature taken in Step 2b.
 - e. See Figure 15 to verify that the measured temperature and resistance conform to established temperature and resistance values.
 - f. If the measured values conform to the values in Figure 15, proceed to Step 3.
 - g. If the sensor's measured resistance value is substantially different from the expected value for that temperature, check the sensor wiring. If sensor wiring is correct, replace the sensor.

Figure 15: Temperature versus sensor resistance

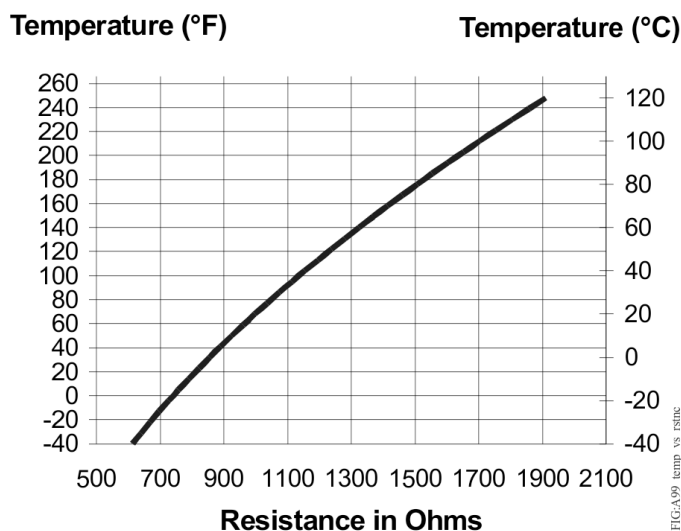

3. Check the A421 for proper operation.
 - ⓘ **Note:** Perform troubleshooting Steps 1 and 2 before you perform this step.
 - a. Disconnect the load from the output relay terminals.
 - b. Make sure that you install the Parameter Adjustments jumper so that you have unrestricted access to adjust parameters.
 - c. Reconnect the sensor leads and supply power to the control.
 - d. Replace the cover.
 - e. Check the control settings for proper values.
 - f. Press **MENU** until **On** appears. Press **MENU** again to display the On value.
 - g. Press **Down** or **Up** to change the On temperature above and below the sensor temperature until the relay energizes and de-energizes.
 - ⓘ **Note:** If the anti-short cycle delay is set to a value other than 0 minutes, when the control is powered On, on the relay does not energize until the time delay elapses.
 - h. If the output relay does not perform as expected, replace the A421 Control.
 - i. If you verify proper operation of the A421 Control, reconnect the load and consult the equipment manufacturer's instructions to troubleshoot the controlled equipment.

Repair information

Do not attempt to repair or recalibrate the A421 Temperature Control. In case of a defective or improperly functioning control, contact your nearest authorized Johnson Controls/PENN distributor or sales representative.

When you contact your Johnson Controls/PENN distributor, have the model number of the control available. You can find this number on the label inside the cover of the control.

Ordering information

See Table 5 to order a standard A421 Series Electronic Temperature Control. See Table 6 and Table 7 for more information about A99 sensors, mounting hardware, and other accessories used to install A421 Controls. Contact your nearest Johnson Controls or PENN distributor or sales representative to order these products.

Table 5: A421 Series Electronic Temperature Controls with Off-Cycle Defrost Timer selection chart

Product type	Description
A421ABD-02C	Line-voltage Type 1 Electronic Temperature Control with Off-Cycle Defrost Timer: Type 1 (NEMA), IP20 standard enclosure for DIN rail and surface-mount applications. Rated for 120/240 VAC. Includes timer for On/Off defrost cycle control. Includes an A99BB-200C temperature sensor with 6.6 ft (2.0 m) cable.
A421AED-01C	Line-voltage Type 4X Electronic Temperature Control with Off-Cycle Defrost Timer: Type 4X (NEMA), IP66 watertight enclosure for surface-mount applications. Rated for 120/240 VAC. Includes timer for On/Off defrost cycle control. Includes an A99BB-25C temperature sensor with 9 7/8 in. (0.25 m) cable.
A421AED-02C	Line-voltage Type 4X Electronic Temperature Control with Off-Cycle Defrost Timer: Type 4X (NEMA), IP66 watertight enclosure for surface-mount applications. Rated for 120/240 VAC. Includes timer for On/Off defrost cycle control. Includes an A99BB-200C temperature sensor with 6.6 ft (2.0 m) cable.

Table 6: A99 Temperature Sensors selection chart¹

Product code	Description
A99BA-200C	Positive temperature coefficient (PTC) Temperature Sensor: Standard probe 2 in. (5.1 cm) with 6.6 ft (2.0 m) shielded polyvinyl chloride (PVC) cable; ambient operating temperature range: -40°F to 212°F (-40°C to 100°C)
A99BB-25C	PTC Temperature Sensor: Standard probe 2 in. (5.1 cm) with 9 7/8 in. (0.25 m) PVC cable; ambient operating temperature range: -40°F to 212°F (-40°C to 100°C)
A99BB-200C	PTC Temperature Sensor: Standard probe 2 in. (5.1 cm) with 6.6 ft (2.0 m) PVC cable; ambient operating temperature range: -40°F to 212°F (-40°C to 100°C)
A99BB-300C	PTC Temperature Sensor: Standard probe 2 in. (5.1 cm) with 9.8 ft (3.0 m) PVC cable; ambient operating temperature range: -40°F to 212°F (-40°C to 100°C)
A99BB-400C	PTC Temperature Sensor: Standard probe 2 in. (5.1 cm) with 13.1 ft (4.0 m) PVC cable; ambient operating temperature range: -40°F to 212°F (-40°C to 100°C)
A99BB-600C	PTC Temperature Sensor: Standard probe 2 in. (5.1 cm) with 19.7 ft (6.0 m) PVC cable; ambient operating temperature range: -40°F to 212°F (-40°C to 100°C)
A99BC-25C ¹	PTC Temperature Sensor: Standard probe 2 in. (5.1 cm) with 9 7/8 in. (0.25 m) high-temperature silicon cable; ambient operating temperature range: -40°F to 248°F (-40°C to 100°C)
A99BC-100C ¹	PTC Temperature Sensor: Standard probe 2 in. (5.1 cm) with 3.3 ft (1.0 m) high-temperature silicon cable; ambient operating temperature range: -40°F to 248°F (-40°C to 120°C)

Table 6: A99 Temperature Sensors selection chart¹

Product code	Description
A99BC-300C ¹	PTC Temperature Sensor: Standard probe 2 in. (5.1 cm) with 9.8 ft (3.0 m) high-temperature silicon cable; ambient operating temperature range: -40°F to 248°F (-40°C to 120°C)
A99BC-500C ¹	PTC Temperature Sensor: Standard probe 2 in. (5.1 cm) with 16.4 ft (5.0 m) high-temperature silicon cable; ambient operating temperature range: -40°F to 248°F (-40°C to 120°C)
A99BC-1500C ¹	PTC Temperature Sensor: Standard probe 2 in. (5.1 cm) with 49.2 ft (15.0 m) high-temperature silicon cable; ambient operating temperature range: -40°F to 248°F (-40°C to 120°C)
A99CB-200C	PTC Temperature Sensor: Extended probe 6 in. (15.2 cm) with 6.6 ft (2.0 m) PVC cable; ambient operating temperature range: -40°F to 212°F (-40°C to 100°C)
A99CB-600C	PTC Temperature Sensor: Extended probe 6 in. (15.2 cm) with 19.7 ft (6.0 m) PVC cable; ambient operating temperature range: -40°F to 212°F (-40°C to 100°C)

1 When any A99 Series Temperature Sensor is connected to a standard A421 Control model, the range of displayed temperature values is -40°F to 212°F or -40°C to 100°C.

Table 7: Accessories

Product code	Description
BKT287-1R	12 in. (305 mm) long DIN rail section
BKT287-2R	36 in. (914 mm) long DIN rail section
PLT344-1R	Two end clamps for DIN rail sections
A99-CLP-1	Surface mounting clip for A99B and A99C Series Temperature Sensors
SHL10-603R	Sun shield for A99B and A99C Series Temperature Sensors
BOX10A-603R	PVC enclosure for A99B and A99C Series Temperature Sensors
WEL11A-601R	Copper and brass immersion well for applying sensor in fluid applications
TE-6300W-102	Stainless steel immersion well for applying A99 sensors in fluid applications. A99CB Type sensors with extended probe with this immersion well.

Technical specifications

Table 8: A421 Series Electronic Temperature Controls

Power consumption	1.8 VA maximum
Supply power	110/120 VAC or 208/230/240 VAC, 50/60 Hz
Ambient conditions	Operating: Type 1 models: -40°F to 150°F (-40°C to 66°C), 0% to 95% RH noncondensing Type 4X models: -40°F to 140°F (-40°C to 60°C), 0 to 95% RH noncondensing Shipping and storage: All models: -40°F to 185°F (-40°C to 85°C), 0% to 95% RH noncondensing
Temperature control range	-40°F to 212°F or -40°C to 100°C

Table 8: A421 Series Electronic Temperature Controls

Input signal	1,035 ohm at 77°F (25°C) for A99 PTC Temperature Sensors
Accuracy	Combined accuracy of A421 Control and A99 sensor: ±2°F (±1°C) between 5°F and 167°F (-15°C and 75°C); diverging to ±3°F (±2°C) at -40°F (-40°C) and ±3°F (±2°C) at 212°F (100°C)
Sensor offset range	±5°F or ±3°C
Enclosure material	Type 1, IP20 high-impact thermoplastic or Type 4X, IP66 watertight, corrosion-resistant, high-impact thermoplastic
Compliance	<p>North America: cULus Listed; UL 60730, File E27734, Vol. 1; FCC Compliant to CFR47, Part 15, Subpart B, Class B Industry Canada (IC) Compliant to Canadian ICES-003, Class B limits</p> <p>Europe: CE Mark – Johnson Controls declares that this product is in compliance with the essential requirements and other relevant provisions of the EMC Directive; Low Voltage Directive.</p> <p>Australia and New Zealand: RCM, Australia/NZ Emissions Compliant</p>

**Table 9: A421 Temperature Control Output Relay Contacts electrical ratings**

Agency and file	UL 60730 and EN 60730		
Applied AC voltage at 50/60 Hz	120 VAC	208 VAC	240 VAC
Horsepower LC/LNO (LC/LNC)	1 (0.25)	1 (0.3)	1 (0.5)
Full load amperes LC/LNO (LC/LNC)	16 (5.8)	9.2 (4)	8 (4.9)
Locked rotor amperes LC/LNO (LC/LNC)	96 (34.8)	55.2 (24)	48 (29.4)
Resistive amperes LC/LNO (LC/LNC)	15 (10)	10 (10)	10 (10)
Pilot duty VA LC/LNO (LC/LNC)	125 (125)	125 (125)	125 (125)

Table 10: UL conformity declaration information

Information	Description
Purpose of control	Sensing control / operating control
Construction of control	Electronic independently mounted control
Number of cycles	30,000 cycles
Method of mounting control	Mounting screws or DIN rail
Type 1 or type 2 action	Type 1.B (Micro-disconnection)
External pollution situation	All models: A421 [] B: Pollution degree 3 All models: A421 [] E: Pollution degree 4
Internal pollution situation	Pollution degree 2
Heat and fire resistance category	D
Rated impulse voltage	4,000 V
Ball pressure temperature	128°C
Cover screw torque requirements instruction	All models: A421 [] E: To maintain type 4X / IP66 rating, tighten enclosure screws to 10-12 in·lb

Table 11: A99B Series Positive Temperature Coefficient Sensors

Sensing range ¹	Type A99BA and A99BB: -40°F to 212°F (-40°C to 100°C) Type A99BC: -40°F to 248°F (-40°C to 120°C)
Reference resistance	1,035 ohms at 77°F (25°C) and 855 ohms at 32°F (0°C)
Accuracy	0.9°F (0.5°C) between 5°F and 167°F (-15°C and 57°C). Refer to the <i>A99B Series Temperature Sensors Product/Technical Bulletin (LIT-125186)</i> for accuracy rating outside of this temperature range.
Sensor construction	Probe: Stainless steel
Sensor cable sheath	Type A99BA: Shielded PVC cable Type A99BB: PVC cable Type A99BC: High temperature silicon cable
Wire gauge	22 AWG
Ambient operating conditions	Type A99BA and A99BB: -40°F to 212°F (-40°C to 100°C); 0% to 100% RH, condensing Type A99BC: -40°F to 248°F (-40°C to 120°C); 0% to 100% RH, condensing
Ambient storage conditions	Type A99BA and A99BB: -40°F to 221°F (-40°C to 105°C); 0% to 100% RH, condensing Type A99BC: -40°F to 266°F (-40°C to 130°C); 0% to 100% RH, condensing
Shipping weight	1.4 oz (41 g) for 6 1/2 ft (2 m) sensor
Accessories	See Table 7

1 When any A99 Series Temperature Sensor is connected to a standard A421 Control model, the range of displayed temperature values is -40°F to 212°F or -40°C to 100°C.

The performance specifications are nominal and conform to acceptable industry standards. For application at conditions beyond these specifications Johnson Controls shall not be liable for damages resulting from misapplication or misuse of its products.

North American emissions compliance

United States

This equipment has been tested and found to comply with the limits for a Class B digital device, pursuant to Part 15 of the FCC Rules. These limits are designed to provide reasonable protection against harmful interference in a residential installation. This equipment generates, uses and can radiate radio frequency energy and, if not installed and used in accordance with the instructions, may cause harmful interference to radio communications. However, there is no guarantee that interference will not occur in a particular installation. If this equipment does cause harmful interference to radio or television reception, which can be determined by turning the equipment off and on, the user is encouraged to try to correct the interference by one or more of the following measures:

- Reorient or relocate the receiving antenna.
- Increase the separation between the equipment and receiver.
- Connect the equipment into an outlet on a circuit different from that to which the receiver is connected.
- Consult the dealer or an experienced radio or TV technician for help.

Canada

This Class (B) digital apparatus meets all the requirements of the Canadian Interference-Causing Equipment Regulations.

Cet appareil numérique de la Classe (B) respecte toutes les exigences du Règlement sur le matériel brouilleur du Canada.

Points of Single Contact

APAC	Europe	NA/SA
JOHNSON CONTROLS	JOHNSON CONTROLS	JOHNSON CONTROLS
C/O CONTROLS PRODUCT MANAGEMENT	WESTENDHOF 3	507 E MICHIGAN ST
NO. 32 CHANGJIJANG RD NEW DISTRICT	45143 ESSEN	MILWAUKEE WI 53202
WUXI JIANGSU PROVINCE 214028	GERMANY	USA
CHINA		